

Structure Elucidation of Depropylamino Chloro Propafenone-d5

Author: BenchChem Technical Support Team. **Date:** May 2026

Compound of Interest

Compound Name:	<i>Depropylamino Chloro Propafenone-d5</i>
CAS No.:	<i>1346598-65-9</i>
Cat. No.:	<i>B584960</i>

[Get Quote](#)

Technical Guide for Analytical & Medicinal Chemists Executive Summary & Chemical Identity

Depropylamino Chloro Propafenone (also known as Propafenone Chlorohydrin or EP Impurity E) is the penultimate intermediate in the synthesis of the antiarrhythmic drug Propafenone. The d5-labeled analog is engineered by incorporating a fully deuterated chlorohydrin linker, rendering it chemically identical to the impurity but distinguishable by mass spectrometry.

Target Molecule Profile

Feature	Details
Common Name	Depropylamino Chloro Propafenone-d5
Systematic Name	1-[2-(3-chloro-2-hydroxypropoxy-d5)phenyl]-3-phenylpropan-1-one
Parent Drug	Propafenone (Class 1C Antiarrhythmic)
Regulatory Status	Pharmacopeial Impurity (EP Impurity E)
Molecular Formula	C ₁₈ H ₁₄ D ₅ ClO ₃
Exact Mass	~323.13 (Monoisotopic, ³⁵ Cl)
Label Position	2-hydroxy-3-chloropropoxy linker (d5)

Structural Logic

The term "Depropylamino" indicates the absence of the N-propylamine moiety found in Propafenone. The "Chloro" designation confirms the presence of a terminal chloride, identifying this molecule as the chlorohydrin intermediate formed prior to amination.

Synthesis & Isotopic Origin

Understanding the synthetic origin is the first step in structural verification. The d5-label is introduced via Epichlorohydrin-d5, ensuring the label is located on the metabolically stable ether linker rather than the exchangeable aromatic protons.

Retro-Synthetic Pathway (DOT Visualization)

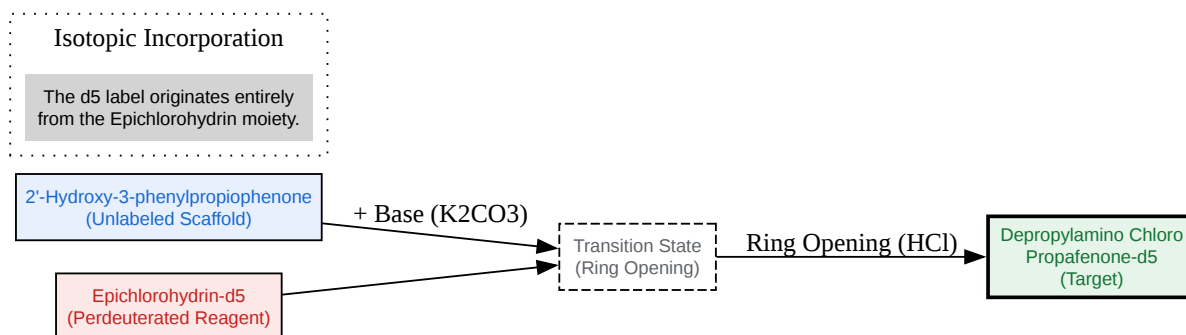

[Click to download full resolution via product page](#)

Figure 1: Synthetic pathway demonstrating the incorporation of the d5-label into the chlorohydrin linker.

Mass Spectrometry (HRMS) Elucidation

High-Resolution Mass Spectrometry (HRMS) provides the primary confirmation of the molecular formula and isotopic enrichment.

Isotopic Signature & Chlorine Pattern

The presence of Chlorine (³⁵Cl/³⁷Cl) creates a distinct isotopic envelope that must be deconvoluted from the deuterium (d5) shift.

- Theoretical Monoisotopic Mass (M+H)⁺:
 - Unlabeled (C₁₈H₁₉³⁵ClO₃): 319.1095
 - Labeled (C₁₈H₁₄D₅³⁵ClO₃): 324.1409 (+5.0314 Da shift)
- Chlorine Signature: The spectrum must exhibit a 3:1 intensity ratio between the M+H (324) and M+H+2 (326) peaks, confirming the presence of one chlorine atom.

Fragmentation Logic

Fragmentation in ESI-MS/MS (qTOF or Orbitrap) typically cleaves the ether linkage.

- Parent Ion: m/z 324.14 ([M+H]⁺)
- Primary Fragment (Loss of Linker): Cleavage of the ether bond releases the d5-chlorohydroxypropyl chain.
 - Fragment: 225.10 (Unlabeled 2'-Hydroxy-3-phenylpropiophenone cation).
 - Insight: The loss of the label (neutral loss of ~99 Da) confirms the d5 is located on the linker, not the phenyl-propanone backbone.
- Secondary Fragment (Tropylium): m/z 91.05 (Benzyl cation from the distal phenyl ring).

NMR Spectroscopy Verification

NMR is the definitive tool for structural elucidation, specifically for proving the position of deuterium atoms (via signal silence).

¹H NMR (Proton Silence Strategy)

In the unlabeled impurity, the linker protons (O-CH₂-CH(OH)-CH₂-Cl) appear as a complex multiplet set between 3.5 ppm and 4.5 ppm. In the d5-analog, these signals must be absent.

Position	Unlabeled Shift (δ ppm)	d5-Labeled Shift	Structural Conclusion
Aromatic (Phenoxy)	6.9 - 7.8 (m, 4H)	6.9 - 7.8 (m, 4H)	Backbone Intact
Aromatic (Distal)	7.1 - 7.3 (m, 5H)	7.1 - 7.3 (m, 5H)	Backbone Intact
Linker (O-CH ₂)	~4.2 (m, 2H)	Silent	Site of Deuteration
Linker (CH-OH)	~4.1 (m, 1H)	Silent	Site of Deuteration
Linker (CH ₂ -Cl)	~3.7 (m, 2H)	Silent	Site of Deuteration
Tail (CO-CH ₂)	~3.3 (t, 2H)	~3.3 (t, 2H)	Unaffected
Tail (CH ₂ -Ph)	~3.0 (t, 2H)	~3.0 (t, 2H)	Unaffected

¹³C NMR (Carbon Coupling)

While ^1H NMR shows silence, ^{13}C NMR confirms the carbon backbone via C-D coupling.

- Linker Carbons: The three carbons of the propoxy chain will appear as septets (due to coupling with D, spin=1) with a slight upfield isotope shift compared to the unlabeled standard.
- Key Signals:
 - Carbonyl (C=O): ~200 ppm (Singlet).
 - C-Cl (Linker): ~45 ppm (Septet in d5).
 - C-O (Linker): ~70 ppm (Septet in d5).

Experimental Protocol: Purity & Identity Workflow

To validate the standard for use in GLP/GMP studies, follow this self-validating protocol.

Step-by-Step Validation

- Sample Prep: Dissolve 5 mg of **Depropylamino Chloro Propafenone-d5** in 0.6 mL DMSO-d6 (preferred over CDCl_3 to prevent OH exchange broadening).
- Acquisition:
 - Run ^1H NMR (16 scans).
 - Run ^{13}C NMR (1024 scans, proton-decoupled).
 - Run LC-MS (ESI+, gradient 5-95% ACN in Water + 0.1% Formic Acid).
- Data Check:
 - Check 1: Integrate aromatic region (9H total). Set as reference.
 - Check 2: Integrate 3.5-4.5 ppm region. Value should be $< 0.05\text{H}$ (indicating $>99\%$ isotopic enrichment).

- Check 3: Verify LC-MS retention time. The d5 analog typically elutes slightly earlier (0.1 - 0.2 min) than the unlabeled standard due to the deuterium isotope effect on lipophilicity.

Workflow Diagram (DOT)

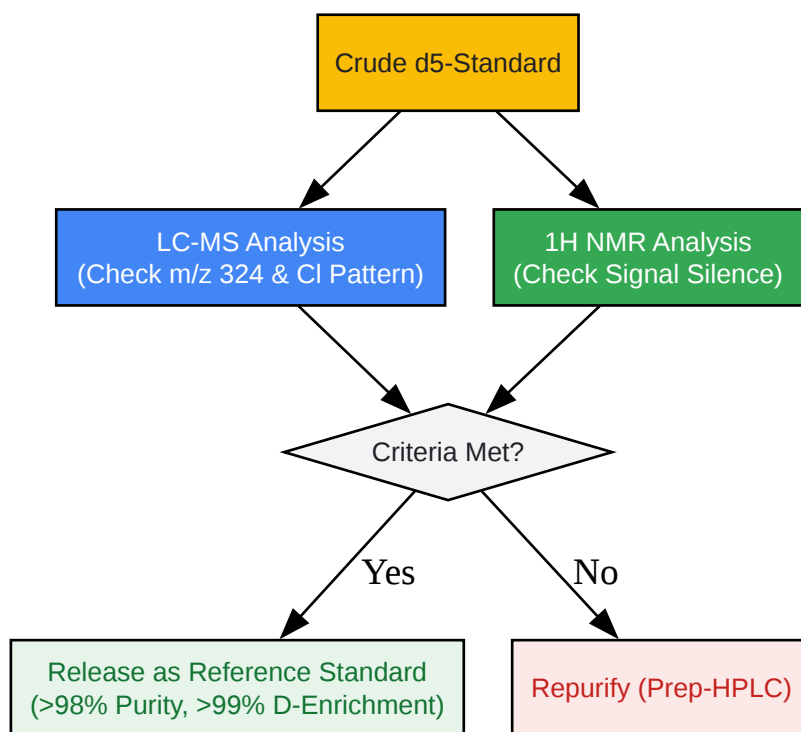

[Click to download full resolution via product page](#)

Figure 2: Analytical decision tree for the validation of the deuterated standard.

References

- European Pharmacopoeia (Ph. Eur.). Propafenone Hydrochloride Monograph 10.0. Strasbourg, France: EDQM. (Defines Impurity E structure).
- PubChem. Depropylamino chloro propafenone (Compound Summary). National Library of Medicine. Accessed 2025.[1][2] [Link](#)
- Cayman Chemical. Propafenone-d5 Product Insert & Spectral Data. (Reference for d5-labeling strategies in Propafenone series). [Link](#)

- Veeprho. Structure Elucidation Report: Propafenone EP Impurity E. (Industrial standard characterization). [Link](#)

Need Custom Synthesis?

BenchChem offers custom synthesis for rare earth carbides and specific isotopic labeling.

Email: info@benchchem.com or [Request Quote Online](#).

Sources

- 1. Propafenone | C₂₁H₂₇NO₃ | CID 4932 - PubChem [pubchem.ncbi.nlm.nih.gov]
- 2. Propafenone Hydrochloride | C₂₁H₂₈ClNO₃ | CID 36708 - PubChem [pubchem.ncbi.nlm.nih.gov]
- To cite this document: BenchChem. [Structure Elucidation of Depropylamino Chloro Propafenone-d₅]. BenchChem, [2026]. [Online PDF]. Available at: [<https://www.benchchem.com/product/b584960/docs#structure-elucidation-of-depropylamino-chloro-propafenone-d5>]

Disclaimer & Data Validity:

The information provided in this document is for Research Use Only (RUO) and is strictly not intended for diagnostic or therapeutic procedures. While BenchChem strives to provide accurate protocols, we make no warranties, express or implied, regarding the fitness of this product for every specific experimental setup.

Technical Support: The protocols provided are for reference purposes. Unsure if this reagent suits your experiment?

Need Industrial/Bulk Grade? [Request Custom Synthesis Quote](#)

BenchChem

Our mission is to be the trusted global source of essential and advanced chemicals, empowering scientists and researchers to drive progress in science and industry.

Contact

Address: 3281 E Guasti Rd

Ontario, CA 91761, United States

Phone: (601) 213-4426

Email: info@benchchem.com

[Contact our Ph.D. Support Team for a compatibility check](#)