

# Application Notes and Protocols for the Catalytic Synthesis of 3-Substituted Azetidines

**Author:** BenchChem Technical Support Team. **Date:** May 2026

## Compound of Interest

Compound Name: 3-(3-Chlorophenyl)azetidine

CAS No.: 1203798-86-0

Cat. No.: B584690

[Get Quote](#)

## Abstract

The azetidine scaffold is a cornerstone of modern medicinal chemistry, prized for its ability to impart favorable physicochemical properties such as increased metabolic stability, improved solubility, and reduced lipophilicity when incorporated into bioactive molecules.[1][2] As a rigid, three-dimensional bioisostere for various common functional groups, its presence in numerous FDA-approved drugs underscores its significance.[1] However, the synthesis of these four-membered rings is hampered by considerable ring strain, making their construction a formidable challenge.[3][4][5] This guide provides an in-depth overview and validated protocols for key catalytic methods that have revolutionized access to 3-substituted azetidines, targeting researchers, medicinal chemists, and process development professionals. We will explore cutting-edge techniques in transition-metal catalysis, strain-release driven synthesis, and photoredox catalysis, focusing on the mechanistic rationale behind each method and providing practical, step-by-step procedures.

## The Strategic Value of Catalysis in Azetidine Synthesis

Traditional methods for azetidine synthesis often involve multi-step sequences with harsh conditions and limited functional group tolerance.[1] Catalytic approaches offer elegant and efficient solutions, enabling direct C-H functionalization, asymmetric transformations, and the use of novel, highly reactive intermediates under mild conditions. These methods provide modular access to a diverse range of 3-substituted azetidines, accelerating the drug discovery process.

This document is structured around three transformative catalytic paradigms:

- **Transition-Metal Catalysis:** Leveraging the unique reactivity of metals like palladium, copper, and lanthanides to forge C-N and C-C bonds.
- **Strain-Release Driven Synthesis:** Harnessing the immense potential energy of highly strained precursors like 1-azabicyclo[1.1.0]butanes (ABBs) to drive thermodynamically favorable transformations.
- **Photoredox Catalysis:** Using visible light to generate reactive intermediates for cycloadditions and multicomponent reactions under exceptionally mild conditions.

## Transition-Metal Catalysis: Directing the Formation of the Azetidine Core

Transition metals provide a powerful toolkit for constructing the azetidine ring through mechanisms that would be otherwise inaccessible.

### Palladium-Catalyzed Intramolecular C(sp<sup>3</sup>)-H Amination

One of the most direct strategies for forming the azetidine ring is the intramolecular cyclization of an amine onto an unactivated C(sp<sup>3</sup>)-H bond. The Gaunt group demonstrated a landmark Pd(II)-catalyzed  $\gamma$ -C(sp<sup>3</sup>)-H amination that proceeds via a Pd(II)/Pd(IV) catalytic cycle.[3] The reaction is notable for its functional group tolerance and ability to form the strained four-membered ring directly.

**Mechanistic Insight:** The reaction is initiated by coordination of the picolinamide (PA) directing group to the Pd(II) catalyst. This is followed by C-H activation to form a palladacycle. Oxidation of the Pd(II) center to Pd(IV) by an oxidant like benziodoxole tosylate is a crucial step, which

then allows for the key C–N bond-forming reductive elimination to furnish the azetidine product and regenerate the active Pd(II) catalyst.[3]

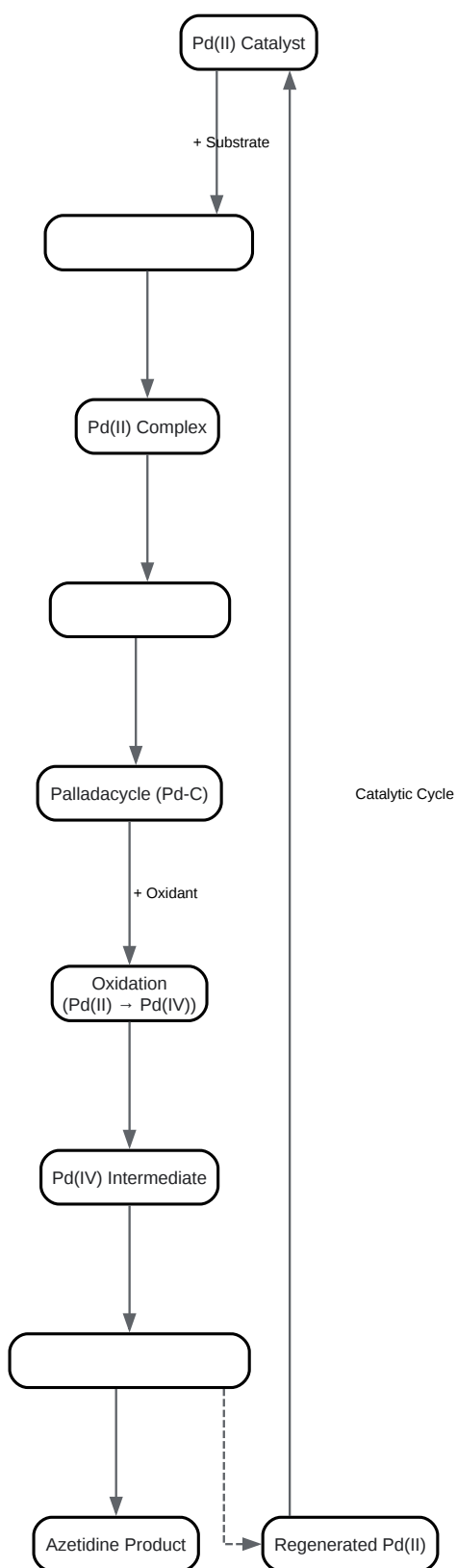

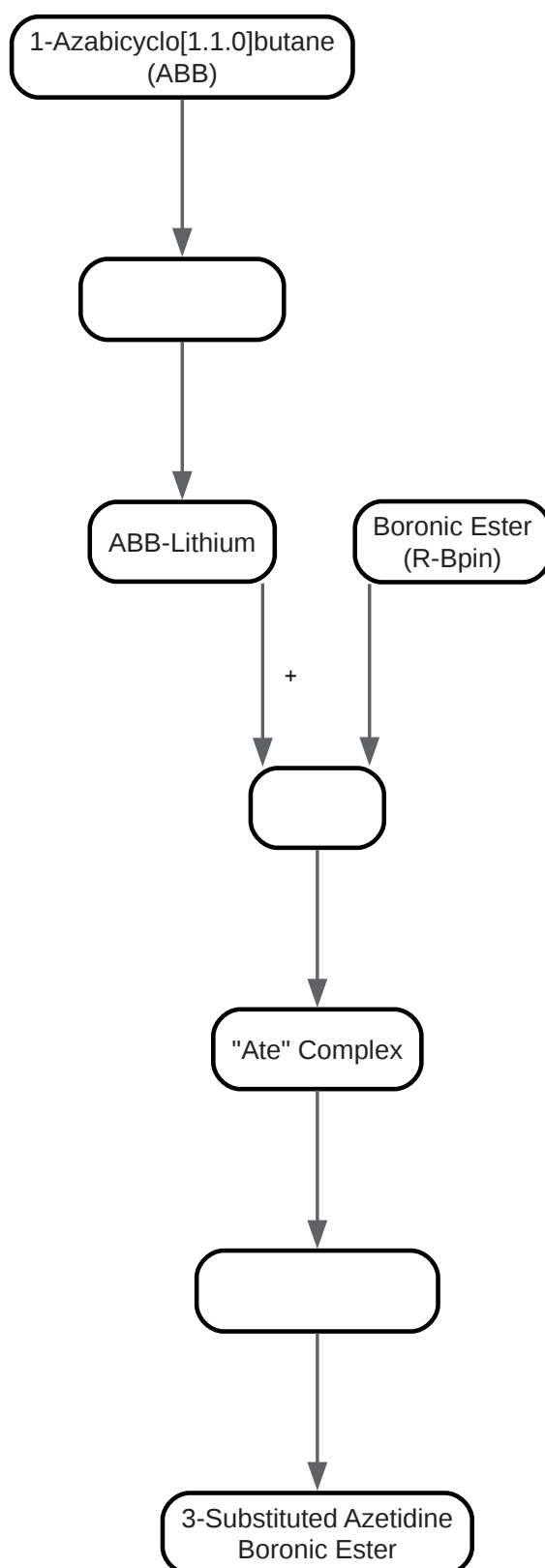

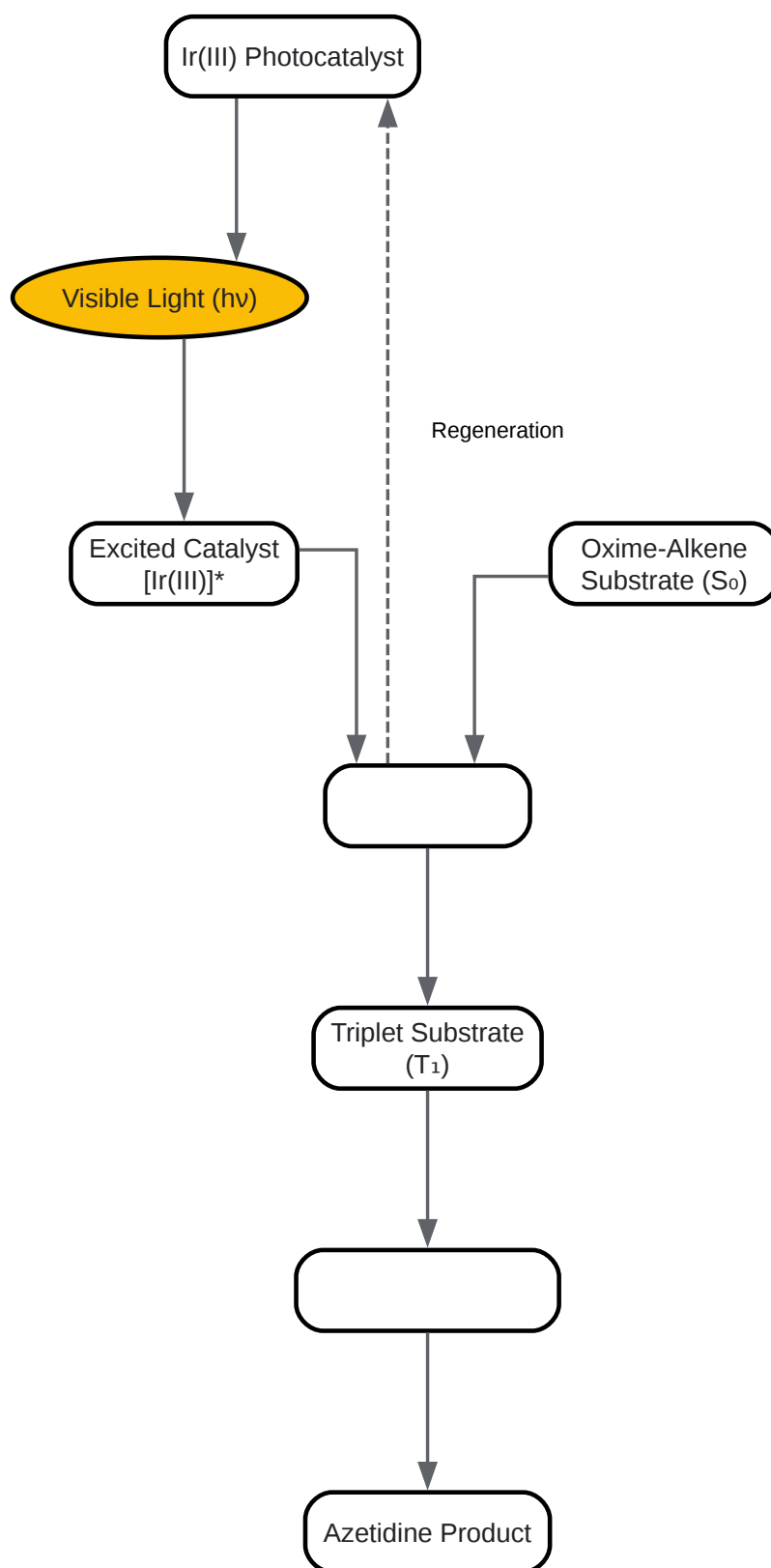

[Click to download full resolution via product page](#)

### Need Custom Synthesis?

BenchChem offers custom synthesis for rare earth carbides and specific isotopic labeling.

Email: [info@benchchem.com](mailto:info@benchchem.com) or [Request Quote Online](#).

## Sources

- [1. pubs.acs.org](https://pubs.acs.org) [[pubs.acs.org](https://pubs.acs.org)]
- [2. chemrxiv.org](https://chemrxiv.org) [[chemrxiv.org](https://chemrxiv.org)]
- [3. pubs.rsc.org](https://pubs.rsc.org) [[pubs.rsc.org](https://pubs.rsc.org)]
- [4. researchgate.net](https://researchgate.net) [[researchgate.net](https://researchgate.net)]
- 5. Recent advances in the synthesis and reactivity of azetidines: strain-driven character of the four-membered heterocycle - Organic & Biomolecular Chemistry (RSC Publishing) [[pubs.rsc.org](https://pubs.rsc.org)]
- To cite this document: BenchChem. [Application Notes and Protocols for the Catalytic Synthesis of 3-Substituted Azetidines]. BenchChem, [2026]. [Online PDF]. Available at: [<https://www.benchchem.com/product/b584690/docs#application-notes-and-protocols-for-the-catalytic-synthesis-of-3-substituted-azetidines>]

---

### Disclaimer & Data Validity:

The information provided in this document is for Research Use Only (RUO) and is strictly not intended for diagnostic or therapeutic procedures. While BenchChem strives to provide accurate protocols, we make no warranties, express or implied, regarding the fitness of this product for every specific experimental setup.

**Technical Support:** The protocols provided are for reference purposes. Unsure if this reagent suits your experiment?

**Need Industrial/Bulk Grade?** [Request Custom Synthesis Quote](#)

# BenchChem

Our mission is to be the trusted global source of essential and advanced chemicals, empowering scientists and researchers to drive progress in science and industry.

## Contact

Address: 3281 E Guasti Rd

Ontario, CA 91761, United States

Phone: (601) 213-4426

Email: [info@benchchem.com](mailto:info@benchchem.com)

[Contact our Ph.D. Support Team for a compatibility check](#)