

# An In-Depth Technical Guide to DM-4103: A Key Metabolite of Tolvaptan

**Author:** BenchChem Technical Support Team. **Date:** April 2026

## Compound of Interest

Compound Name:	DM-4103
CAS No.:	1346599-56-1
Cat. No.:	B584659

[Get Quote](#)

For Researchers, Scientists, and Drug Development Professionals

## Introduction

**DM-4103** is the principal active metabolite of Tolvaptan, a selective vasopressin V2-receptor antagonist.<sup>[1][2]</sup> Formed primarily in the liver via the cytochrome P450 3A4 (CYP3A4) enzyme system, **DM-4103** has garnered significant attention for its role in the pharmacological profile and potential hepatotoxicity of its parent drug, particularly in the context of long-term therapy for conditions such as Autosomal Dominant Polycystic Kidney Disease (ADPKD).<sup>[1][2][3]</sup> This technical guide provides a comprehensive overview of **DM-4103**, focusing on its mechanism of action, quantitative data from key in vitro studies, and detailed experimental protocols.

Chemical Identity:

- IUPAC Name: 4-[5-chloro-2-[[2-methyl-4-[(2-methylbenzoyl)amino]benzoyl]amino]phenyl]-4-oxobutanoic acid<sup>[4]</sup>
- Molecular Formula: C<sub>26</sub>H<sub>23</sub>ClN<sub>2</sub>O<sub>5</sub><sup>[4]</sup>

- Molecular Weight: 478.9 g/mol [4]

## Pharmacology and Mechanism of Action

While Tolvaptan exerts its primary therapeutic effect through vasopressin V2-receptor antagonism, the pharmacological activity of **DM-4103** is centered on its interaction with various hepatic transporters. This interaction is a critical factor in understanding the disposition and potential for drug-induced liver injury (DILI) associated with Tolvaptan.

The prevailing hypothesis for Tolvaptan-associated hepatotoxicity involves a multi-faceted mechanism driven by **DM-4103**:

- Inhibition of Bile Acid Efflux: **DM-4103** is a potent inhibitor of the Bile Salt Export Pump (BSEP), a key transporter responsible for the efflux of bile acids from hepatocytes into the bile canaliculi.[5][6] Inhibition of BSEP leads to the intracellular accumulation of cytotoxic bile acids.
- Mitochondrial Dysfunction: Accumulating evidence suggests that **DM-4103** can impair mitochondrial respiration, leading to decreased ATP production and increased oxidative stress within hepatocytes.[1][7]

This dual-hit mechanism of cholestasis and mitochondrial injury is believed to be a significant contributor to the liver injury observed in some patients receiving Tolvaptan.[1]

## Quantitative Data

The inhibitory activity of **DM-4103** on key human hepatic transporters has been quantified in vitro. The following table summarizes the reported half-maximal inhibitory concentration (IC50) values.

Transporter	Substrate	IC50 (μM)	Reference
BSEP (Bile Salt Export Pump)	Taurocholic Acid	4.15	[5]
MRP2 (Multidrug Resistance-associated Protein 2)	N/A	~51.0	[8]
MRP3 (Multidrug Resistance-associated Protein 3)	N/A	~44.6	[8]
MRP4 (Multidrug Resistance-associated Protein 4)	N/A	4.26	[8]
NTCP (Na <sup>+</sup> -Taurocholate Cotransporting Polypeptide)	Taurocholic Acid	16.3	[8]
OATP1B1 (Organic Anion Transporting Polypeptide 1B1)	N/A	N/A	[9][10]
OAT3 (Organic Anion Transporter 3)	N/A	N/A	[9]

Note: "N/A" indicates that while inhibition has been reported, specific IC50 values were not available in the reviewed literature.

## Experimental Protocols

### Synthesis of DM-4103

A detailed, reproducible laboratory synthesis protocol for **DM-4103** is outlined below, based on established chemical principles for amide bond formation and ring-opening reactions.

Starting Materials: 2-methyl-4-nitrobenzoic acid, 2-amino-4-chlorobenzoic acid, succinic anhydride.

Procedure:

- Step 1: Synthesis of 2-methyl-4-(2-methylbenzamido)benzoic acid.
  - Protect the carboxylic acid group of 2-methyl-4-nitrobenzoic acid.
  - Reduce the nitro group to an amine.
  - Couple the resulting amine with 2-methylbenzoyl chloride in the presence of a base (e.g., pyridine or triethylamine) to form the amide bond.
  - Deprotect the carboxylic acid.
- Step 2: Coupling with 2-amino-4-chlorobenzoic acid.
  - Activate the carboxylic acid of the product from Step 1 using a coupling agent (e.g., DCC or HBTU).
  - React the activated acid with the methyl ester of 2-amino-4-chlorobenzoic acid to form the second amide bond.
- Step 3: Formation of the oxobutanoic acid moiety.
  - Hydrolyze the methyl ester of the product from Step 2 to the corresponding carboxylic acid.
  - React the resulting aniline derivative with succinic anhydride in a suitable solvent (e.g., THF or DMF) to open the anhydride ring and form the final product, 4-[5-chloro-2-[[2-methyl-4-[(2-methylbenzoyl)amino]benzoyl]amino]phenyl]-4-oxobutanoic acid (**DM-4103**).
- Purification: The final product can be purified by recrystallization or column chromatography.

## In Vitro Hepatic Transporter Inhibition Assay (BSEP Example)

This protocol describes a common method for determining the IC50 value of a compound against the Bile Salt Export Pump (BSEP) using membrane vesicles.

#### Materials:

- Inside-out membrane vesicles from Sf9 cells overexpressing human BSEP.
- [3H]-Taurocholic acid (substrate).
- **DM-4103** (test inhibitor).
- ATP and AMP solutions.
- Scintillation fluid and counter.

#### Procedure:

- **Vesicle Preparation:** Thaw BSEP-expressing membrane vesicles on ice.
- **Reaction Setup:** In a 96-well plate, combine the membrane vesicles, [3H]-Taurocholic acid, and varying concentrations of **DM-4103**.
- **Initiation of Transport:** Initiate the transport reaction by adding ATP solution. Use AMP as a negative control (to measure non-ATP-dependent uptake).
- **Incubation:** Incubate the plate at 37°C for a predetermined time (e.g., 5-10 minutes).
- **Termination of Reaction:** Stop the reaction by adding ice-cold wash buffer and rapidly filtering the contents of each well through a filter plate to separate the vesicles from the surrounding medium.
- **Washing:** Wash the filters multiple times with ice-cold wash buffer to remove any unbound substrate.
- **Quantification:** Add scintillation fluid to each well and measure the amount of [3H]-Taurocholic acid retained in the vesicles using a scintillation counter.

- **Data Analysis:** Calculate the percentage of inhibition for each concentration of **DM-4103** compared to the vehicle control. Determine the IC50 value by fitting the data to a dose-response curve.

## Mitochondrial Respiration Assay (Seahorse XF Analyzer)

This protocol outlines the use of the Seahorse XF Analyzer to assess the effect of **DM-4103** on mitochondrial respiration in cultured hepatocytes.

### Materials:

- Cultured hepatocytes (e.g., HepG2 or primary human hepatocytes).
- Seahorse XF Cell Culture Microplates.
- Seahorse XF Calibrant solution.
- Assay medium (e.g., XF Base Medium supplemented with glucose, pyruvate, and glutamine).
- **DM-4103** (test compound).
- Mitochondrial stress test compounds: oligomycin, FCCP, and rotenone/antimycin A.

### Procedure:

- **Cell Seeding:** Seed hepatocytes in a Seahorse XF Cell Culture Microplate and allow them to attach and form a monolayer.
- **Sensor Cartridge Hydration:** Hydrate the sensor cartridge with Seahorse XF Calibrant solution overnight in a non-CO2 incubator at 37°C.
- **Compound Preparation:** Prepare a stock solution of **DM-4103** and the mitochondrial stress test compounds.
- **Assay Setup:**
  - Replace the cell culture medium with pre-warmed assay medium.

- Incubate the cells in a non-CO2 incubator at 37°C for one hour prior to the assay.
- Load the injection ports of the hydrated sensor cartridge with **DM-4103** and the mitochondrial stress test compounds.
- Seahorse XF Analyzer Operation:
  - Calibrate the instrument with the sensor cartridge.
  - Replace the calibration plate with the cell culture plate.
  - Run the assay protocol, which involves sequential injections of the compounds and measurement of the oxygen consumption rate (OCR).
- Data Analysis: Analyze the OCR data to determine the basal respiration, ATP-linked respiration, maximal respiration, and non-mitochondrial respiration in the presence and absence of **DM-4103**.

## Visualizations

### Signaling Pathway of DM-4103-Induced Hepatotoxicity

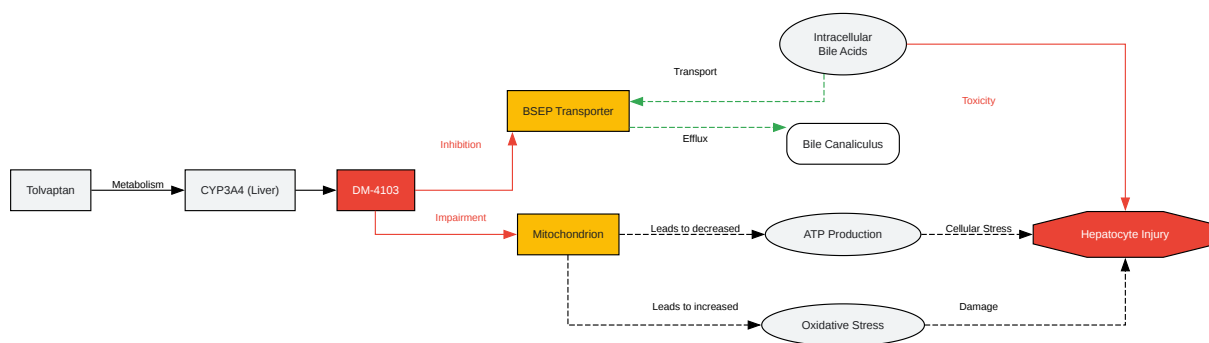

[Click to download full resolution via product page](#)

Caption: Proposed mechanism of **DM-4103**-induced hepatotoxicity.

## Experimental Workflow for In Vitro Assessment of **DM-4103**

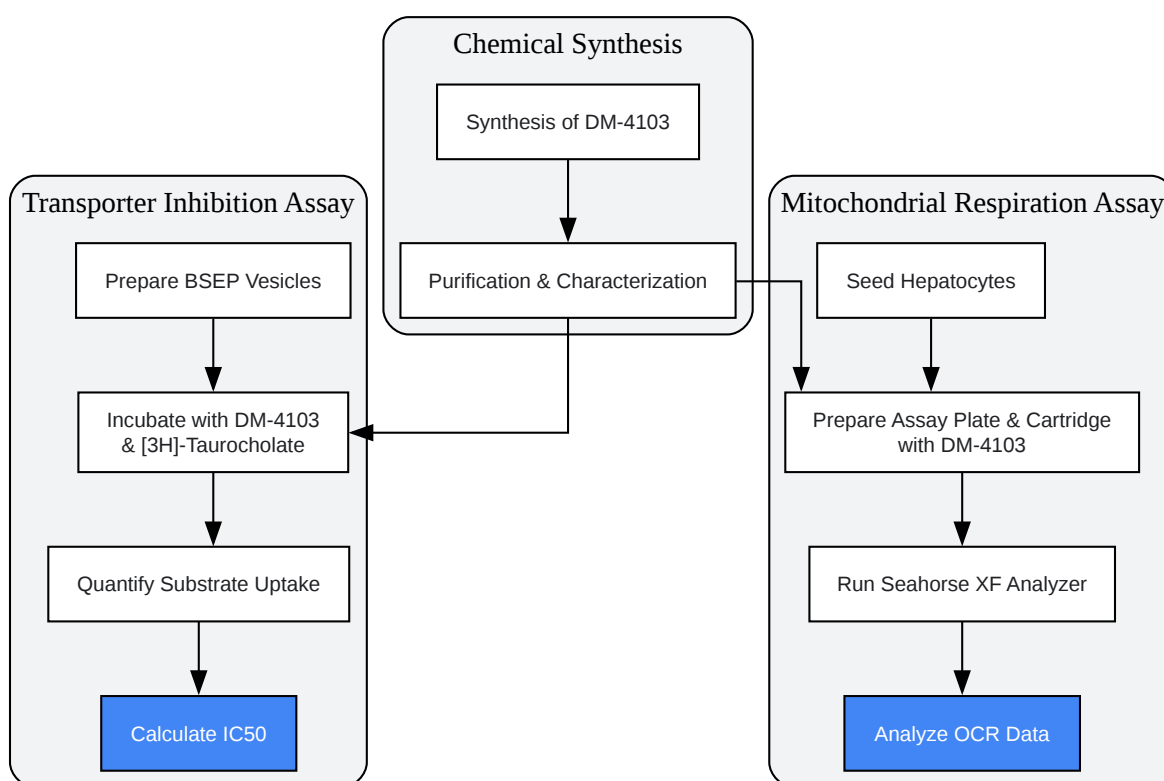

[Click to download full resolution via product page](#)

Caption: Workflow for the synthesis and in vitro evaluation of **DM-4103**.

### Need Custom Synthesis?

BenchChem offers custom synthesis for rare earth carbides and specific isotopic labeling.

Email: [info@benchchem.com](mailto:info@benchchem.com) or [Request Quote Online](#).

## References

- [1. Application of a Mechanistic Model to Evaluate Putative Mechanisms of Tolvaptan Drug-Induced Liver Injury and Identify Patient Susceptibility Factors - PMC \[pmc.ncbi.nlm.nih.gov\]](#)
- [2. academic.oup.com \[academic.oup.com\]](#)
- [3. Evaluation of tolvaptan-associated hepatic disorder using different national pharmacovigilance databases - PMC \[pmc.ncbi.nlm.nih.gov\]](#)
- [4. DM-4103 | C26H23ClN2O5 | CID 71752623 - PubChem \[pubchem.ncbi.nlm.nih.gov\]](#)
- [5. academic.oup.com \[academic.oup.com\]](#)
- [6. Hepatic Bile Acid Transporters and Drug-induced Hepatotoxicity - PMC \[pmc.ncbi.nlm.nih.gov\]](#)
- [7. Editor's Highlight: Candidate Risk Factors and Mechanisms for Tolvaptan-Induced Liver Injury Are Identified Using a Collaborative Cross Approach - PubMed \[pubmed.ncbi.nlm.nih.gov\]](#)
- [8. Inhibition of Human Hepatic Bile Acid Transporters by Tolvaptan and Metabolites: Contributing Factors to Drug-Induced Liver Injury? - PubMed \[pubmed.ncbi.nlm.nih.gov\]](#)
- [9. Regulatory guidelines do not accurately predict tolvaptan and metabolite interactions at BCRP, OATP1B1, and OAT3 transporters - PubMed \[pubmed.ncbi.nlm.nih.gov\]](#)
- [10. Potential amelioration of liver function by low-dose tolvaptan in heart failure patients - PMC \[pmc.ncbi.nlm.nih.gov\]](#)
- [To cite this document: BenchChem. \[An In-Depth Technical Guide to DM-4103: A Key Metabolite of Tolvaptan\]. BenchChem, \[2026\]. \[Online PDF\]. Available at: \[https://www.benchchem.com/product/b584659/docs#an-in-depth-technical-guide-to-dm-4103-a-key-metabolite-of-tolvaptan\]](#)

---

### Disclaimer & Data Validity:

The information provided in this document is for Research Use Only (RUO) and is strictly not intended for diagnostic or therapeutic procedures. While BenchChem strives to provide accurate protocols, we make no warranties, express or implied, regarding the fitness of this product for every specific experimental setup.

**Technical Support:** The protocols provided are for reference purposes. Unsure if this reagent suits your experiment?

**Need Industrial/Bulk Grade?** [Request Custom Synthesis Quote](#)

## BenchChem

Our mission is to be the trusted global source of essential and advanced chemicals, empowering scientists and researchers to drive progress in science and industry.

### Contact

Address: 3281 E Guasti Rd  
Ontario, CA 91761, United States  
Phone: (601) 213-4426  
Email: [info@benchchem.com](mailto:info@benchchem.com)

[Contact our Ph.D. Support Team for a compatibility check](#)