

troubleshooting inaccurate quantification with deuterated standards

Author: BenchChem Technical Support Team. **Date:** April 2026

Compound of Interest

Compound Name: *D-Galactose-4-d*

CAS No.: 478518-71-7

Cat. No.: B583699

[Get Quote](#)

Welcome to the LC-MS/MS Bioanalytical Technical Support Center. While stable isotope-labeled internal standards (SIL-IS) are universally recognized as the gold standard for correcting matrix effects and extraction variability, deuterated standards (d-IS) can exhibit anomalous physicochemical behaviors that severely compromise assay accuracy.

As a Senior Application Scientist, I have designed this guide to move beyond superficial fixes. Here, we will dissect the mechanistic root causes of deuterated standard failures—ranging from the deuterium isotope effect to hydrogen-deuterium (H/D) exchange—and provide field-proven, self-validating protocols to restore the scientific integrity of your quantitative assays.

Diagnostic Workflow: Isolating d-IS Failures

Before altering your method, use the following logical decision tree to isolate the specific mechanism causing your quantification failure.

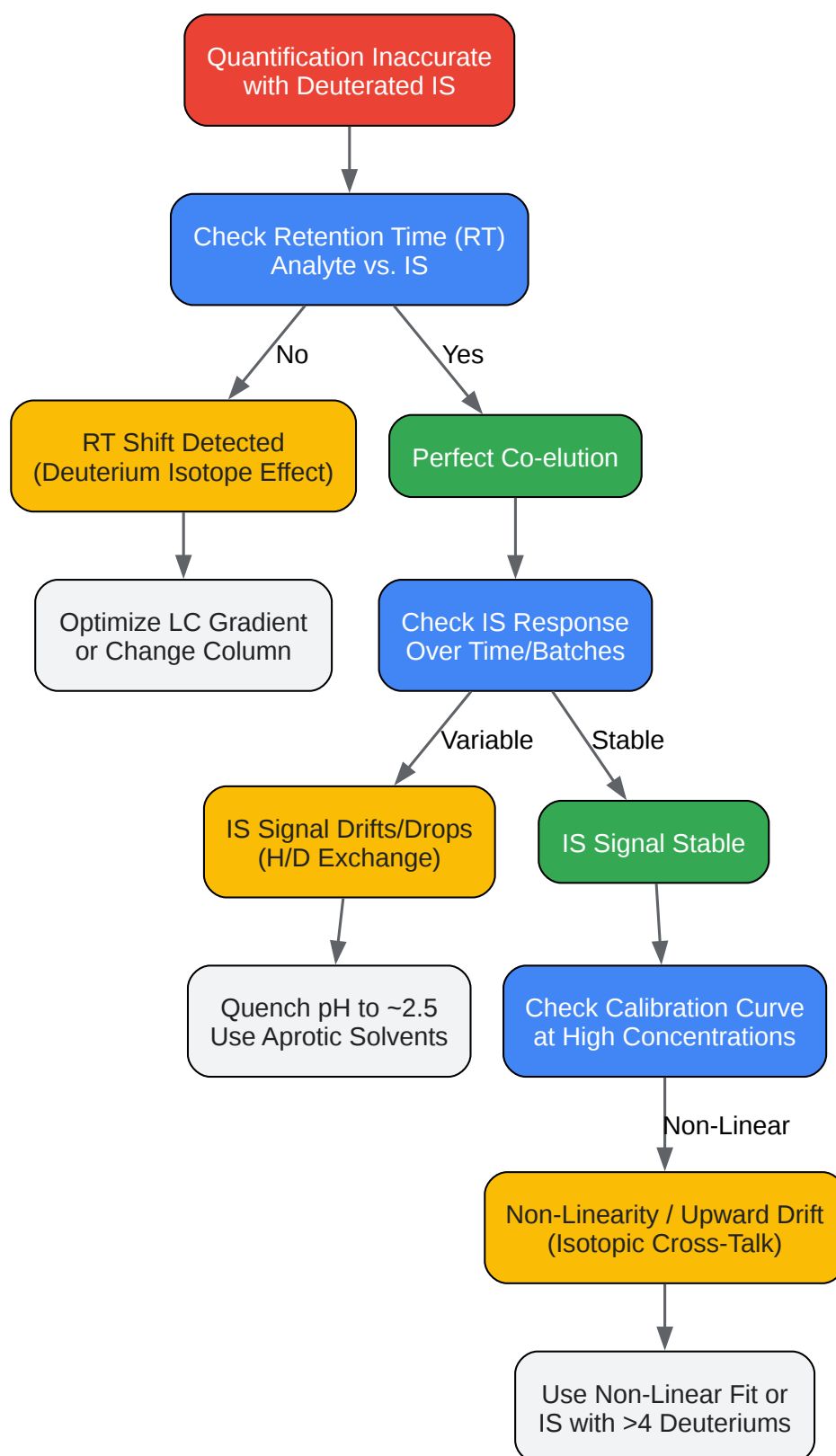

[Click to download full resolution via product page](#)

Diagnostic workflow for resolving inaccurate LC-MS/MS quantification with deuterated standards.

Troubleshooting Guides & FAQs

Q1: Why is my deuterated internal standard eluting earlier than my unlabeled analyte, and how does this affect my quantification? **The Causality:** You are observing the . The carbon-deuterium (C-D) bond has a lower zero-point vibrational energy than the carbon-hydrogen (C-H) bond, making it slightly shorter. This reduces the molar volume and polarizability of the deuterated molecule, rendering it slightly less lipophilic than its unlabeled counterpart. In reversed-phase liquid chromatography, this causes the d-IS to elute slightly earlier. **The Impact:** If the analyte and the d-IS do not perfectly co-elute, they enter the mass spectrometer ion source at different times. Consequently, they are subjected to different co-eluting matrix components, leading to differential matrix effects (unequal ion suppression or enhancement). This breaks the fundamental assumption of internal standardization: that the analyte/IS ratio remains constant regardless of matrix variability. **The Solution:** Flatten the LC gradient during the elution window or switch to an orthogonal stationary phase (e.g., Phenyl-Hexyl or Polar-Embedded instead of C18) to force co-elution. If co-elution cannot be achieved, consider switching to a ^{13}C or ^{15}N labeled standard, which are virtually immune to chromatographic shifts.

Q2: My calibration curve is non-linear at the high end, curving downwards. Is my deuterated standard failing? **The Causality:** You are experiencing [1\[1\]](#). Naturally occurring heavy isotopes (like ^{13}C , ^{37}Cl , ^{81}Br) in your unlabeled analyte create a predictable isotopic distribution (M+1, M+2, M+3, etc.). If your deuterated standard only has 2 or 3 deuterium atoms, the M+2 or M+3 isotope of a high-concentration unlabeled analyte will have the exact same nominal mass as the d-IS. At the Upper Limit of Quantification (ULOQ), this natural isotopic envelope contributes a massive false signal to the d-IS MRM transition[\[1\]](#). As the IS area artificially inflates, the Analyte/IS ratio drops, causing the calibration curve to plateau. **The Solution:** A standard rule in bioanalytical method development is that a SIL-IS should have a mass difference of at least +3 Da (preferably +4 to +6 Da) from the unlabeled analyte. If you must use a lightly deuterated standard, you are required to use a non-linear (quadratic) calibration regression to mathematically correct for the interference[\[1\]](#).

Q3: The absolute response of my deuterated standard drops significantly when samples are left in the autosampler overnight. What is happening? **The Causality:** This is symptomatic of

2[2]. Deuterium atoms on heteroatoms (O-D, N-D, S-D) exchange almost instantaneously in protic solvents. While deuterium on carbon is generally stable, it becomes highly labile if the carbon is adjacent to an electron-withdrawing group (like a carbonyl). This allows keto-enol tautomerization; in the enol form, the alpha-deuteron rapidly swaps with a proton from the aqueous mobile phase or sample matrix[2]. The Impact: As the d-IS loses deuterium atoms, its mass shifts back toward the unlabeled analyte. This decreases the IS signal (destroying precision) and artificially inflates the unlabeled analyte signal, causing massive positive bias in your calculated concentrations. The Solution: H/D exchange is catalyzed by basic conditions and accelerated by heat. To arrest this process, maintain strict "quench conditions." Keep the autosampler at 4°C and adjust the final sample extract to a low pH (typically ~2.5), where the base-catalyzed exchange rate is minimized[2].

Self-Validating Experimental Protocols

To ensure your assay meets regulatory rigor, such as the 3[3], you must definitively validate the root cause before implementing a fix.

Protocol A: Assessment of Differential Matrix Effects (Post-Column Infusion)

This protocol visualizes exactly how matrix suppression affects your analyte versus your IS.

- **Setup:** Plumb a syringe pump to deliver a constant flow of a neat mixed solution (Analyte + d-IS) into the LC eluent post-column, via a zero-dead-volume T-piece, just before it enters the MS ion source.
- **Injection:** Inject a blank matrix extract (e.g., extracted human plasma) using your standard LC gradient.
- **Monitoring:** Monitor the MRM transitions for both the analyte and the d-IS continuously.
- **Validation Logic:** The baseline will be elevated due to the constant syringe infusion. When the blank matrix components elute from the column, you will see dips in the baseline (ion suppression zones). If the retention times of your analyte and d-IS fall into a region where the suppression profile is changing rapidly (a steep slope in the dip), the slight RT shift

caused by the isotope effect will result in vastly different suppression factors for the two compounds. This proves differential matrix effects.

Protocol B: H/D Exchange Stability Stress Test

This protocol isolates chemical instability from instrument drift.

- **Preparation:** Spike the d-IS into your final extraction solvent (usually an aqueous/organic mixture). Do not add the unlabeled analyte.
- **Aliquoting:** Divide the solution into two sets. Set 1 is kept at 4°C (simulating ideal autosampler conditions). Set 2 is incubated at 37°C (stress conditions).
- **Time-Course Analysis:** Inject aliquots from both sets at $t = 0, 4, 8, 12,$ and 24 hours. Monitor both the d-IS MRM and the unlabeled analyte MRM.
- **Validation Logic:** If H/D exchange is occurring, you will observe a time-dependent decay in the d-IS peak area coupled with a stoichiometric increase in the unlabeled analyte peak area (as the d-IS converts back to the unlabeled form). If this occurs in Set 2 but not Set 1, temperature control is a viable mitigation strategy. If it occurs rapidly in both, you must alter the pH to quench the reaction or switch to a 100% aprotic reconstitution solvent.

Quantitative Impact Summary

The table below summarizes the expected quantitative deviations caused by these phenomena and the corresponding corrective actions.

Variable	Condition	Analyte/IS Ratio Bias (%)	Root Cause / Mechanism	Recommended Mitigation
Mass Difference	+2 Da (e.g., d2-IS)	+15% to +35% at ULOQ	Natural isotopic envelope (M+2) overlaps with IS	Use quadratic fitting or synthesize \geq d4-IS
Mass Difference	+4 Da (e.g., d4-IS)	< 2% at ULOQ	Negligible M+4 natural abundance	Standard linear regression (1/x ² weighting)
Solvent pH	pH 7.0 (Aqueous)	-40% IS response (24h)	Base-catalyzed H/D exchange at alpha-carbons	Quench extract to pH ~2.5
Autosampler Temp	25°C (Ambient)	-25% IS response (24h)	Thermal acceleration of proton exchange	Maintain autosampler strictly at 4°C

References

- Federal Register / FDA. Bioanalytical Method Validation; Guidance for Industry; Availability.
- Waters Corporation. The Use of Stable-Isotope-Labeled (SIL)
- ResearchGate.
- Benchchem.

Need Custom Synthesis?

BenchChem offers custom synthesis for rare earth carbides and specific isotopic labeling.

Email: info@benchchem.com or [Request Quote Online](#).

Sources

- [1. researchgate.net](https://www.researchgate.net) [researchgate.net]
- [2. benchchem.com](https://www.benchchem.com) [benchchem.com]
- [3. Federal Register :: Bioanalytical Method Validation; Guidance for Industry; Availability](https://www.federalregister.gov) [federalregister.gov]

- To cite this document: BenchChem. [troubleshooting inaccurate quantification with deuterated standards]. BenchChem, [2026]. [Online PDF]. Available at: [<https://www.benchchem.com/product/b583699/docs#troubleshooting-inaccurate-quantification-with-deuterated-standards>]

Disclaimer & Data Validity:

The information provided in this document is for Research Use Only (RUO) and is strictly not intended for diagnostic or therapeutic procedures. While BenchChem strives to provide accurate protocols, we make no warranties, express or implied, regarding the fitness of this product for every specific experimental setup.

Technical Support: The protocols provided are for reference purposes. Unsure if this reagent suits your experiment?

Need Industrial/Bulk Grade? [Request Custom Synthesis Quote](#)

BenchChem

Our mission is to be the trusted global source of essential and advanced chemicals, empowering scientists and researchers to drive progress in science and industry.

Contact

Address: 3281 E Guasti Rd
Ontario, CA 91761, United States
Phone: (601) 213-4426
Email: info@benchchem.com

[Contact our Ph.D. Support Team for a compatibility check](#)