

Technical Guide: Mechanism and Metabolic Flux Analysis of ^{13}C -2-FDG

Author: BenchChem Technical Support Team. **Date:** April 2026

Compound of Interest

Compound Name: 2-Deoxy-2-fluoro-D-glucose-1- ^{13}C

CAS No.: 478518-95-5

Cat. No.: B583549

[Get Quote](#)

Executive Summary: The "Silent" Metabolic Probe

While ^{18}F -FDG remains the clinical gold standard for positron emission tomography (PET), it suffers from a fundamental limitation: it detects the accumulation of a radiotracer but cannot chemically distinguish between the free substrate and the metabolized product in a single timeframe.

^{13}C -labeled 2-fluorodeoxyglucose (^{13}C -2-FDG) addresses this blind spot. When enhanced via Dissolution Dynamic Nuclear Polarization (d-DNP), this stable isotopologue allows for real-time, non-invasive quantification of Hexokinase (HK) activity. Unlike PET, ^{13}C -MRS (Magnetic Resonance Spectroscopy) resolves the distinct chemical shifts of free FDG and trapped FDG-6-Phosphate (FDG-6-P), providing a direct readout of glycolytic flux without the need for complex kinetic modeling assumptions.

This guide details the physicochemical mechanism, the metabolic trapping pathway, and the hyperpolarization protocols required to utilize ^{13}C -2-FDG in high-fidelity metabolic research.

Molecular Architecture & Chemical Physics

The Isotopologue Design

The power of ^{13}C -2-FDG lies in the synergy between two specific modifications to the glucose scaffold:

- **C2-Fluorine Substitution:** Replacing the hydroxyl group (-OH) at Carbon-2 with Fluorine (-F) creates a "metabolic dead-end." The fluorine atom is small enough (Van der Waals radius similar to -OH) to be accepted by Glucose Transporters (GLUT) and Hexokinase, but its electronegativity and lack of a proton prevent the isomerization required for the next step in glycolysis.
- **[1- ^{13}C] Labeling:** Carbon-13 is NMR-active.^{[1][2][3][4][5][6]} By labeling C1 (or occasionally C2), we create a spectral beacon. Under thermal equilibrium, the signal is too weak for in vivo use. However, C1 is often chosen for DNP applications to maximize spin-lattice relaxation times (), especially when coupled with backbone deuteration to suppress dipolar relaxation.

The DNP "Boost"

To make ^{13}C -2-FDG viable, the Boltzmann distribution of nuclear spins must be disrupted.

- **Thermal Equilibrium: Polarization**
(at 3T).^[4] Signal is invisible in real-time.
- **Hyperpolarized State: Polarization**
^[4] Signal enhanced by

This enhancement allows the detection of the conversion of FDG to FDG-6-P on a timescale of seconds, limited only by the

decay (typically 10–30 seconds for glucose analogs in vivo).

The Mechanism of Metabolic Trapping

The utility of ^{13}C -2-FDG rests on a specific enzymatic failure point. The molecule mimics glucose through uptake and phosphorylation but fails at isomerization.[7]

The Pathway Steps

- Facilitated Transport: ^{13}C -2-FDG enters the cytosol via GLUT1/GLUT3 transporters (upregulated in oncological models).
- Phosphorylation (The Signal Onset): Hexokinase (HK1/HK2) transfers a phosphate group from ATP to the C6 position, forming [1- ^{13}C]-2-FDG-6-Phosphate.
 - Spectroscopic Consequence: The addition of the phosphate group and the change in electronic environment induces a chemical shift change in the ^{13}C NMR spectrum (typically 2-3 ppm distinct from free FDG).
- Metabolic Blockade: The next enzyme, Phosphoglucose Isomerase (PGI), requires a hydroxyl group at C2 to facilitate the ring opening and isomerization to Fructose-6-Phosphate. The C2-Fluorine bond is chemically inert in this context.
- Accumulation: ^{13}C -2-FDG-6-P accumulates intracellularly.[8] In ^{13}C -MRS, this appears as the growth of a new peak over time, directly proportional to HK activity.

Visualization of the Signaling Pathway



[Click to download full resolution via product page](#)

Figure 1: The fluorine atom at C2 prevents isomerization, causing accumulation of the phosphorylated product.

Experimental Protocol: Hyperpolarized ^{13}C -MRS

This protocol describes the generation of hyperpolarized ^{13}C -2-FDG using a dissolution-DNP system (e.g., SpinLab or HyperSense).

Sample Formulation

The "glassing" ability of the sample is critical for efficient DNP.

- Substrate: 20–50 mg of $[1-^{13}\text{C}]\text{-2-FDG}$.
- Radical: 15 mM OX063 Trityl radical (provides the unpaired electrons for polarization transfer).
- Glassing Agent: No additional solvent is usually needed if the FDG/Radical mix forms an amorphous glass upon freezing. If crystallization occurs, add trace amounts of DMSO or Glycerol.
- Gd-Doping: 1-2 mM Gd-chelate (e.g., ProHance) to shorten electron and improve polarization buildup rate.

DNP Polarization Cycle

- Loading: Insert sample cup into the DNP polarizer.^[9]
- Conditions: Cool to 0.8 – 1.4 K in a 3.35 T (or 5 T) magnetic field.
- Irradiation: Apply microwave irradiation at the electron Larmor frequency (GHz for 3.35 T).
- Buildup: Monitor ^{13}C signal buildup for 60–90 minutes until saturation (typically 20–40% polarization).

Dissolution and Injection

Critical Step: Speed is paramount to minimize decay.

- **Dissolution:** Rapidly inject superheated buffer (Tris/EDTA or Phosphate buffered saline, pH 7.4, 180°C) into the sample cup.
- **Neutralization:** The final solution should be at physiological temperature (37°C) and pH.
- **Transfer:** Transfer to the NMR spectrometer or MRI scanner via a magnetic tunnel (to preserve spin orientation).
- **Injection:** Intravenous tail vein injection (mouse/rat) typically within 10–15 seconds of dissolution.

Data Acquisition (¹³C-MRS)

- **Sequence:** Slice-selective ¹³C-CSI (Chemical Shift Imaging) or simple pulse-and-acquire spectroscopy.
- **Flip Angle:** Small flip angles (5°–10°) are used initially to preserve magnetization for temporal binning (dynamic acquisition).
- **Readout:** Acquire spectra every 1–3 seconds for 60 seconds.

Workflow Visualization

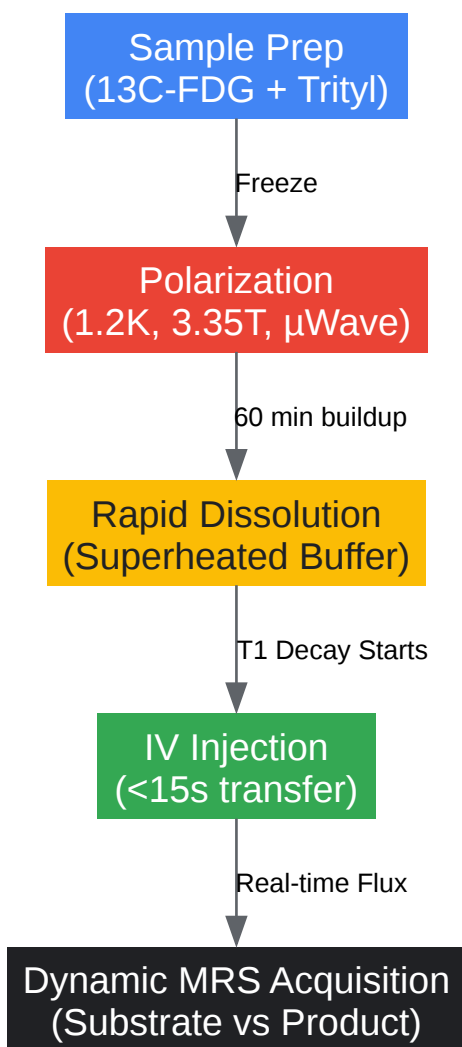

Figure 2: Dissolution DNP Workflow for ^{13}C -2-FDG

[Click to download full resolution via product page](#)

Figure 2: The critical path from sample preparation to data acquisition.

Data Interpretation & Comparison

The resulting spectra will display two primary peaks. The kinetic rate constant (

) describing the conversion of FDG to FDG-6-P is the quantitative metric of Hexokinase activity.

Spectral Signatures

- Peak A (Substrate): $[1-^{13}\text{C}]\text{-2-FDG}$ (

and

anomers may be resolved depending on field strength).

- Peak B (Product): [1-¹³C]-2-FDG-6-P. Shifted downfield (typically 2-3 ppm relative to substrate).

Comparison: ¹³C-FDG (MRS) vs. ¹⁸F-FDG (PET)[1][3]

Feature	¹⁸ F-FDG (PET)	Hyperpolarized ¹³ C-2-FDG (MRS)
Detection Basis	Gamma radiation (Positron annihilation)	Magnetic resonance (Nuclear spin)
Chemical Specificity	None. Cannot distinguish FDG from FDG-6-P.	High. Resolves Substrate vs. Product peaks.
Quantification	Requires kinetic modeling (Patlak plot) and assumptions about "lumped constant".	Direct ratiometric measurement of conversion ().
Temporal Resolution	Minutes (Accumulation phase).	Seconds (Real-time enzymatic flux).
Radiation Dose	Yes (Ionizing radiation).	None (Safe, stable isotope).
Sensitivity	Extremely High (Picomolar).	Moderate (Millimolar) - requires DNP.

References

- Commentary on Hyperpolarized ¹³C MRI: Kurhanewicz, J., et al.[4] "Hyperpolarized ¹³C MRI: Path to Clinical Translation in Oncology." Neoplasia, 2011. [\[Link\]](#)
- Mechanism of FDG Trapping (¹⁸F Context applicable to ¹³C): Phelps, M. E. "PET: The Merging of Biology and Imaging into Molecular Imaging." Journal of Nuclear Medicine, 2000. [\[Link\]](#)

- DNP Experimental Protocols: Ardenkjaer-Larsen, J. H., et al.[10] "Increase in signal-to-noise ratio of > 10,000 times in liquid-state NMR." PNAS, 2003. [[Link](#)]
- Metabolic Imaging Reviews: Brindle, K. M., et al. "Tumor imaging with hyperpolarized ¹³C magnetic resonance spectroscopy." Magnetic Resonance in Medicine, 2011. [[Link](#)]

Need Custom Synthesis?

BenchChem offers custom synthesis for rare earth carbides and specific isotopic labeling.

Email: info@benchchem.com or [Request Quote Online](#).

Sources

- 1. eprints.whiterose.ac.uk [eprints.whiterose.ac.uk]
- 2. chemrxiv.org [chemrxiv.org]
- 3. [Frontiers | Potential Clinical Roles for Metabolic Imaging with Hyperpolarized \[1-¹³C\]Pyruvate](https://www.frontiersin.org) [[frontiersin.org](https://www.frontiersin.org)]
- 4. [Hyperpolarized ¹³C MRI: State of the Art and Future Directions - PMC](https://pubmed.ncbi.nlm.nih.gov/) [[pmc.ncbi.nlm.nih.gov](https://pubmed.ncbi.nlm.nih.gov/)]
- 5. [Hyperpolarized ¹³C Metabolic Magnetic Resonance Spectroscopy and Imaging - PMC](https://pubmed.ncbi.nlm.nih.gov/) [[pmc.ncbi.nlm.nih.gov](https://pubmed.ncbi.nlm.nih.gov/)]
- 6. mr.copernicus.org [mr.copernicus.org]
- 7. int.livhospital.com [int.livhospital.com]
- 8. [Imaging of Tumour Metabolism: 18-FDG PET | Radiology Key](https://radiologykey.com) [radiologykey.com]
- 9. youtube.com [youtube.com]
- 10. [Cellular Origin and Molecular Mechanisms of 18F-FDG Uptake: Is There a Contribution of the Endothelium? | Journal of Nuclear Medicine](https://jnm.snmjournals.org) [jnm.snmjournals.org]
- To cite this document: BenchChem. [Technical Guide: Mechanism and Metabolic Flux Analysis of ¹³C-2-FDG]. BenchChem, [2026]. [Online PDF]. Available at: [<https://www.benchchem.com/product/b583549/docs#technical-guide-mechanism-and-metabolic-flux-analysis-of-13c-2-fdg>]

Disclaimer & Data Validity:

The information provided in this document is for Research Use Only (RUO) and is strictly not intended for diagnostic or therapeutic procedures. While BenchChem strives to provide accurate protocols, we make no warranties, express or implied, regarding the fitness of this product for every specific experimental setup.

Technical Support: The protocols provided are for reference purposes. Unsure if this reagent suits your experiment?

Need Industrial/Bulk Grade? [Request Custom Synthesis Quote](#)

BenchChem

Our mission is to be the trusted global source of essential and advanced chemicals, empowering scientists and researchers to drive progress in science and industry.

Contact

Address: 3281 E Guasti Rd
Ontario, CA 91761, United States
Phone: (601) 213-4426
Email: info@benchchem.com

[Contact our Ph.D. Support Team for a compatibility check](#)