

# Functionalization of 3-(methylthio)benzofuran for library generation

**Author:** BenchChem Technical Support Team. **Date:** May 2026

## Compound of Interest

Compound Name: 3-(Methylthio)benzofuran

CAS No.: 144499-28-5

Cat. No.: B583666

[Get Quote](#)

Application Note: Orthogonal Functionalization of **3-(Methylthio)benzofuran** for Diversity-Oriented Synthesis

## Strategic Overview: The Sulfur Linchpin

In the architecture of small-molecule libraries, the benzofuran core is a privileged scaffold, appearing frequently in anti-arrhythmic agents (e.g., Amiodarone), antitumor candidates, and antimicrobial compounds. However, standard benzofuran synthesis often locks the substitution pattern early.

The **3-(methylthio)benzofuran** scaffold offers a unique advantage for Diversity-Oriented Synthesis (DOS) because the sulfur atom acts as a "linchpin"—a functional handle that serves three distinct orthogonal roles:

- **Electronic Activator:** The sulfide lone pairs activate the C-2 position for direct C-H functionalization.
- **Leaving Group:** Under Liebeskind-Srogl conditions, the C-S bond can be excised and replaced with a C-C bond, effectively deleting the sulfur trace.

- Polarity Switch: Controlled oxidation transforms the lipophilic sulfide (–SMe) into a polar sulfoxide (–SOMe) or a strongly electron-withdrawing sulfone (–SO<sub>2</sub>Me), radically altering the physicochemical profile (logP, tPSA) of the library members.

This guide details the protocols to exploit these vectors for maximum chemical space coverage.

## Divergent Synthesis Workflow

The following decision tree illustrates the three primary vectors for functionalizing the core scaffold.

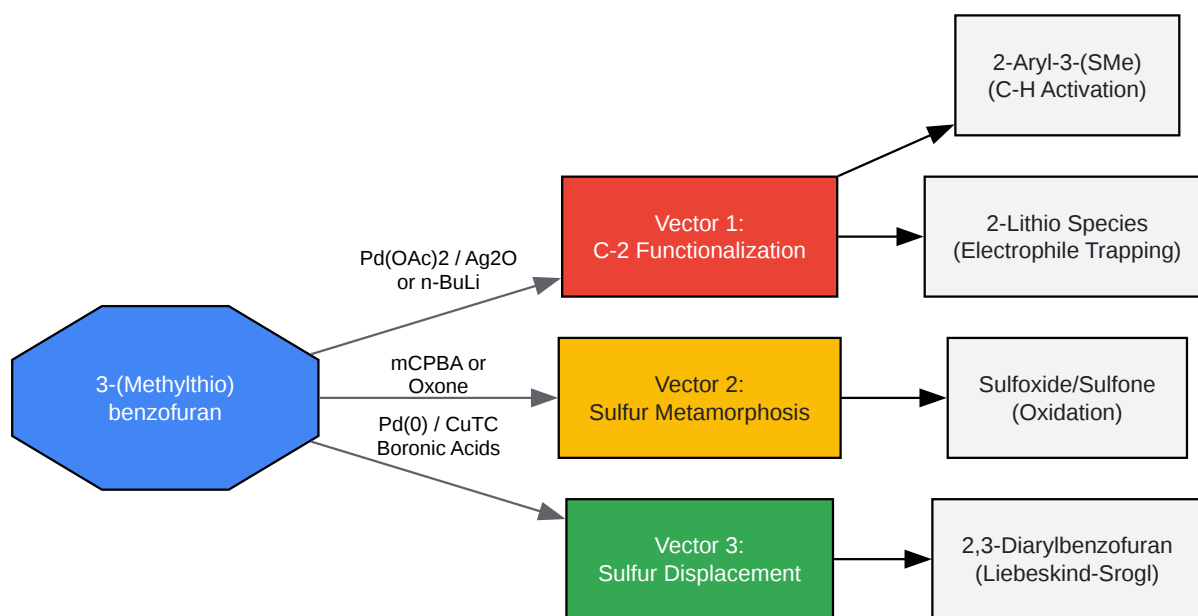

[Click to download full resolution via product page](#)

Figure 1: Divergent functionalization strategy. The 3-SMe group enables C-2 functionalization (Vector 1), polarity modulation (Vector 2), and C-3 substitution (Vector 3).

## Module 1: C-2 Functionalization (The Primary Vector)

The C-2 position is the most reactive site on the benzofuran ring. The 3-SMe group reinforces this reactivity through inductive effects and potential chelation.

## Protocol A: Pd-Catalyzed C-H Arylation (Green Chemistry Approach)

Why this works: Direct C-H activation avoids the need for pre-functionalization (e.g., C-2 bromination). The use of Hexafluoroisopropanol (HFIP) as a solvent is critical; it stabilizes the Pd-intermediate and lowers the activation energy for C-H cleavage via a Concerted Metalation-Deprotonation (CMD) pathway.

Reagents:

- Substrate: **3-(methylthio)benzofuran** (1.0 equiv)
- Aryl Iodide (1.5 equiv)
- Catalyst: Pd(OAc)<sub>2</sub> (5 mol%)
- Ligand: None required in HFIP (or PPh<sub>3</sub> if using dioxane)
- Base: Ag<sub>2</sub>O (1.0 equiv) or K<sub>2</sub>CO<sub>3</sub> (2.0 equiv)
- Solvent: HFIP (0.2 M)

Step-by-Step:

- Charge a flame-dried Schlenk tube with Pd(OAc)<sub>2</sub> (5 mol%), Ag<sub>2</sub>O (1.0 equiv), and the aryl iodide (1.5 equiv).
- Add **3-(methylthio)benzofuran** (1.0 equiv) dissolved in HFIP.
- Seal the tube and stir at Room Temperature for 16–24 hours. (Note: HFIP often allows RT reaction; if conversion is low, heat to 50°C).
- Validation: Monitor TLC. The product will be less polar than the starting material.
- Filter through a Celite pad to remove silver salts. Concentrate and purify via flash chromatography (Hexanes/EtOAc).

## Protocol B: Regioselective Lithiation

Why this works: The oxygen atom and the sulfur atom at C-3 create a "chelation pocket" that directs n-BuLi exclusively to C-2. This is superior to electrophilic substitution for introducing non-aryl groups (e.g., formyl, silyl, alkyl).

Step-by-Step:

- Dissolve **3-(methylthio)benzofuran** in anhydrous THF (0.1 M) under Argon.
- Cool to -78°C.
- Add n-BuLi (1.1 equiv, 2.5 M in hexanes) dropwise over 10 minutes.
- Stir for 30 minutes at -78°C. The solution typically turns yellow/orange, indicating the lithiated species.
- Add the electrophile (e.g., DMF, MeI, TMSCl) (1.2 equiv).
- Allow to warm to RT over 2 hours. Quench with sat. NH<sub>4</sub>Cl.[1]

## Module 2: Sulfur Displacement (The Orthogonal Vector)

The Liebeskind-Srogl coupling is the defining transformation for this scaffold. Unlike Suzuki or Stille couplings which require halides, this reaction uses the C-S bond as the electrophile. This allows you to carry the sulfur through early steps (as a protecting group/activator) and delete it at the end to install a carbon substituent.

Critical Mechanism: Standard Pd-catalysis fails here because sulfur poisons the catalyst. Copper(I) thiophene-2-carboxylate (CuTC) is required as a cofactor to coordinate the sulfur, facilitating the transmetalation step.

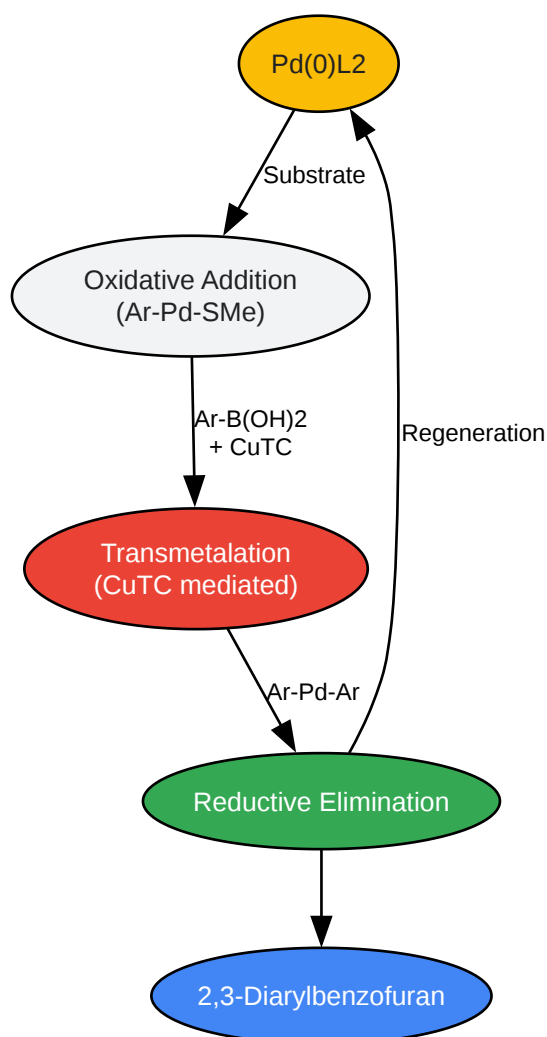

[Click to download full resolution via product page](#)

Figure 2: Liebeskind-Srogl Catalytic Cycle. CuTC sequesters the sulfur, preventing Pd poisoning.

Protocol:

- Safety: Perform in a glovebox or under strict Schlenk conditions.
- Combine **3-(methylthio)benzofuran** derivative (1.0 equiv), Boronic Acid (1.5 equiv), and CuTC (1.5–2.0 equiv).
- Add Pd(PPh<sub>3</sub>)<sub>4</sub> (5–10 mol%).
- Add degassed THF (0.1 M).

- Heat to 50–60°C for 12 hours.
- Workup: The reaction mixture will be dark. Filter through a silica plug to remove copper residues before standard aqueous workup.

## Module 3: Polarity Modulation (Oxidation)

Transforming the sulfide to a sulfone changes the group from an Electron Donating Group (EDG) to a strong Electron Withdrawing Group (EWG). This is useful for Structure-Activity Relationship (SAR) studies to probe electronic requirements in the binding pocket.

Data Summary: Oxidation Conditions

Target	Oxidant	Equiv	Conditions	Selectivity
Sulfoxide (S=O)	Oxone	0.5	MeOH/H <sub>2</sub> O, 0°C	High (>90%)
Sulfoxide (S=O)	H <sub>2</sub> O <sub>2</sub>	1.1	HFIP, RT	High
Sulfone (O=S=O)	mCPBA	2.5	DCM, RT	Complete

Protocol (Sulfone Synthesis):

- Dissolve substrate in DCM (0.1 M).
- Add m-CPBA (2.5 equiv) portion-wise at 0°C.
- Warm to RT and stir for 2 hours.
- Quench: Add sat. Na<sub>2</sub>S<sub>2</sub>O<sub>3</sub> (to kill excess peroxide) and sat. NaHCO<sub>3</sub> (to neutralize acid).
- Caution: Sulfones are highly polar; adjust chromatography gradients accordingly (often requires 50-100% EtOAc).

## References

- C-H Arylation in HFIP: Colletto, C., et al. "Room temperature C-H arylation of benzofurans by aryl iodides." *Chemical Science*, 2017.

- Liebeskind-Srogl Coupling: Villalobos, J.M., et al. "Pd-Catalyzed C–S Activation for [3 + 3] Annulation of 2-(Methylthio)benzofuran-3-carboxylates." *Journal of Organic Chemistry*, 2013.
- General Benzofuran Functionalization: Chatterjee, N., et al. "Recent Developments in C–H Functionalisation of Benzofurans and Benzothiophenes." *European Journal of Organic Chemistry*, 2020.
- Oxidation Protocols: Bahrami, K., et al. "TAPC-Promoted Oxidation of Sulfides." [2] *Journal of Organic Chemistry*, 2010. [2][3]

### Need Custom Synthesis?

BenchChem offers custom synthesis for rare earth carbides and specific isotopic labeling.

Email: [info@benchchem.com](mailto:info@benchchem.com) or [Request Quote Online](#).

## Sources

- 1. [Organic Syntheses Procedure \[orgsyn.org\]](http://orgsyn.org)
- 2. [Sulfoxide synthesis by oxidation \[organic-chemistry.org\]](http://organic-chemistry.org)
- 3. [Benzofuran synthesis \[organic-chemistry.org\]](http://organic-chemistry.org)
- To cite this document: BenchChem. [Functionalization of 3-(methylthio)benzofuran for library generation]. BenchChem, [2026]. [Online PDF]. Available at: [\[https://www.benchchem.com/product/b583666/docs#functionalization-of-3-methylthio-benzofuran-for-library-generation\]](https://www.benchchem.com/product/b583666/docs#functionalization-of-3-methylthio-benzofuran-for-library-generation)

---

### Disclaimer & Data Validity:

The information provided in this document is for Research Use Only (RUO) and is strictly not intended for diagnostic or therapeutic procedures. While BenchChem strives to provide accurate protocols, we make no warranties, express or implied, regarding the fitness of this product for every specific experimental setup.

**Technical Support:** The protocols provided are for reference purposes. Unsure if this reagent suits your experiment?

**Need Industrial/Bulk Grade?** [Request Custom Synthesis Quote](#)

## BenchChem

Our mission is to be the trusted global source of essential and advanced chemicals, empowering scientists and researchers to drive progress in science and industry.

### Contact

Address: 3281 E Guasti Rd  
Ontario, CA 91761, United States  
Phone: (601) 213-4426  
Email: [info@benchchem.com](mailto:info@benchchem.com)

[Contact our Ph.D. Support Team for a compatibility check](#)