

theoretical reactivity of 5-Bromo-2-methoxypyrimidin-4-amine

Author: BenchChem Technical Support Team. **Date:** December 2025

Compound of Interest

Compound Name: 5-Bromo-2-methoxypyrimidin-4-amine

Cat. No.: B582765

[Get Quote](#)

An In-depth Technical Guide to the Theoretical Reactivity of **5-Bromo-2-methoxypyrimidin-4-amine**

Abstract

5-Bromo-2-methoxypyrimidin-4-amine is a highly functionalized heterocyclic compound of significant interest to researchers in medicinal chemistry and drug development. Its substituted pyrimidine core offers multiple reaction sites, allowing for strategic molecular diversification. This technical guide provides a comprehensive analysis of the theoretical reactivity of **5-Bromo-2-methoxypyrimidin-4-amine**, focusing on the influence of its distinct functional groups on its chemical behavior. Key reaction classes, including palladium-catalyzed cross-coupling reactions and substitutions at the amino group, are discussed in detail. This document serves as a resource for scientists, providing detailed experimental protocols and structured data to facilitate the design and execution of synthetic strategies involving this versatile building block.

Overview of Molecular Structure and Reactivity

The reactivity of **5-Bromo-2-methoxypyrimidin-4-amine** is governed by the electronic properties of the pyrimidine ring and its substituents: the bromo, methoxy, and amino groups. The pyrimidine ring is inherently electron-deficient, which activates it towards nucleophilic attack, particularly at the 2, 4, and 6 positions.^{[1][2]} Conversely, electrophilic substitution is

generally difficult on an unactivated pyrimidine ring but preferentially occurs at the C5 position.

[2]

The key reactive sites on **5-Bromo-2-methoxypyrimidin-4-amine** are:

- The C5-Bromo Group: This is the most prominent site for transformations, primarily through palladium-catalyzed cross-coupling reactions. The carbon-bromine bond is significantly more reactive than carbon-chlorine bonds in such reactions, allowing for high chemoselectivity.[3]
[4]
- The C4-Amino Group: The primary amine is a nucleophilic center and can participate in reactions such as acylation, alkylation, and condensation.[5]
- The C2-Methoxy Group: This group is generally stable but can be susceptible to nucleophilic displacement under forcing conditions.
- The Pyrimidine Nitrogens: The lone pairs on the nitrogen atoms provide basic sites for protonation or alkylation.[6]

The interplay of these functional groups dictates the regioselectivity of its reactions, making it a predictable and valuable synthetic intermediate.

Figure 1: Theoretical Reactivity Map

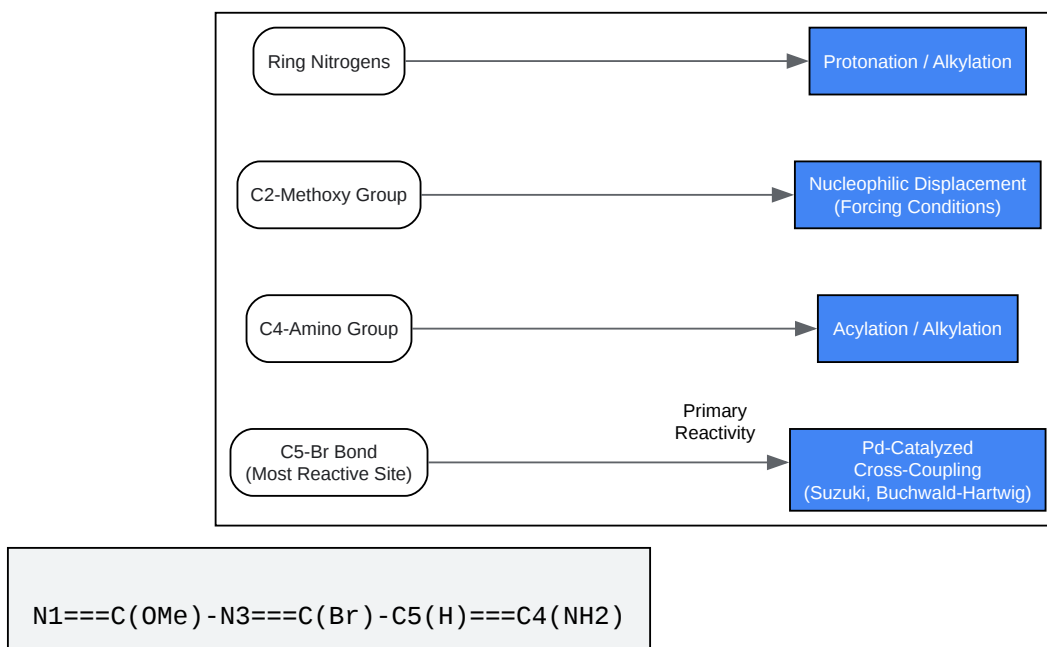

[Click to download full resolution via product page](#)

Figure 1: Theoretical Reactivity Map.

Palladium-Catalyzed Cross-Coupling Reactions at C5

The C5-bromo position is the principal site for carbon-carbon and carbon-nitrogen bond formation via palladium-catalyzed cross-coupling reactions. The general order of reactivity for aryl halides in these reactions is $I > Br > Cl > F$.^[3] This inherent reactivity allows for selective functionalization at the C5 position.

Suzuki-Miyaura Coupling

The Suzuki-Miyaura coupling is a versatile method for forming C-C bonds by reacting the aryl halide with an organoboron compound, such as an arylboronic acid.[4] This reaction is expected to proceed selectively at the C5-bromo position of **5-Bromo-2-methoxypyrimidin-4-amine**.

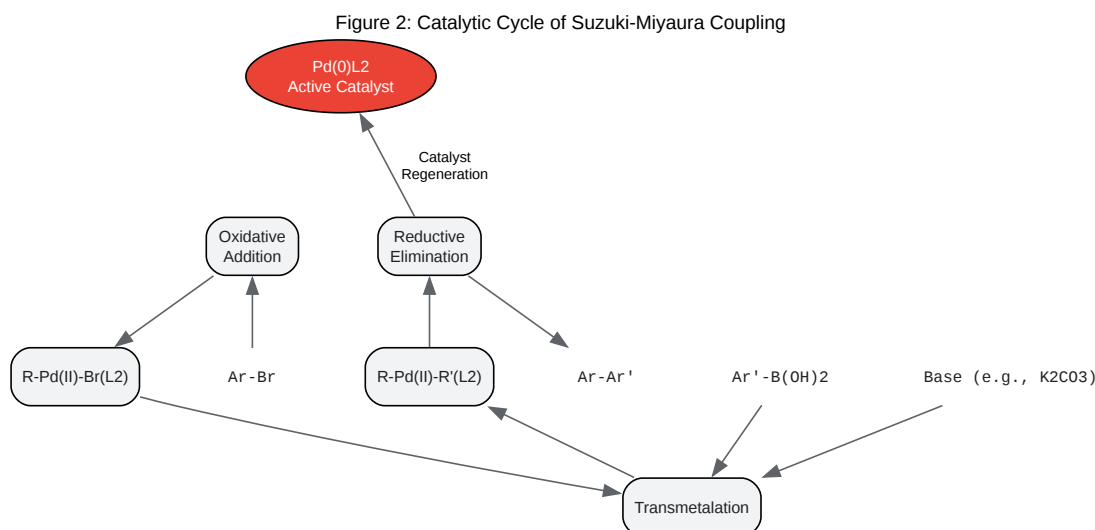

[Click to download full resolution via product page](#)

Figure 2: Catalytic Cycle of Suzuki-Miyaura Coupling.

Buchwald-Hartwig Amination

The Buchwald-Hartwig amination is a powerful palladium-catalyzed reaction for forming C-N bonds.[7] This reaction allows for the coupling of the C5-bromo position with a wide range of

primary and secondary amines, making it a cornerstone for synthesizing arylamines.[3] Given the higher reactivity of the C-Br bond, selective amination at C5 is highly feasible.[8]

Figure 3: Catalytic Cycle of Buchwald-Hartwig Amination

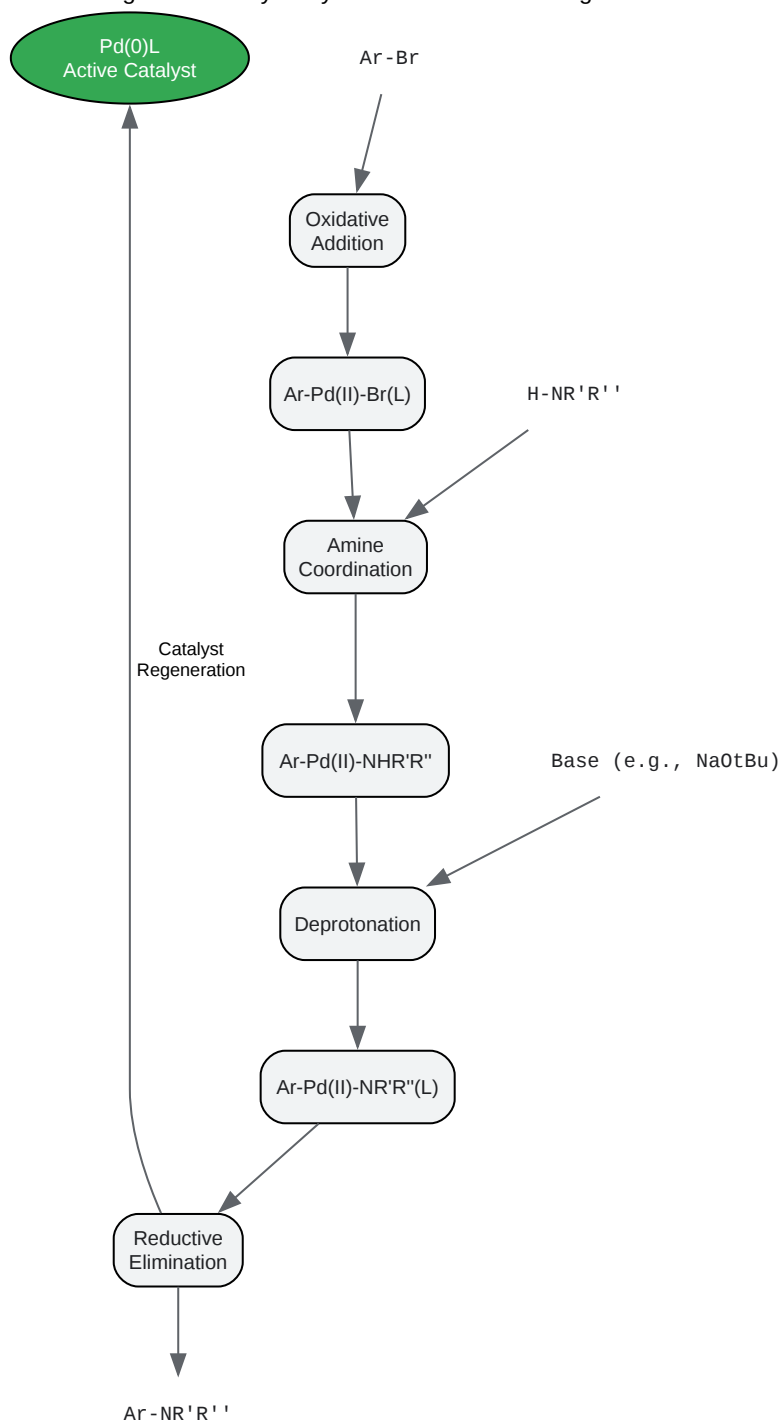

[Click to download full resolution via product page](#)

Figure 3: Catalytic Cycle of Buchwald-Hartwig Amination.

Reactivity of the Amino and Methoxy Groups

Reactions of the C4-Amino Group

The primary amino group at the C4 position is nucleophilic and can readily undergo standard amine reactions.[5]

- Acylation: Reaction with acid chlorides or anhydrides in the presence of a base will form the corresponding amides.
- Alkylation: The amino group can be alkylated, although selectivity between N-alkylation and potential reactions at the ring nitrogens may require careful condition optimization.
- Condensation: The amine can react with carbonyl compounds to form imines or participate in cyclocondensation reactions.

Reactivity of the C2-Methoxy Group

The C2-methoxy group is generally stable. However, in electron-deficient pyrimidine systems, alkoxy groups at the C2 or C4 positions can be displaced by strong nucleophiles under harsh reaction conditions (e.g., high temperatures).[9] This provides a potential secondary site for functionalization after the C5 position has been modified.

Experimental Protocols

The following are generalized protocols for key reactions, adapted from procedures for structurally similar halopyrimidines.[4][8] Optimization is likely required for **5-Bromo-2-methoxypyrimidin-4-amine**.

General Protocol for Suzuki-Miyaura Coupling

- Preparation: To a dry Schlenk flask under an inert atmosphere (e.g., Argon), add **5-Bromo-2-methoxypyrimidin-4-amine** (1.0 equiv.), the arylboronic acid (1.2-1.5 equiv.), a palladium catalyst (e.g., Pd(PPh₃)₄, 2-5 mol%), and a base (e.g., K₂CO₃ or Cs₂CO₃, 2.0-3.0 equiv.).[4]

- Solvent Addition: Add a degassed solvent system, typically a mixture of an organic solvent and water (e.g., 1,4-dioxane/water 4:1).[8]
- Reaction: Heat the reaction mixture with stirring to a temperature of 80-100 °C. Monitor reaction progress by TLC or LC-MS.[4]
- Workup: Upon completion, cool the reaction to room temperature. Dilute with an organic solvent (e.g., ethyl acetate) and wash with water and brine.
- Purification: Dry the organic layer over anhydrous sodium sulfate, filter, and concentrate under reduced pressure. Purify the crude product by flash column chromatography.

General Protocol for Buchwald-Hartwig Amination

- Preparation: To an oven-dried Schlenk flask, add the palladium precatalyst (e.g., Pd₂(dba)₃, 1-2 mol%), the phosphine ligand (e.g., XPhos, 2-4 mol%), and the base (e.g., NaOtBu, 1.4 equiv.). Seal the flask, and evacuate and backfill with an inert gas three times.[4][8]
- Reagent Addition: Add **5-Bromo-2-methoxypyrimidin-4-amine** (1.0 equiv.) and the desired amine (1.1-1.2 equiv.).[4]
- Solvent Addition: Add an anhydrous, degassed solvent (e.g., toluene or dioxane).[4]
- Reaction: Heat the reaction mixture with stirring to a temperature of 80-110 °C. Monitor the reaction progress by TLC or LC-MS.[4]
- Workup: Upon completion, cool the reaction to room temperature. Quench the reaction with a saturated aqueous solution of ammonium chloride and extract with an organic solvent.
- Purification: Wash the combined organic layers with brine, dry over anhydrous sodium sulfate, and concentrate under reduced pressure. Purify the crude product by flash column chromatography.[4]

Figure 4: General Experimental Workflow for Cross-Coupling

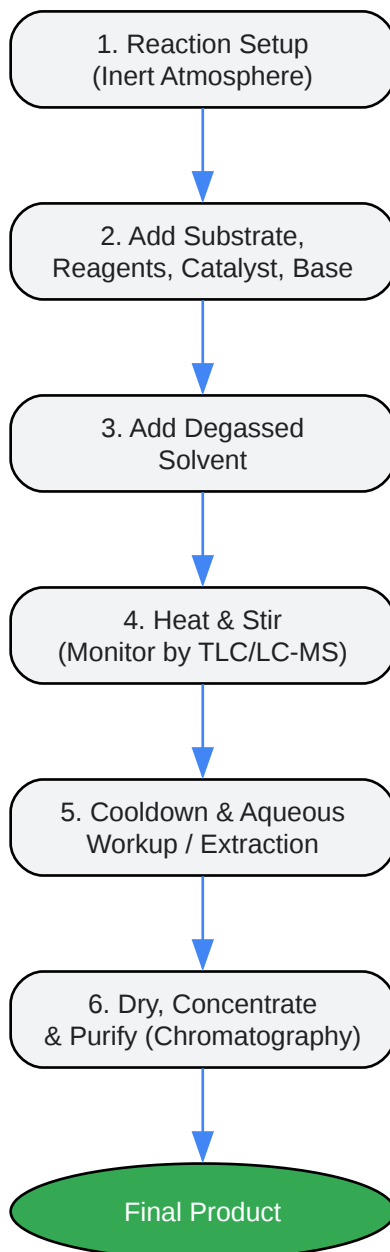

[Click to download full resolution via product page](#)

Figure 4: General Experimental Workflow for Cross-Coupling.

Quantitative Data Summary

Direct experimental data for **5-Bromo-2-methoxypyrimidin-4-amine** is not widely published. The following tables present representative data for palladium-catalyzed reactions on the closely related substrate, 5-Bromo-2-chloro-4-methoxypyrimidine, to serve as a guide for reaction optimization. The data demonstrates the high selectivity for reaction at the C5-bromo position.

Table 1: Representative Conditions for Suzuki-Miyaura Coupling of a Related Halopyrimidine (Data based on reactions with structurally similar bromo-chloro-heterocycles and should be considered a starting point for optimization)[4]

Arylboronic Acid	Catalyst System (mol%)	Base (equiv.)	Solvent	Temp (°C)	Time (h)	Approx. Yield (%) at C5
Phenylboronic acid	Pd(PPh ₃) ₄ (5)	K ₂ CO ₃ (2)	Dioxane/H ₂ O	100	12	~85-95
4-Methoxyphenylboronic acid	Pd(dppf)Cl ₂ (3)	Cs ₂ CO ₃ (2.5)	Toluene/EtOH/H ₂ O	90	10	~90
3-Pyridinylboronic acid	Pd(OAc) ₂ /SPhos (2/4)	K ₃ PO ₄ (3)	Dioxane	110	16	~75

Table 2: Representative Conditions for Buchwald-Hartwig Amination of a Related Halopyrimidine (Hypothetical data based on general reactivity; optimization is required)[8]

Amine	Catalyst System (mol%)	Base (equiv.)	Solvent	Temp (°C)	Time (h)	Approx. Yield (%) at C5
Morpholine	Pd ₂ (dba) ₃ / XPhos (2/4)	NaOtBu (1.4)	Toluene	110	24	~80-90
Aniline	Pd(OAc) ₂ / RuPhos (2/4)	Cs ₂ CO ₃ (2)	Dioxane	100	18	~70-80
Benzylamine	Pd ₂ (dba) ₃ / BuXPhos (1/2)	K ₃ PO ₄ (2)	Toluene	100	16	~85

Conclusion

5-Bromo-2-methoxypyrimidin-4-amine possesses a predictable reactivity profile dominated by the highly active C5-bromo position. This site is primed for selective functionalization through various palladium-catalyzed cross-coupling reactions, providing efficient pathways to complex substituted pyrimidines. The C4-amino group offers a secondary site for diversification through conventional amine chemistry. This guide provides the theoretical framework and practical starting points necessary for researchers to effectively utilize this versatile building block in the synthesis of novel compounds for pharmaceutical and materials science applications.

Need Custom Synthesis?

BenchChem offers custom synthesis for rare earth carbides and specific isotopic labeling.

Email: info@benchchem.com or [Request Quote Online](#).

References

- 1. bhu.ac.in [bhu.ac.in]
- 2. Pyrimidine | PPTX [slideshare.net]

- 3. [benchchem.com](#) [[benchchem.com](#)]
- 4. [benchchem.com](#) [[benchchem.com](#)]
- 5. 2-Methoxypyrimidin-5-amine|Research Chemical [[benchchem.com](#)]
- 6. Synthesis, Reactions and Medicinal Uses of Pyrimidine | Pharmaguideline [[pharmaguideline.com](#)]
- 7. [benchchem.com](#) [[benchchem.com](#)]
- 8. [benchchem.com](#) [[benchchem.com](#)]
- 9. Pyrimidines. Part II. Nucleophilic substitution reactions of ethyl 4-chloro-2-methylthiopyrimidine-5-carboxylate - Journal of the Chemical Society C: Organic (RSC Publishing) [[pubs.rsc.org](#)]
- To cite this document: BenchChem. [theoretical reactivity of 5-Bromo-2-methoxypyrimidin-4-amine]. BenchChem, [2025]. [Online PDF]. Available at: [<https://www.benchchem.com/product/b582765#theoretical-reactivity-of-5-bromo-2-methoxypyrimidin-4-amine>]

Disclaimer & Data Validity:

The information provided in this document is for Research Use Only (RUO) and is strictly not intended for diagnostic or therapeutic procedures. While BenchChem strives to provide accurate protocols, we make no warranties, express or implied, regarding the fitness of this product for every specific experimental setup.

Technical Support: The protocols provided are for reference purposes. Unsure if this reagent suits your experiment? [[Contact our Ph.D. Support Team for a compatibility check](#)]

Need Industrial/Bulk Grade? [Request Custom Synthesis Quote](#)

BenchChem

Our mission is to be the trusted global source of essential and advanced chemicals, empowering scientists and researchers to drive progress in science and industry.

Contact

Address: 3281 E Guasti Rd
Ontario, CA 91761, United States
Phone: (601) 213-4426
Email: info@benchchem.com

