

large-scale synthesis of 3-(4-Chlorophenyl)picolinic acid

Author: BenchChem Technical Support Team. **Date:** May 2026

Compound of Interest

Compound Name: 3-(4-Chlorophenyl)picolinic acid

CAS No.: 1226215-87-7

Cat. No.: B582226

[Get Quote](#)

Executive Summary

This application note details a robust, kilogram-scale protocol for the synthesis of **3-(4-chlorophenyl)picolinic acid**, a critical scaffold in the development of synthetic auxin herbicides and pyridine-based pharmaceutical intermediates.^[1]

While direct arylation of picolinic acid is chemically feasible, it often suffers from catalyst poisoning due to the free carboxylic acid moiety. To ensure high reproducibility and purity (>99.5%) suitable for GMP environments, this guide utilizes a Two-Stage Strategy:

- Suzuki-Miyaura Cross-Coupling of methyl 3-bromopicolinate with 4-chlorophenylboronic acid.^[1]
- Controlled Hydrolysis and pH-modulated crystallization to isolate the free acid.

Key Performance Indicators (KPIs):

- Overall Yield: >85% (Two steps)

- Purity: >99.5% (HPLC)
- Pd Residual: <10 ppm (after scavenging)

Retrosynthetic Analysis & Strategy

The steric hindrance at the C3 position, flanked by the picolinic ester (C2) and the ring nitrogen, requires a highly active catalyst system. We utilize a Pd(dppf)Cl₂ catalyst system which offers superior stability against protodeboronation compared to Pd(PPh₃)₄, particularly in biphasic systems.

Reaction Pathway Diagram

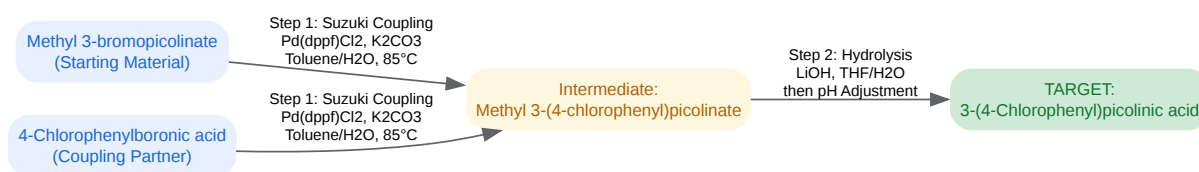

[Click to download full resolution via product page](#)

Figure 1: Two-stage synthetic pathway designed to minimize catalyst poisoning and maximize regioselectivity.

Step 1: Suzuki-Miyaura Cross-Coupling Rationale

The use of a biphasic solvent system (Toluene/Water) serves two purposes:

- Solubility: Dissolves the organic ester and the inorganic base (K₂CO₃) effectively.^[1]
- Thermal Control: Allows for efficient reflux at ~85°C, optimal for the catalytic cycle without degrading the boronic acid.

Materials & Stoichiometry

Reagent	Equiv.[1][2][3]	Role	Critical Attribute
Methyl 3-bromopicolinate	1.0	Limiting Reagent	Purity >98%
4-Chlorophenylboronic acid	1.1	Coupling Partner	Low protodeboronation rate
Pd(dppf)Cl ₂ [1] · DCM	0.02	Catalyst	2 mol% loading sufficient
K ₂ CO ₃	2.5	Base	Granular (ground)
Toluene	10 Vol	Solvent	Degassed
Water	5 Vol	Co-solvent	Deionized

Detailed Protocol

- Inertion: Charge a 5L jacketed glass reactor with Methyl 3-bromopicolinate (500 g, 2.31 mol) and 4-Chlorophenylboronic acid (397 g, 2.54 mol). Purge with N₂ for 15 minutes.
- Solvent Addition: Add degassed Toluene (5.0 L). Agitate at 200 RPM until solids are dispersed.
- Catalyst Charge: Add Pd(dppf)Cl₂ · DCM (37.7 g, 0.046 mol). Note: The solution will turn orange-red.[1]
- Base Addition: Dissolve K₂CO₃ (798 g, 5.77 mol) in Water (2.5 L) and add to the reactor.
- Reaction: Heat the biphasic mixture to 85°C internal temperature. Stir vigorously (400 RPM) to ensure phase transfer.
- Monitoring: Monitor by HPLC every 2 hours. Reaction is typically complete within 6–8 hours (<1% SM remaining).
- Workup:
 - Cool to 25°C.

- Separate phases.[1] Extract the aqueous layer with Toluene (1.0 L).
- Combine organic layers and wash with Brine (2.0 L).
- Scavenging: Treat organic layer with activated carbon (Cuno or Darco G-60) or a thiourea-functionalized silica scavenger (SiliaMetS® Thiol) at 50°C for 1 hour to remove Pd.[1]
- Filter through Celite.[1]
- Concentrate to dryness to yield the crude ester (Intermediate 1).

Step 2: Hydrolysis & Crystallization[1][4]

Rationale

Picolinic acids are zwitterionic.[1] The isolation pH is the most critical parameter.[1] If the pH is too low (<1.0), the pyridine nitrogen protonates, forming a soluble hydrochloride salt. If too high (>4.0), it remains as a carboxylate salt. The Isoelectric Point (pI) is the target for precipitation.

Detailed Protocol

- Dissolution: Dissolve the crude ester (from Step 1) in THF (2.5 L) and Water (1.0 L).
- Saponification: Add LiOH·H₂O (116 g, 2.77 mol, 1.2 equiv) slowly.
- Reaction: Stir at 40°C for 3 hours. Monitor for disappearance of ester via TLC or HPLC.
- Phase Split: Add Toluene (1.0 L) to wash non-polar impurities (unreacted boronic acid dimers). Keep the Aqueous Layer (contains product as Lithium salt).
- Acidification (Critical Step):
 - Cool aqueous layer to 5°C.[1]
 - Slowly add 6N HCl dropwise.[1]
 - Target pH: Adjust pH to 3.0 – 3.5.
 - Observation: A thick white/off-white precipitate will form.[1]

- Isolation: Stir the slurry for 2 hours at 0–5°C to maximize yield.
- Filtration: Filter the solid and wash with cold water (2 x 500 mL) followed by cold Acetone (1 x 200 mL) to remove trace water and color.
- Drying: Vacuum dry at 50°C for 12 hours.

Process Workflow Diagram

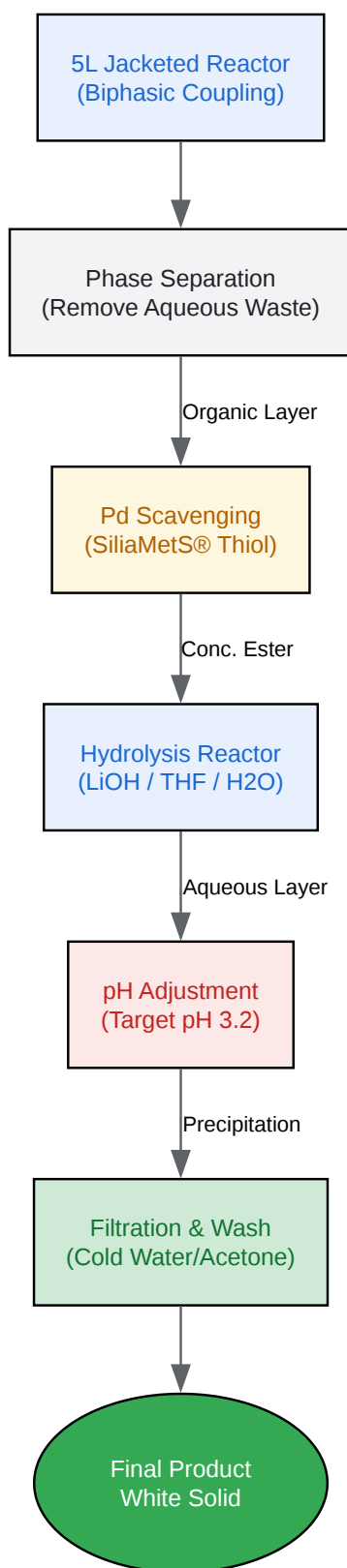

[Click to download full resolution via product page](#)

Figure 2: Unit operation workflow emphasizing phase management and purification logic.

Analytical Specifications & Troubleshooting

HPLC Method (Purity)

- Column: C18 Reverse Phase (e.g., Agilent Zorbax Eclipse Plus, 4.6 x 100mm, 3.5 μ m).
- Mobile Phase A: 0.1% H₃PO₄ in Water.[1]
- Mobile Phase B: Acetonitrile.[1]
- Gradient: 10% B to 90% B over 15 min.
- Detection: UV @ 254 nm.[1][4]
- Retention Time: Product elutes ~8.5 min; des-chloro impurity (if any) elutes earlier.

Troubleshooting Guide

Issue	Probable Cause	Corrective Action
Low Yield (Step 1)	O ₂ poisoning of Pd catalyst.[1]	Ensure rigorous N ₂ sparging of solvents before catalyst addition.
Black Precipitate	Pd precipitation ("Pd Black").	Increase ligand ratio or ensure temperature does not exceed 90°C.
Product is Sticky/Oily	pH incorrect during isolation.	Re-dissolve in base and re-precipitate strictly at pH 3.2.
High Pd Residue	Inefficient scavenging.	Use thiol-modified silica scavengers rather than just charcoal.[1]

Safety & Waste Management

- Boronic Acids: Generally low toxicity, but handle as potential irritants.
- Palladium: Heavy metal waste.[1] All aqueous streams and filter cakes containing Pd must be segregated for metal recovery.[1]

- Exotherm: The hydrolysis step (Step 2) is mildly exothermic; control addition rate of LiOH.

References

- Miyaura, N., & Suzuki, A. (1995). Palladium-Catalyzed Cross-Coupling Reactions of Organoboron Compounds. *Chemical Reviews*, 95(7), 2457–2483. [Link](#)
- Goossen, L. J., et al. (2006). Synthesis of Biaryls via Decarboxylative Coupling. *Journal of the American Chemical Society*, 128(30), 9606–9607. (Context on alternative decarboxylative routes). [Link](#)
- Li, J. J. (2014). *Name Reactions: A Collection of Detailed Mechanisms and Synthetic Applications*. Springer.[1] (Reference for Suzuki Mechanism).
- Organic Syntheses. (2011). Discussion on Picolinic Acid derivatives and purification via copper salts or pH adjustment. *Organic Syntheses, Coll.[5] Vol. 3*, p.740. [Link](#)
- Carey, J. S., et al. (2006). Analysis of the reactions used for the preparation of drug candidate molecules. *Organic & Biomolecular Chemistry*, 4, 2337-2347.[1] (Industrial relevance of Suzuki coupling). [Link](#)

Need Custom Synthesis?

BenchChem offers custom synthesis for rare earth carbides and specific isotopic labeling.

Email: info@benchchem.com or [Request Quote Online](#).

Sources

- [1. Welcome To Hyma Synthesis Pvt. Ltd \[hymasynthesis.com\]](#)
- [2. myers.faculty.chemistry.harvard.edu \[myers.faculty.chemistry.harvard.edu\]](#)
- [3. tcichemicals.com \[tcichemicals.com\]](#)
- [4. 3-Aryltetronic acids: efficient preparation and use as precursors for vulpinic acids - PubMed \[pubmed.ncbi.nlm.nih.gov\]](#)
- [5. Organic Syntheses Procedure \[orgsyn.org\]](#)

- To cite this document: BenchChem. [large-scale synthesis of 3-(4-Chlorophenyl)picolinic acid]. BenchChem, [2026]. [Online PDF]. Available at: [\[https://www.benchchem.com/product/b582226/docs#large-scale-synthesis-of-3-4-chlorophenyl-picolinic-acid\]](https://www.benchchem.com/product/b582226/docs#large-scale-synthesis-of-3-4-chlorophenyl-picolinic-acid)

Disclaimer & Data Validity:

The information provided in this document is for Research Use Only (RUO) and is strictly not intended for diagnostic or therapeutic procedures. While BenchChem strives to provide accurate protocols, we make no warranties, express or implied, regarding the fitness of this product for every specific experimental setup.

Technical Support: The protocols provided are for reference purposes. Unsure if this reagent suits your experiment?

Need Industrial/Bulk Grade? [Request Custom Synthesis Quote](#)

BenchChem

Our mission is to be the trusted global source of essential and advanced chemicals, empowering scientists and researchers to drive progress in science and industry.

Contact

Address: 3281 E Guasti Rd
Ontario, CA 91761, United States
Phone: (601) 213-4426
Email: info@benchchem.com

[Contact our Ph.D. Support Team for a compatibility check](#)