

Technical Support Center: Synthesis of Chlorotriazole Compounds

Author: BenchChem Technical Support Team. **Date:** May 2026

Compound of Interest

Compound Name: *3-(3-Chloro-1H-1,2,4-triazol-5-yl)propanoic acid*

CAS No.: 1243250-11-4

Cat. No.: B581219

[Get Quote](#)

Prepared by: Gemini, Senior Application Scientist

Welcome to the Technical Support Center for the synthesis of chlorotriazole compounds. This guide is designed for researchers, scientists, and professionals in drug development. It provides in-depth, field-proven insights into troubleshooting common challenges encountered during the synthesis of these vital heterocyclic compounds. Our goal is to move beyond simple procedural steps to explain the underlying chemical principles, empowering you to diagnose and resolve issues effectively in your own laboratory settings.

Section 1: Fundamentals of Chlorotriazole Synthesis

Chlorotriazole compounds, which incorporate a triazole ring functionalized with one or more chlorine atoms, are significant scaffolds in medicinal chemistry and materials science.[1] The most prevalent and versatile method for synthesizing the 1,2,3-triazole core is the Huisgen 1,3-dipolar cycloaddition of an azide with an alkyne.[2] The development of metal-catalyzed versions of this reaction, particularly the Copper(I)-Catalyzed Azide-Alkyne Cycloaddition

(CuAAC), has revolutionized access to these compounds, offering high yields and exceptional regioselectivity under mild conditions.^{[3][4]}

The generally accepted mechanism for the CuAAC reaction, often referred to as "click chemistry," is depicted below. Understanding this catalytic cycle is fundamental to troubleshooting many common synthesis problems.^{[5][6]}

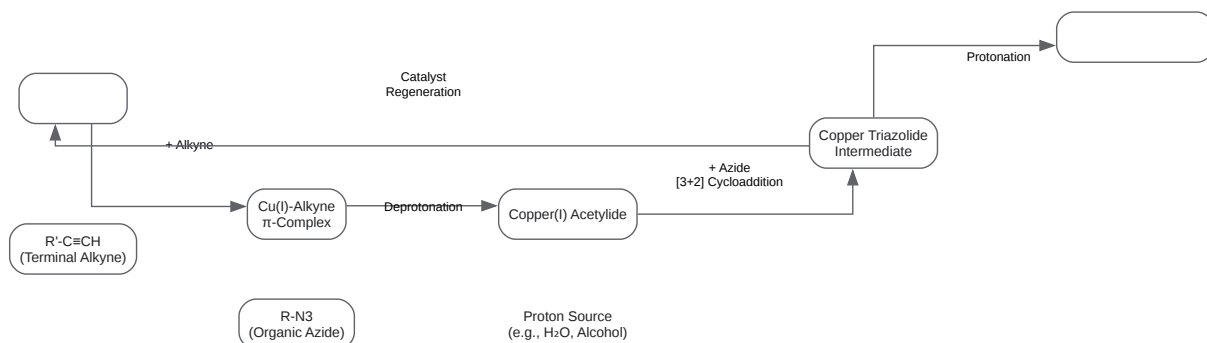
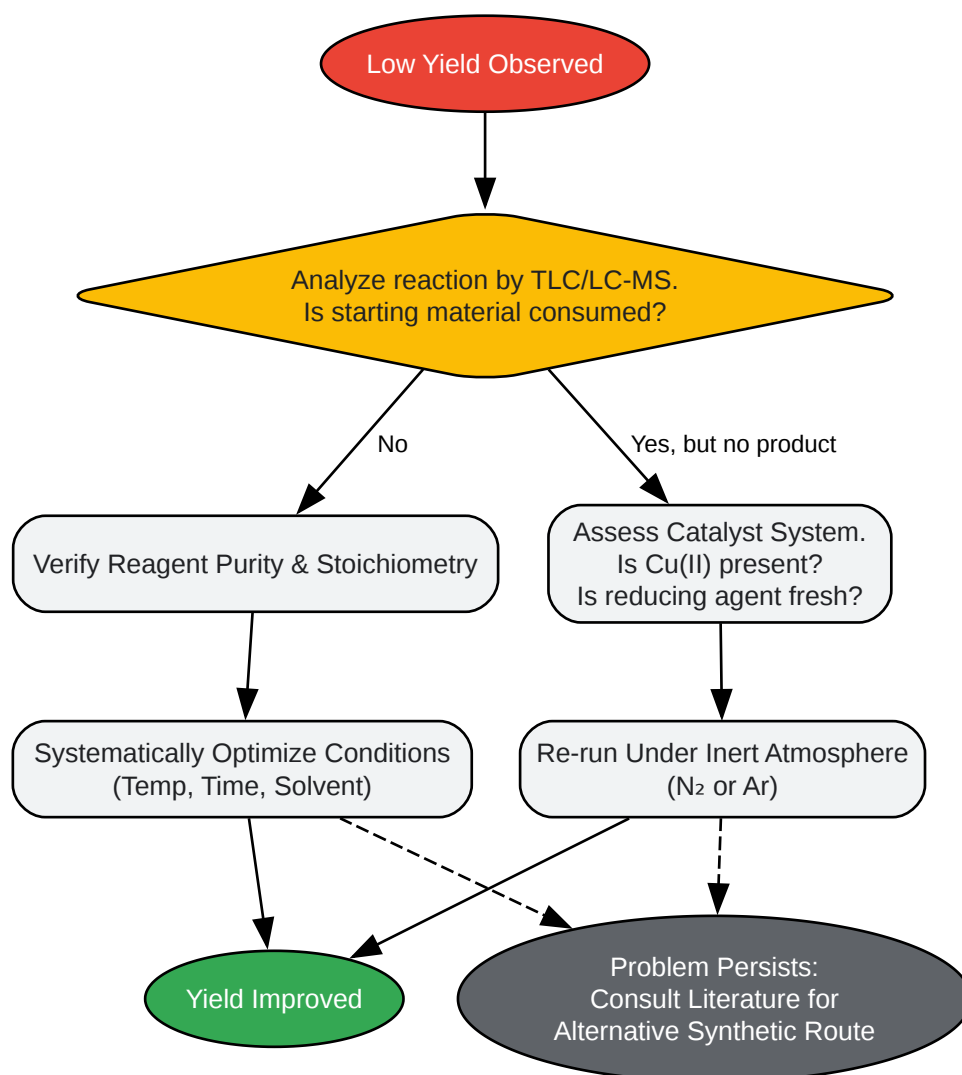

Figure 1. Simplified CuAAC Catalytic Cycle



[Click to download full resolution via product page](#)

Need Custom Synthesis?

BenchChem offers custom synthesis for rare earth carbides and specific isotopic labeling.

Email: info@benchchem.com or [Request Quote Online](#).

Sources

- 1. scispace.com [scispace.com]
- 2. researchgate.net [researchgate.net]
- 3. [1,2,3-Triazole synthesis](https://organic-chemistry.org) [organic-chemistry.org]

- [4. mdpi.com \[mdpi.com\]](https://www.mdpi.com)
- [5. Synthesis methods of 1,2,3-/1,2,4-triazoles: A review - PMC \[pmc.ncbi.nlm.nih.gov\]](https://pubmed.ncbi.nlm.nih.gov/)
- [6. Frontiers | Synthesis methods of 1,2,3-/1,2,4-triazoles: A review \[frontiersin.org\]](https://www.frontiersin.org)
- To cite this document: BenchChem. [Technical Support Center: Synthesis of Chlorotriazole Compounds]. BenchChem, [2026]. [Online PDF]. Available at: [\[https://www.benchchem.com/product/b581219/docs#technical-support-center-synthesis-of-chlorotriazole-compounds\]](https://www.benchchem.com/product/b581219/docs#technical-support-center-synthesis-of-chlorotriazole-compounds)

Disclaimer & Data Validity:

The information provided in this document is for Research Use Only (RUO) and is strictly not intended for diagnostic or therapeutic procedures. While BenchChem strives to provide accurate protocols, we make no warranties, express or implied, regarding the fitness of this product for every specific experimental setup.

Technical Support: The protocols provided are for reference purposes. Unsure if this reagent suits your experiment?

Need Industrial/Bulk Grade? [Request Custom Synthesis Quote](#)

BenchChem

Our mission is to be the trusted global source of essential and advanced chemicals, empowering scientists and researchers to drive progress in science and industry.

Contact

Address: 3281 E Guasti Rd
Ontario, CA 91761, United States
Phone: (601) 213-4426
Email: info@benchchem.com

[Contact our Ph.D. Support Team for a compatibility check](#)

