

Comparative Guide: Reactivity of 2-Methyl vs. 2-H Benzimidazole Derivatives

Author: BenchChem Technical Support Team. **Date:** May 2026

Compound of Interest

Compound Name: 1-(2-BOC-Aminoethyl)-2-methyl-1H-benzimidazole
CAS No.: 1414029-35-8
Cat. No.: B581756

[Get Quote](#)

Executive Summary: The Steric-Electronic Divergence

The choice between a 2-H and a 2-Methyl benzimidazole scaffold is rarely arbitrary; it dictates the available synthetic pathways and the physicochemical profile of the final drug candidate.

- 2-H Benzimidazole (BIM): Acts as a "Blank Slate" for transition-metal-catalyzed C–H activation. It is sterically unencumbered, allowing for facile N-functionalization, but lacks the "chemical handle" for classical condensation chemistry.
- 2-Methylbenzimidazole (2-MeBIM): Acts as a "Latent Nucleophile." The methyl group is not merely a steric blocker; it is chemically active (benzylic-like acidity), enabling lateral functionalization without transition metals. However, it introduces proximal steric strain that retards N1-substitution.

Physicochemical Profile & Acid-Base Dynamics

Understanding the ionization state is critical for predicting reactivity in both synthesis and biological media.

Table 1: Comparative Physicochemical Properties

Property	2-H Benzimidazole (BIM)	2-Methylbenzimidazole (2-MeBIM)	Implication
pKa (Conj. Acid)	~5.6	~6.1	2-Me is more basic. The +I (inductive) effect of the methyl group stabilizes the protonated N3 cation.
pKa (N-H Acidity)	~12.8	~13.0 - 13.2	2-Me is less acidic. Electron donation destabilizes the N- anion. Steric bulk also hinders deprotonation by bulky bases.
LogP (Lipophilicity)	1.32	1.6 - 1.9	2-Me increases lipophilicity, improving membrane permeability but potentially reducing aqueous solubility.
N-Nucleophilicity	High	Moderate	Steric hindrance at C2 interferes with electrophile approach to N3 and N1.

Reactivity Profiles: The Divergent Pathways

A. The C2-Position: C-H Activation vs. Lateral Functionalization

This is the most distinct difference. The substituent at C2 determines whether you use modern catalytic C–H activation or classical carbanion chemistry.

Scenario 1: The 2-H Scaffold (C-H Activation)

The C2 proton is relatively acidic (pKa ~32 in DMSO) but is best utilized via transition metal catalysis.

- Mechanism: Oxidative addition of a metal (Rh, Ni, Cu) into the C2-H bond.
- Utility: Direct arylation or alkylation without pre-functionalization (e.g., no need for 2-halo precursors).
- Key Constraint: Requires protection of N1 to prevent catalyst poisoning or competitive N-arylation.

Scenario 2: The 2-Methyl Scaffold (Lateral Activation)

The protons on the 2-methyl group are acidic (pKa ~28) due to resonance stabilization of the resulting carbanion into the aromatic ring (aza-allylic resonance).

- Mechanism: Deprotonation by strong bases (n-BuLi, NaOEt) or acid-catalyzed enamine-like reactivity.
- Utility:
 - Condensation: Reacts with aldehydes to form styrylbenzimidazoles (Knoevenagel type).
 - Oxidation: Can be oxidized to carboxylic acids (KMnO₄) or aldehydes (SeO₂).
 - Lateral Lithiation: Reacts with alkyl halides to extend the carbon chain.

B. N-Functionalization (Alkylation/Acylation)

- 2-H BIM: Reacts rapidly with alkyl halides via SN₂. Tautomerism (N1 vs N3) is degenerate in unsubstituted BIM, but relevant in 5-substituted derivatives.
- 2-Me BIM: The C2-methyl group exerts proximal steric hindrance.

- Rate: Reaction rates with bulky electrophiles (e.g., isopropyl bromide) are significantly slower compared to 2-H BIM.
- Regioselectivity: In 4-substituted systems, the 2-methyl group can amplify regiochemical preferences by mechanically blocking the adjacent nitrogen.

Visualization of Reactivity Logic

The following diagram illustrates the decision matrix for selecting a scaffold based on the desired transformation.

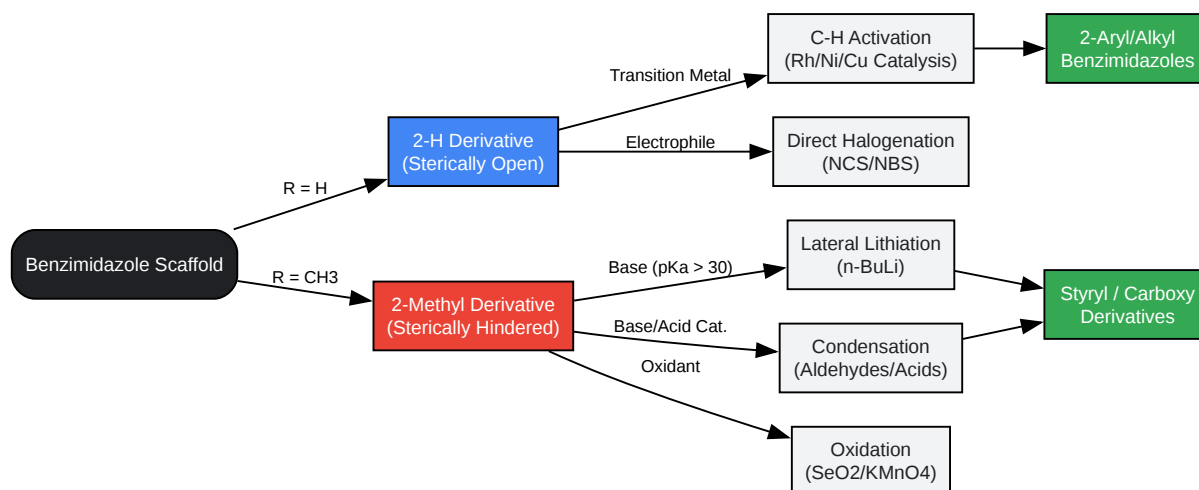

[Click to download full resolution via product page](#)

Caption: Divergent synthetic utility of 2-H vs 2-Methyl scaffolds. 2-H favors metal catalysis; 2-Me favors classical anion chemistry.

Experimental Protocols

These protocols illustrate the distinct chemistry of each derivative.

Protocol A: C2-H Activation of Benzimidazole (2-H)

Target: Direct C2-Alkylation using an alkene (Hydroalkylation). Principle: Rhodium-catalyzed insertion into the C2-H bond.

- Reagents: Benzimidazole (1.0 eq), Alkene (e.g., 3,3-dimethyl-1-butene, 1.2 eq), $[\text{RhCl}(\text{coe})_2]_2$ (5 mol%), PCy_3 (7.5 mol%), THF.
- Procedure:
 - In a glovebox, mix catalyst and ligand in THF to form the active species.
 - Add benzimidazole and the alkene.[1][2][3]
 - Heat to 150°C in a sealed pressure tube for 4-18 hours.
 - Note: The N1-H must often be protected (e.g., N-benzyl) or the reaction conditions must tolerate the free amine (Lewis acid co-catalysts like AlCl_3 are sometimes added to facilitate this).
- Outcome: Formation of 2-alkylbenzimidazole with 100% atom economy.

Protocol B: Condensation of 2-Methylbenzimidazole

Target: Synthesis of 2-Styrylbenzimidazole. Principle: Acidic activation of the methyl protons (Anion/Enamine mechanism).

- Reagents: 2-Methylbenzimidazole (1.0 eq), Benzaldehyde (1.0 eq), Acetic Anhydride (excess) or Piperidine (cat.) in Ethanol.
- Procedure (Acidic Method):
 - Dissolve 2-MeBIM and benzaldehyde in acetic anhydride.
 - Reflux for 4-6 hours. The Ac_2O serves as both solvent and dehydrating agent.
 - Pour onto crushed ice/water. Neutralize with NH_4OH . [4]
 - Filter the precipitate (Styryl product).

- Mechanism: The methyl group deprotonates to form an enamine-type intermediate which attacks the aldehyde carbonyl.
- Outcome: High yield (>80%) of the conjugated alkene system. This reaction is impossible with 2-H benzimidazole.

References

- Bhandari, D., et al. (2021). "An Overview About Synthetic and Biological Profile of Benzimidazole." Scholars Research Library.
- Kishore Babu, P.N., et al. (2011). "Ultrasound Promoted Simple and Efficient N-Alkylation of 2-Substituted Benzimidazoles." Asian Journal of Chemistry.
- Knippel, J.L., et al. (2022).[3] "Enantioselective C2-Allylation of Benzimidazoles Using 1,3-Diene Pronucleophiles." Organic Letters.
- Hansen, J.H., & Fjellaksel, R. (2019). "Catalytic Intermolecular Functionalization of Benzimidazoles." IntechOpen.
- Saini, R., et al. (2016). "Synthesis and Antioxidant Activity of 2-Methyl Benzimidazole." Journal of Drug Delivery & Therapeutics.
- Zhang, S. (2012). "A Reliable and Efficient First Principles-Based Method for Predicting pKa Values." Journal of Computational Chemistry.

Need Custom Synthesis?

BenchChem offers custom synthesis for rare earth carbides and specific isotopic labeling.

Email: info@benchchem.com or [Request Quote Online](#).

Sources

- [1. researchgate.net \[researchgate.net\]](https://www.researchgate.net)
- [2. C2-Selective Branched Alkylation of Benzimidazoles by Rhodium\(I\)-catalyzed C–H Activation - PMC \[pmc.ncbi.nlm.nih.gov\]](https://pubmed.ncbi.nlm.nih.gov/21584811/)

- [3. dspace.mit.edu \[dspace.mit.edu\]](https://dspace.mit.edu)
- [4. srrjournals.com \[srrjournals.com\]](https://srrjournals.com)
- To cite this document: BenchChem. [Comparative Guide: Reactivity of 2-Methyl vs. 2-H Benzimidazole Derivatives]. BenchChem, [2026]. [Online PDF]. Available at: [\[https://www.benchchem.com/product/b581756/docs#comparative-guide-reactivity-of-2-methyl-vs-2-h-benzimidazole-derivatives\]](https://www.benchchem.com/product/b581756/docs#comparative-guide-reactivity-of-2-methyl-vs-2-h-benzimidazole-derivatives)

Disclaimer & Data Validity:

The information provided in this document is for Research Use Only (RUO) and is strictly not intended for diagnostic or therapeutic procedures. While BenchChem strives to provide accurate protocols, we make no warranties, express or implied, regarding the fitness of this product for every specific experimental setup.

Technical Support: The protocols provided are for reference purposes. Unsure if this reagent suits your experiment?

Need Industrial/Bulk Grade? [Request Custom Synthesis Quote](#)

BenchChem

Our mission is to be the trusted global source of essential and advanced chemicals, empowering scientists and researchers to drive progress in science and industry.

Contact

Address: 3281 E Guasti Rd
Ontario, CA 91761, United States
Phone: (601) 213-4426
Email: info@benchchem.com

[Contact our Ph.D. Support Team for a compatibility check](#)