

Technical Support Center: Overcoming Challenges in D-Alanine Sofosbuvir Solid-State Characterization

Author: BenchChem Technical Support Team. **Date:** May 2026

Compound of Interest

Compound Name: *D-Alanine Sofosbuvir*

CAS No.: 1064684-71-4

Cat. No.: B580185

[Get Quote](#)

Welcome to the technical support center for the solid-state characterization of **D-Alanine Sofosbuvir**. This guide is designed for researchers, scientists, and drug development professionals to navigate the complexities associated with the solid-state properties of this active pharmaceutical ingredient (API). **D-Alanine Sofosbuvir**, a prodrug of the potent antiviral agent Sofosbuvir, presents unique challenges in its solid-state analysis due to its potential for polymorphism, complex degradation pathways, and interactions with moisture.[\[1\]](#)[\[2\]](#)[\[3\]](#)

This resource provides in-depth troubleshooting guides and frequently asked questions (FAQs) to address specific issues you may encounter during your experiments. The information herein is structured to provide not just procedural steps, but also the scientific rationale behind them, empowering you to make informed decisions in your analytical workflows.

I. Troubleshooting Guides for Key Analytical Techniques

The solid-state form of an API can significantly impact its stability, solubility, and bioavailability. [4][5] Therefore, thorough characterization is a critical aspect of drug development. Below are troubleshooting guides for common analytical techniques used in solid-state characterization.

Powder X-ray Diffraction (PXRD) Troubleshooting

PXRD is a cornerstone technique for identifying crystalline phases and assessing the degree of crystallinity.[6][7] However, issues such as peak broadening, shifting, and the appearance of unexpected peaks can complicate data interpretation.

Observed Problem	Potential Causes	Recommended Solutions & Rationale
<p>Broad, ill-defined peaks (amorphous halo)</p>	<p>1. Presence of amorphous content.[4] 2. Small crystallite size. 3. Sample preparation issues (e.g., excessive grinding).[8]</p>	<p>1. Quantify amorphous content: Use complementary techniques like DSC to look for a glass transition or DVS to assess moisture sorption, which is often higher for amorphous materials.[9][10] 2. Optimize crystallization: Re-evaluate crystallization conditions (solvent, temperature, cooling rate) to promote the growth of larger crystals. 3. Gentle sample preparation: Use gentle trituration instead of aggressive grinding to prepare the sample for analysis to avoid inducing amorphization. [8]</p>
<p>Unexpected peaks in the diffractogram</p>	<p>1. Presence of a polymorphic form or a solvate/hydrate.[11] 2. Contamination with another crystalline substance. 3. Changes in the solid form during sample preparation or analysis.</p>	<p>1. Polymorph screening: Conduct a thorough polymorph screen under various conditions. Compare the experimental pattern with reference patterns if available. [12] 2. Purity check: Use a secondary technique like HPLC to verify the chemical purity of the sample.[13] 3. In-situ analysis: If available, use a variable temperature/humidity stage for the PXRD to investigate phase transitions under non-ambient conditions.</p>

Peak shifting or changes in relative intensities

1. Preferred orientation of crystallites.[6] 2. Sample displacement from the focusing circle. 3. Presence of a solid solution.

1. Reduce preferred orientation: Use a top-loading sample holder or gently pack the sample to randomize crystal orientation.[8] 2. Ensure proper sample height: Calibrate the instrument and carefully prepare the sample to ensure it is level with the sample holder. 3. Further characterization: If a solid solution is suspected, techniques like solid-state NMR can provide insights into the molecular-level environment.[14][15]

Differential Scanning Calorimetry (DSC) Troubleshooting

DSC is a powerful tool for investigating thermal transitions such as melting, crystallization, and glass transitions.[16][17] Interpreting complex thermograms for a molecule like **D-Alanine Sofosbuvir** requires careful consideration of potential overlapping events.

Observed Problem	Potential Causes	Recommended Solutions & Rationale
Broad or multiple endotherms	<ol style="list-style-type: none"> 1. Presence of multiple polymorphic forms with close melting points.[11] 2. Sample impurity. 3. Dehydration or desolvation event preceding melting. 	<ol style="list-style-type: none"> 1. Modulated DSC (MDSC): Utilize MDSC to separate reversing and non-reversing thermal events, which can help distinguish melting from other processes.[10][18] 2. Purity analysis: Employ techniques like HPLC to assess chemical purity. DSC can also be used for purity determination by analyzing the melting peak shape. 3. Correlate with TGA: Run a simultaneous Thermogravimetric Analysis (TGA) to identify any mass loss associated with the endothermic events.
No observable glass transition (T _g) for a suspected amorphous sample	<ol style="list-style-type: none"> 1. The T_g is masked by another thermal event (e.g., an enthalpy relaxation or dehydration).[9] 2. The amount of amorphous content is below the detection limit of the instrument.[19] 3. The T_g is very broad or weak. 	<ol style="list-style-type: none"> 1. MDSC: Use MDSC to deconvolve the reversing heat capacity signal from the non-reversing kinetic events.[18] 2. Increase sample size: If possible, use a larger sample mass to enhance the signal. 3. Optimize heating rate: A faster heating rate can sometimes make the T_g more prominent. Conversely, a slower rate can improve resolution.
Exotherm observed before melting	<ol style="list-style-type: none"> 1. Cold crystallization of an amorphous fraction.[4] 2. Polymorphic transition from a metastable to a more stable 	<ol style="list-style-type: none"> 1. Heating-cooling-heating cycle: Perform a cycle where the sample is heated above the exotherm, cooled rapidly, and then reheated. The

form. 3. Degradation of the sample.

absence of the exotherm on the second heat can confirm it was a crystallization event.[20]

2. Hot-stage microscopy or variable temperature PXRD: Visually observe the sample or collect PXRD patterns during heating to identify changes in the crystalline form. 3. TGA-MS/FTIR: Couple TGA with a mass spectrometer or FTIR to analyze any evolved gases, which can indicate decomposition.

Dynamic Vapor Sorption (DVS) Troubleshooting

DVS is crucial for understanding the hygroscopicity of a material and its propensity to form hydrates.[21][22] The interaction of **D-Alanine Sofosbuvir** with water vapor can trigger phase transformations that need to be carefully monitored.

Observed Problem	Potential Causes	Recommended Solutions & Rationale
Hysteresis in the sorption/desorption isotherm	<ol style="list-style-type: none"> 1. Formation of a hydrate at high relative humidity (RH).[22] 2. Capillary condensation in a porous material. 3. Irreversible change in the solid state. 	<ol style="list-style-type: none"> 1. Post-DVS characterization: Analyze the sample by PXRD after the DVS experiment to check for any changes in the crystalline form. 2. Surface area analysis: Use techniques like BET to determine the surface area and porosity of the material. 3. Isothermal holds: Program longer equilibration times at each RH step to ensure true equilibrium is reached.
Sharp weight gain at a specific RH	<ol style="list-style-type: none"> 1. Deliquescence (dissolution in absorbed water). 2. Phase transition to a hydrate form. [23] 	<ol style="list-style-type: none"> 1. Visual inspection: Observe the sample during the experiment if a camera is available. Deliquescence will result in a visible change from a solid to a liquid. 2. Combined DVS-Raman/PXRD: If available, use instrumentation that combines DVS with spectroscopic or diffraction techniques to monitor solid-state changes in real-time.
Poor reproducibility of isotherms	<ol style="list-style-type: none"> 1. Incomplete drying of the sample before the experiment. 2. Static electricity effects on the microbalance. 3. Sample size and morphology variations.[24] 	<ol style="list-style-type: none"> 1. Standardized pre-heating/drying: Implement a consistent and thorough drying step at the beginning of each DVS run. 2. Anti-static measures: Use an anti-static gun or ensure the DVS chamber is properly grounded. 3. Consistent sample

preparation: Use a consistent sample mass and try to maintain a similar particle size distribution between runs.

II. Frequently Asked Questions (FAQs)

This section addresses common questions and broader challenges related to the solid-state characterization of **D-Alanine Sofosbuvir**.

Q1: My PXRD pattern for **D-Alanine Sofosbuvir** shows a high amorphous background. How can I quantify the amorphous content?

A1: Quantifying amorphous content, especially at low levels, can be challenging. A multi-technique approach is often necessary.[\[25\]](#)

- DSC: The magnitude of the change in heat capacity (ΔC_p) at the glass transition (T_g) is directly proportional to the amount of amorphous material present.[\[9\]](#)[\[19\]](#) You will need a 100% amorphous standard of **D-Alanine Sofosbuvir** to create a calibration curve.
- DVS: Amorphous materials typically absorb more water than their crystalline counterparts. [\[10\]](#) By comparing the water uptake of your sample to that of a fully crystalline standard, you can estimate the amorphous content.
- Solid-State NMR (ssNMR): ssNMR is an inherently quantitative technique that can distinguish between crystalline and amorphous forms without the need for a standard curve in some cases.[\[26\]](#)[\[27\]](#)

Q2: I have identified two different crystalline forms of **D-Alanine Sofosbuvir**. How do I determine their thermodynamic relationship (monotropic vs. enantiotropic)?

A2: Understanding the thermodynamic relationship between polymorphs is crucial for selecting the most stable form for development.[\[11\]](#)

- Heat of Fusion Rule (Burger and Ramberger): If the higher melting polymorph has a lower heat of fusion, the relationship is enantiotropic. If it has a higher heat of fusion, the

relationship is monotropic. This requires accurate determination of melting points and heats of fusion by DSC.

- **Solubility Studies:** The more stable polymorph will have lower solubility at a given temperature. By measuring the solubility of each form as a function of temperature, you can determine if there is a transition temperature where the stability order inverts (enantiotropic relationship).
- **Slurry Conversion:** Suspending a mixture of the two forms in a solvent and monitoring the solid form over time can reveal which form is more stable under those conditions. The less stable form will dissolve and recrystallize as the more stable form.

Q3: During stability testing of a **D-Alanine Sofosbuvir** formulation, I observed a change in the PXRD pattern. What could be the cause?

A3: A change in the PXRD pattern during stability studies is a significant concern and could be due to several factors.[\[5\]](#)[\[7\]](#)

- **Polymorphic Transformation:** The initial solid form may be metastable and could be converting to a more stable polymorph over time, especially under stress conditions like elevated temperature and humidity.[\[5\]](#)
- **Hydrate/Solvate Formation:** If the formulation is exposed to moisture or residual solvent, the API could convert to a hydrate or solvate form.
- **Interaction with Excipients:** The API may be interacting with one or more of the excipients in the formulation, leading to the formation of a new solid phase.
- **Crystallization of Amorphous API:** If the initial API was amorphous, it might crystallize over time.[\[6\]](#)

To investigate this, you should characterize the transformed solid form using a range of techniques (PXRD, DSC, TGA, ssNMR) and also analyze the formulation for any chemical degradation products using HPLC.[\[13\]](#)[\[28\]](#)[\[29\]](#)

Q4: What is the role of solid-state NMR (ssNMR) in characterizing **D-Alanine Sofosbuvir**, and when should I consider using it?

A4: ssNMR is a powerful, non-destructive technique that provides information about the local chemical environment of atoms in the solid state.[30] It is particularly useful when other techniques provide ambiguous results.

- Polymorph Identification: ssNMR can clearly differentiate between polymorphs because the different crystal packing arrangements result in distinct chemical shifts.[14][15]
- Quantification: It can be used to quantify mixtures of polymorphs or the amount of amorphous content in a crystalline sample.[26]
- Drug-Excipient Interactions: ssNMR can detect interactions between the API and excipients in a formulation by observing changes in the NMR spectra.[26]
- Characterizing Amorphous Dispersions: It can provide insights into the miscibility and homogeneity of the API within a polymer matrix in amorphous solid dispersions.

Consider using ssNMR when you need to definitively identify or quantify solid forms in a complex mixture, or when you need to understand molecular-level interactions within your formulation.

III. Experimental Workflows and Diagrams

To aid in your experimental design, the following section provides a generalized workflow for solid-state characterization and a decision-making diagram for troubleshooting unexpected PXRD results.

Generalized Solid-State Characterization Workflow

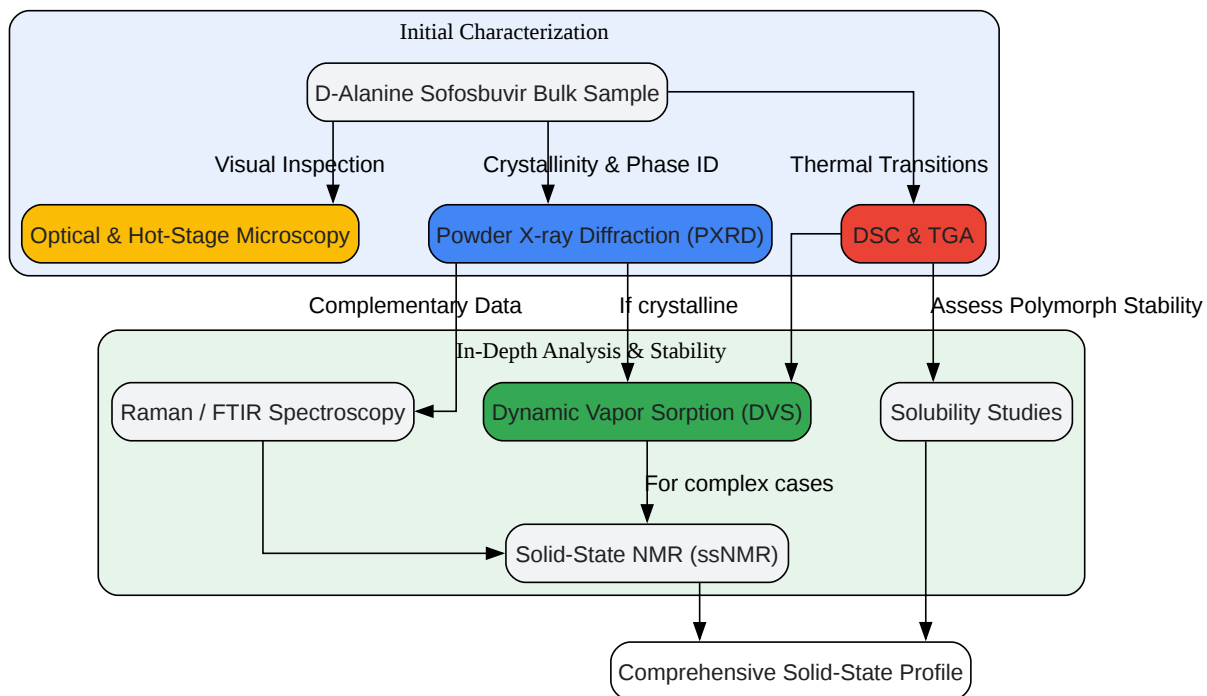

[Click to download full resolution via product page](#)

Caption: A typical workflow for the solid-state characterization of an API.

Troubleshooting Unexpected PXRD Results

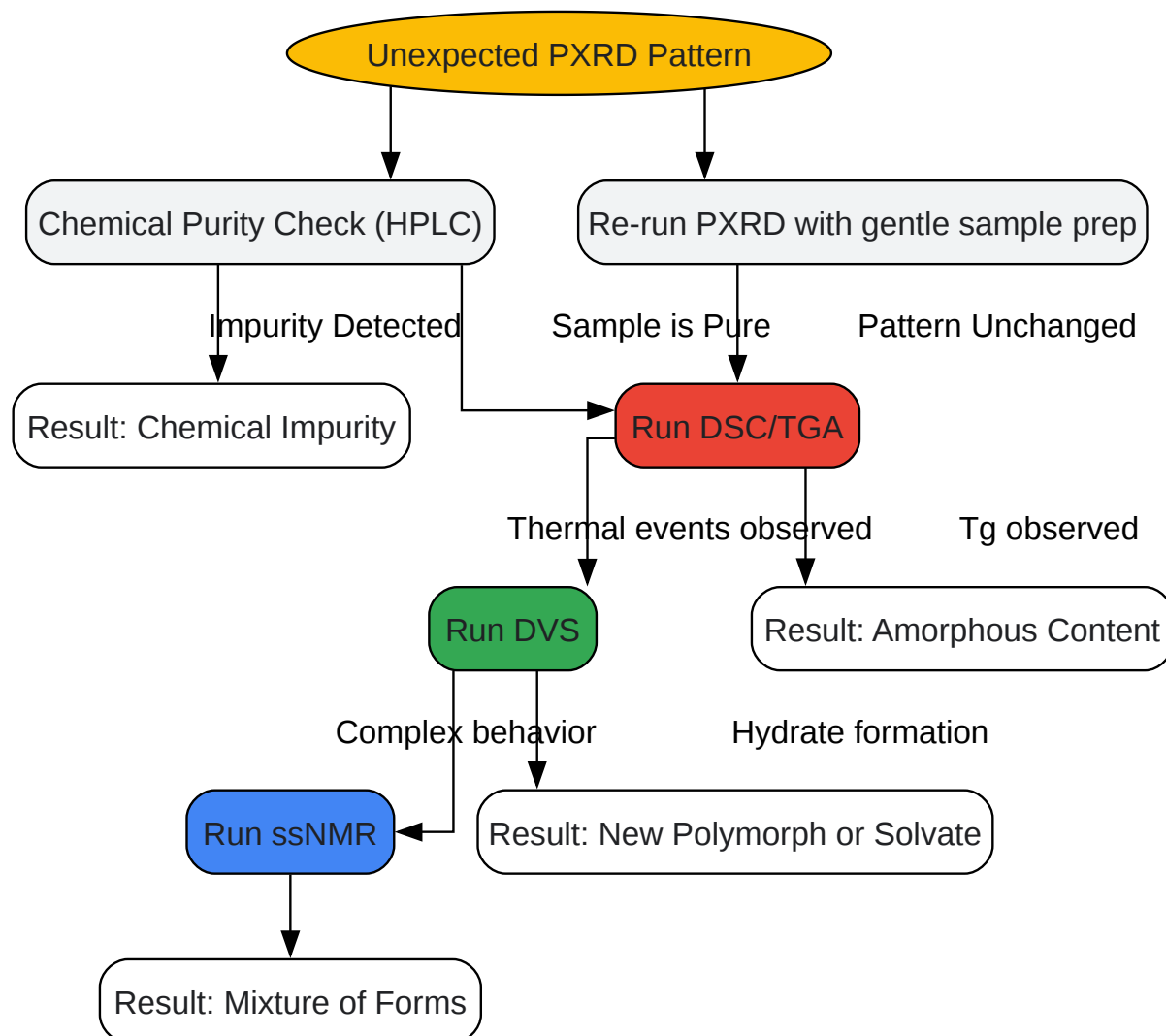

[Click to download full resolution via product page](#)

Caption: A decision tree for troubleshooting unexpected PXRD results.

IV. References

- JEOL Ltd. Differentiation of pharmaceutical polymorphs by solid-state NMR. JEOL Applications Notes. Available from:
- Surface Measurement Systems Ltd. Moisture Sorption Properties of Pharmaceutical Materials Studied by DVS. Available from:

- Pharmaceutical Technology. Solid-State Nuclear Magnetic Resonance Spectroscopy for Analyzing Polymorphic Drug Forms and Formulations. Available from:
- IUCR. Conformational Polymorphism in Sofosbuvir: Some Structural insights. 2017. Available from:
- European Pharmaceutical Review. Solid-state NMR spectroscopy of drug substances and drug products. 2020. Available from:
- MDPI. Applications of Solid-State NMR to Pharmaceutical Polymorphism and Related Matters. 2025. Available from:
- Bruker. Solid-State NMR | Characterizing Polymorphs and Amorphous Form. Available from:
- Ardena. Q&A with Ardena Experts Dynamic Vapor Sorption (DVS) and its relevance in API characterization. Available from:
- Surface Measurement Systems. Enhancing pharmaceutical development with dynamic vapor sorption (DVS) technology. 2024. Available from:
- NETZSCH Analyzing & Testing. API Characterization. Available from:
- Crystalline Cloud. Applications of Dynamic Moisture Adsorption in Crystal Research. Available from:
- American Pharmaceutical Review. The Use of Dynamic Vapor Sorption Method in the Determination of Water Sorption Limit and Setting Specification for Drug Substance. 2011. Available from:
- AlfatestLab. API: solid state robust characterization in key to cut costs and time! Available from:
- ResearchGate. Characterization of crystalline and amorphous content in pharmaceutical solids by dielectric thermal analysis. 2025. Available from:
- TA Instruments. Detection and Quantification of Amorphous Content in Pharmaceutical Materials. Available from:

- TA Instruments. Detection and Quantification of Amorphous Content in Pharmaceutical Materials. Available from:
- Agno Pharmaceuticals. Drug Substance Solid State Characterization. Available from:
- CD Formulation. Solid State Characterization of APIs. Available from:
- NCBI Bookshelf. Sofosbuvir Therapy and IFNL4 Genotype - Medical Genetics Summaries. 2017. Available from:
- PubMed. The detection of amorphous material in a nominally crystalline drug using modulated temperature DSC--a case study. 1999. Available from:
- NIH. Methods of Thermal Analysis as Fast and Reliable Tools for Identification and Quantification of Active Ingredients in Commercially Available Drug Products. Available from:
- YouTube. Characterization of Amorphous Pharmaceuticals by DSC Analysis. 2017. Available from:
- NIH. Sofosbuvir Polymorphs Distinguished by Linearly and Circularly Polarized Raman Microscopy. Available from:
- Dovepress. Changing the face of hepatitis C management – the design and development of sofosbuvir. Available from:
- Google Patents. WO2018078536A1 - Stable solid dispersion of sofosbuvir and process for preparation thereof. Available from:
- American Pharmaceutical Review. XRD in Pharmaceutical Analysis: A Versatile Tool for Problem-Solving. 2010. Available from:
- ScienceDirect. Analytical Profiling of Sofosbuvir as NS5B Protein Inhibitor for Oral Drug Delivery: Method development and Validation. 2023. Available from:
- Improved Pharma. Seeing Solids Clearly—Beyond Powder Patterns with Single-Crystal X-ray Diffraction for Polymorphs, Hydrates, and IP Confidence: How Improved Pharma Uses SCXRD. 2025. Available from:

- Malvern Panalytical. XRD Solution for Pharmaceutical Powder Analysis: Characterizing Solid Drugs with Aeris X-ray Diffractometer (XRD). 2025. Available from:
- Intertek. GMP X-Ray Powder Diffraction Pharmaceutical Analysis. Available from:
- ResearchGate. Stability studies for Sofosbuvir and Ledipasvir. Available from:
- IJBPAS. AN OUTLOOK FOR SAMPLE PREPARATION IN XRD ANALYSIS OF PHARMACEUTICAL SOLIDS. 2021. Available from:
- ResearchGate. Stability data of sofosbuvir and velpatasvir. Available from:
- International Journal of Pharmaceutical Sciences Review and Research. Validated Stability Indicating Method for Simultaneous Estimation of Velpatasvir and Sofosbuvir RP-UPLC. 2018. Available from:
- Daicel Pharma Standards. Sofosbuvir Impurities Manufacturers & Suppliers. Available from:

Need Custom Synthesis?

BenchChem offers custom synthesis for rare earth carbides and specific isotopic labeling.

Email: info@benchchem.com or [Request Quote Online](#).

Sources

- [1. Sofosbuvir Therapy and IFNL4 Genotype - Medical Genetics Summaries - NCBI Bookshelf \[ncbi.nlm.nih.gov\]](#)
- [2. Changing the face of hepatitis C management – the design and development of sofosbuvir - PMC \[pmc.ncbi.nlm.nih.gov\]](#)
- [3. Sofosbuvir Impurities Manufacturers & Suppliers - Daicel Pharma Standards \[daicelpharmastandards.com\]](#)
- [4. alfatestlab.com \[alfatestlab.com\]](#)
- [5. agnopharma.com \[agnopharma.com\]](#)
- [6. americanpharmaceuticalreview.com \[americanpharmaceuticalreview.com\]](#)
- [7. GMP X-Ray Powder Diffraction Pharmaceutical Analysis \[intertek.com\]](#)

- [8. ijbpas.com \[ijbpas.com\]](#)
- [9. Detection and Quantification of Amorphous Content in Pharmaceutical Materials - TA Instruments \[tainstruments.com\]](#)
- [10. The detection of amorphous material in a nominally crystalline drug using modulated temperature DSC--a case study - PubMed \[pubmed.ncbi.nlm.nih.gov\]](#)
- [11. iucr2017.org \[iucr2017.org\]](#)
- [12. Sofosbuvir Polymorphs Distinguished by Linearly and Circularly Polarized Raman Microscopy - PMC \[pmc.ncbi.nlm.nih.gov\]](#)
- [13. researchgate.net \[researchgate.net\]](#)
- [14. Differentiation of pharmaceutical polymorphs by solid-state NMR | Applications Notes | JEOL Ltd. \[jeol.com\]](#)
- [15. europeanpharmaceuticalreview.com \[europeanpharmaceuticalreview.com\]](#)
- [16. analyzing-testing.netzsch.com \[analyzing-testing.netzsch.com\]](#)
- [17. Methods of Thermal Analysis as Fast and Reliable Tools for Identification and Quantification of Active Ingredients in Commercially Available Drug Products - PMC \[pmc.ncbi.nlm.nih.gov\]](#)
- [18. tainstruments.com \[tainstruments.com\]](#)
- [19. youtube.com \[youtube.com\]](#)
- [20. researchgate.net \[researchgate.net\]](#)
- [21. public.jenck.com \[public.jenck.com\]](#)
- [22. ardena.com \[ardena.com\]](#)
- [23. news-medical.net \[news-medical.net\]](#)
- [24. americanpharmaceuticalreview.com \[americanpharmaceuticalreview.com\]](#)
- [25. Solid State Characterization of APIs - CD Formulation \[formulationbio.com\]](#)
- [26. pharmtech.com \[pharmtech.com\]](#)
- [27. Solid-State NMR | Characterizing Polymorphs and Amorphous Form | Bruker \[bruker.com\]](#)
- [28. researchgate.net \[researchgate.net\]](#)
- [29. globalresearchonline.net \[globalresearchonline.net\]](#)
- [30. researchgate.net \[researchgate.net\]](#)

- To cite this document: BenchChem. [Technical Support Center: Overcoming Challenges in D-Alanine Sofosbuvir Solid-State Characterization]. BenchChem, [2026]. [Online PDF]. Available at: [<https://www.benchchem.com/product/b580185/docs#technical-support-center-overcoming-challenges-in-d-alanine-sofosbuvir-solid-state-characterization>]

Disclaimer & Data Validity:

The information provided in this document is for Research Use Only (RUO) and is strictly not intended for diagnostic or therapeutic procedures. While BenchChem strives to provide accurate protocols, we make no warranties, express or implied, regarding the fitness of this product for every specific experimental setup.

Technical Support: The protocols provided are for reference purposes. Unsure if this reagent suits your experiment?

Need Industrial/Bulk Grade? [Request Custom Synthesis Quote](#)

BenchChem

Our mission is to be the trusted global source of essential and advanced chemicals, empowering scientists and researchers to drive progress in science and industry.

Contact

Address: 3281 E Guasti Rd
Ontario, CA 91761, United States
Phone: (601) 213-4426
Email: info@benchchem.com

[Contact our Ph.D. Support Team for a compatibility check](#)