

Technical Guide: Spectroscopic Profiling of 4'-Bromoacetophenone-d7

Author: BenchChem Technical Support Team. **Date:** May 2026

Compound of Interest

Compound Name: 4'-BROMOACETOPHENONE-D7

CAS No.: 1219805-88-5

Cat. No.: B580897

[Get Quote](#)

Executive Summary

4'-Bromoacetophenone-d7 (Perdeuterated 4'-Bromoacetophenone) represents a critical internal standard (IS) in the quantitative analysis of halogenated aromatic ketones. Its utility spans from metabolic stability studies to environmental forensic analysis of pharmaceutical intermediates.

This guide provides a definitive technical reference for the spectroscopic characterization of this isotopologue. Unlike its non-deuterated parent (CAS 99-90-1), the d7-variant exhibits unique spectral signatures driven by the Deuterium Isotope Effect, necessitating specialized interpretation of NMR coupling constants (

), IR frequency shifts (

), and Mass Spectrometry fragmentation patterns.

Part 1: Chemical Identity & Isotopic Architecture

The complete deuteration of the molecule (d7) implies the substitution of all seven hydrogen atoms (4 aromatic, 3 aliphatic) with deuterium (

H). This results in a mass shift of +7 Da, sufficient to avoid isobaric interference with the analyte in LC-MS/MS assays.

Parameter	Data	Notes
Compound Name	4'-Bromoacetophenone-d7	Also: 1-(4-Bromophenyl)ethanone-d7
CAS Number	1219805-88-5	Commercial assignment; Reference parent CAS 99-90-1
Chemical Formula		
Molecular Weight	206.09 g/mol	vs. 199.04 g/mol (non-deuterated)
Isotopic Enrichment	atom % D	Critical for "silent" H NMR baseline
Appearance	White to off-white solid	MP: 50–52 °C (Similar to parent)

Part 2: Mass Spectrometry (MS) Profiling

Mass Spectrometry is the primary validation tool for this compound. The presence of Bromine (

Br and

Br) creates a characteristic 1:1 isotopic doublet, which is preserved in the deuterated analog but shifted by the mass of the deuterium atoms.

The Isotopic Mass Shift

In Electron Ionization (EI) or ESI+, the molecular ion (

or

) shifts significantly.

- Parent (d0): Base peaks at m/z 198 (

Br) and 200 (

Br).

- Isotopologue (d7): Base peaks at m/z 205 (

Br) and 207 (

Br).

Fragmentation Logic (EI-MS)

The fragmentation follows the standard ketone "alpha-cleavage" rules but reveals the location of deuterium labels.

- Loss of Methyl Group:
 - d0: Loss of
(15 Da)
Acylium ion (
183/185).
 - d7: Loss of
(18 Da)
Acylium ion (
187/189).
 - Diagnostic Value: Confirms deuteration of the acetyl tail.
- Loss of Acetyl Group:
 - d0: Loss of
(43 Da)
Phenyl cation (

155/157).

- d7: Loss of

(46 Da)

Phenyl cation-d4 (

159/161).

- Diagnostic Value: Confirms deuteration of the aromatic ring.

Visualization: MS Fragmentation Pathway

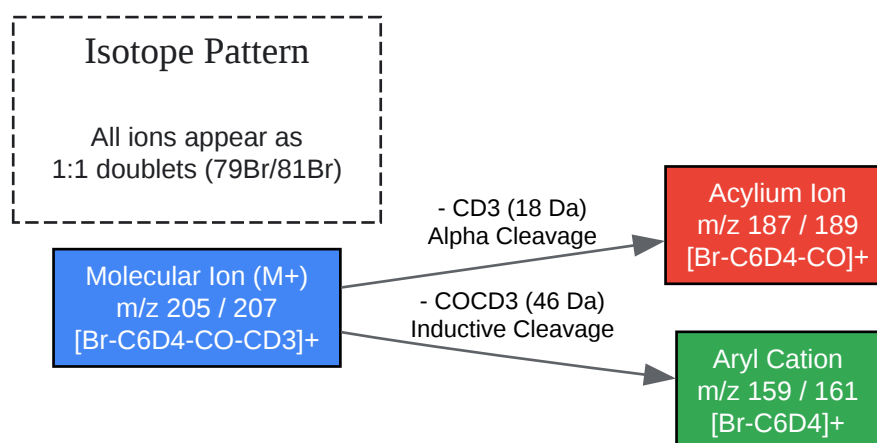

[Click to download full resolution via product page](#)

Figure 1: Predicted Electron Ionization (EI) fragmentation pathway for 4'-Bromoacetophenone-d7, highlighting the mass shifts due to specific deuterium losses.

Part 3: Nuclear Magnetic Resonance (NMR) Analysis

NMR is the definitive test for isotopic purity. A high-quality d7 standard must be "silent" in proton NMR.

Proton (¹H) NMR: The "Silence" Test

- d0 Reference: Shows AA'BB' multiplet (7.6–7.8 ppm) and a methyl singlet (2.6 ppm).
- d7 Expectation: No signals observed.

- Protocol: Acquire a spectrum with high gain. Any observed peaks represent residual non-deuterated isotopologues (d0–d6) or impurities.
- Limit of Detection: Typically < 1% residual H is acceptable for internal standards.

Carbon-13 (C) NMR: Coupling Effects

Unlike the sharp singlets of the parent compound, the d7 analog exhibits multiplets due to Carbon-Deuterium spin-spin coupling (

) and the lack of Nuclear Overhauser Effect (NOE) enhancement.

Predicted

C Shifts & Multiplicities:

Carbon Position	Approx.[1][2] Shift (ppm)	Multiplicity (due to D)	Coupling ()	Explanation
Carbonyl (C=O)	197.0	Singlet (broad)	~0 Hz	Too far from D sources.
Aromatic C-Br (C4)	128.0	Singlet	~0 Hz	Quaternary.
Aromatic C-H (C2, C6)	131.5	Triplet ()	~25 Hz	One attached D ().
Aromatic C-H (C3, C5)	130.0	Triplet ()	~25 Hz	One attached D ().
Aromatic C-Acetyl (C1)	135.5	Singlet	~0 Hz	Quaternary.
Methyl ()	25.5	Septet ()	~20 Hz	Three attached D's.

Note: Chemical shifts may show a slight upfield isotope shift (

ppm) compared to the d0 parent.

Part 4: Vibrational Spectroscopy (IR)

The substitution of Hydrogen with Deuterium doubles the reduced mass (

) of the oscillator, lowering the vibrational frequency according to Hooke's Law:

Vibrational Mode	Parent (d0) Frequency ()	d7 Frequency ()	Interpretation
Aromatic C-H Stretch	3050 – 3080	2260 – 2290	Diagnostic "Silent Region" band.
Aliphatic C-H Stretch	2900 – 3000	2100 – 2250	Methyl group C-D stretch.
Ketone C=O Stretch	1685	1680 – 1685	Minimal shift (mass effect is distal).
Aromatic Ring Breathing	1580, 1480	1560, 1450	Slight redshift due to ring mass increase.

Part 5: Experimental Protocols

Protocol: Analytical Validation of Isotopic Purity

This workflow ensures the material is suitable for use as a quantitative Internal Standard.

Reagents:

- Solvent: Chloroform-d (, 99.8% D) or DMSO-d6.
- Internal Reference (optional): TMS (Tetramethylsilane).

Step-by-Step Methodology:

- Sample Prep: Dissolve 10 mg of 4'-Bromoacetophenone-d7 in 0.6 mL
 . Ensure complete solvation.
- H NMR Acquisition:
 - Set spectral width to -2 to 14 ppm.
 - Set relaxation delay () to > 5 seconds (to allow relaxation of any residual protons).
 - Scans: Minimum 64 (to detect trace H).
 - Pass Criteria: No peaks > 1% height relative to the solvent residual peak (CHCl₃ at 7.26 ppm).
- MS Direct Infusion:
 - Dilute sample to 1 µg/mL in Methanol.
 - Infuse into ESI-MS (Positive Mode).
 - Scan range: 150–250 Da.
 - Pass Criteria: Major peaks at 205/207. Absence of 198/200 peaks (< 0.5% abundance).

Visualization: Analytical Workflow

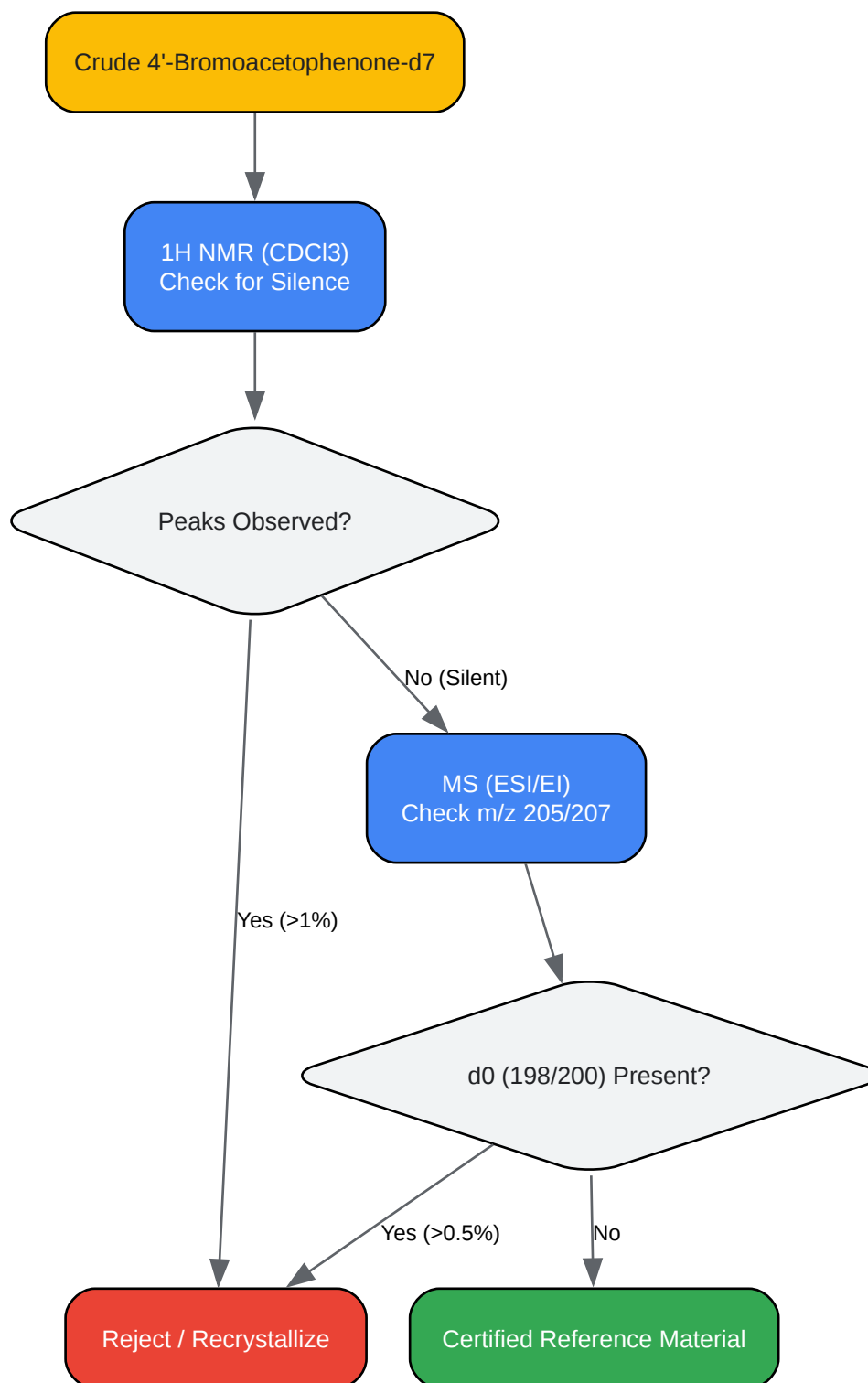

[Click to download full resolution via product page](#)

Figure 2: Validation workflow for certifying the isotopic purity of the d7 standard.

References

- National Institute of Standards and Technology (NIST). (2023). Mass Spectrum of 4'-Bromoacetophenone (Unlabeled Parent). NIST Chemistry WebBook, SRD 69.[3] Retrieved from [[Link](#)]
- Silverstein, R. M., Webster, F. X., & Kiemle, D. J. (2005). Spectrometric Identification of Organic Compounds. (7th Ed.). John Wiley & Sons. (Authoritative text on Isotope Effects in NMR/IR).
- Organic Syntheses. (1925). p-Bromoacetophenone Synthesis (Parent Compound Reference). Org. Synth. 1925, 5, 21. Retrieved from [[Link](#)]

Need Custom Synthesis?

BenchChem offers custom synthesis for rare earth carbides and specific isotopic labeling.

Email: info@benchchem.com or [Request Quote Online](#).

Sources

- 1. 4-bromoacetophenone | Sigma-Aldrich [[sigmaaldrich.com](https://www.sigmaaldrich.com)]
- 2. [rsc.org](https://www.rsc.org) [[rsc.org](https://www.rsc.org)]
- 3. Ethanone, 1-(4-bromophenyl)- [webbook.nist.gov]
- To cite this document: BenchChem. [Technical Guide: Spectroscopic Profiling of 4'-Bromoacetophenone-d7]. BenchChem, [2026]. [Online PDF]. Available at: [<https://www.benchchem.com/product/b580897/docs#technical-guide-spectroscopic-profiling-of-4-bromoacetophenone-d7>]

Disclaimer & Data Validity:

The information provided in this document is for Research Use Only (RUO) and is strictly not intended for diagnostic or therapeutic procedures. While BenchChem strives to provide accurate protocols, we make no warranties, express or implied, regarding the fitness of this product for every specific experimental setup.

Technical Support: The protocols provided are for reference purposes. Unsure if this reagent suits your experiment?

Need Industrial/Bulk Grade? [Request Custom Synthesis Quote](#)

BenchChem

Our mission is to be the trusted global source of essential and advanced chemicals, empowering scientists and researchers to drive progress in science and industry.

Contact

Address: 3281 E Guasti Rd
Ontario, CA 91761, United States
Phone: (601) 213-4426
Email: info@benchchem.com

[Contact our Ph.D. Support Team for a compatibility check](#)