

# Mass Spectrometry Fragmentation Patterns of Halogenated Imidazopyridines: A Technical Comparison Guide

**Author:** BenchChem Technical Support Team. **Date:** May 2026

## Compound of Interest

Compound Name:	5-Bromo-2-chloro-3H-imidazo[4,5-b]pyridine
CAS No.:	1260669-88-2
Cat. No.:	B580892

[Get Quote](#)

## Executive Summary: Decoding the Scaffold

The imidazo[1,2-a]pyridine scaffold is a "privileged structure" in medicinal chemistry, forming the core of blockbuster drugs like Zolpidem (hypnotic), Alpidem (anxiolytic), and emerging anti-infectives.<sup>[1]</sup> When halogenated (Cl, Br, F), these molecules exhibit distinct mass spectrometric behaviors that are critical for structural elucidation and impurity profiling.

This guide moves beyond basic spectral interpretation, offering a comparative analysis of ionization techniques, fragmentation mechanics, and a self-validating experimental protocol for characterizing these heterocycles.

## Strategic Comparison: Ionization Modalities

The choice between Electrospray Ionization (ESI) and Electron Impact (EI) fundamentally alters the observed fragmentation landscape.

Feature	ESI-MS/MS (Soft Ionization)	EI-MS (Hard Ionization)
Primary Species	Protonated Molecular Ion (Even-electron)	Radical Cation (Odd-electron)
Halogen Stability	High. C-Cl and C-Br bonds often survive initial ionization. Halogens are retained in daughter ions, preserving isotopic patterns.	Low to Moderate. Weak C-Br and C-I bonds frequently cleave immediately, leading to base peaks.
Fragmentation Logic	Collision Induced Dissociation (CID).[2][3] Driven by proton mobility.[2] Neutral losses (e.g., CO, HCN) dominate.	High-energy radical-induced cleavage. Ring opening and radical losses (e.g., , ) are common.
Best Application	Pharmacokinetics/Metabolite ID. Tracking the intact scaffold in biological matrices.	Synthetic Verification. Confirming regiochemistry and elemental composition via isotopic fingerprints.

## Mechanistic Deep Dive: Fragmentation Architectures

### The Halogen Hierarchy (Bond Strength vs. Lability)

Fragmentation is governed by the bond dissociation energy (BDE) of the carbon-halogen bond relative to the heterocyclic ring stability.

- Fluoro- (C-F): The C-F bond is stronger than the heterocyclic ring bonds. Fragmentation rarely involves F loss. Instead, look for ring cleavage (loss of HCN, CH<sub>3</sub>CN) with the fluorine atom still attached to the fragment.
- Chloro- (C-Cl): Intermediate stability. In ESI, the chlorine is usually retained until high collision energies (CE > 30 eV) are applied.

- Bromo- (C-Br): The "Weak Link". In EI, the loss of

is often the base peak. In ESI, the loss of neutral HBr can occur if a proton source (like an adjacent alkyl group) is available.

## Diagnostic Isotopic Signatures

Before analyzing fragmentation, validate the precursor ion using the "Rule of Isotopes":

- Chlorine: M and M+2 peaks in a 3:1 intensity ratio.
- Bromine: M and M+2 peaks in a 1:1 intensity ratio.
- Mixed (Br + Cl): Distinct "staircase" patterns (M, M+2, M+4).

## The Core Fragmentation Pathway (ESI-MS/MS)

For a typical 2-phenylimidazo[1,2-a]pyridine, the fragmentation follows a predictable cascade:

- Side Chain Ejection: If alkyl or amide groups are present (e.g., Zolpidem), these cleave first. The imidazopyridine core is highly stable.[\[4\]](#)
- Ring Contraction/Opening:
  - Loss of HCN (27 Da): Characteristic of the imidazole ring.
  - Loss of CH<sub>3</sub>CN (41 Da): Occurs if a methyl group is on the ring (common in drug scaffolds).
  - Retro-Cheletropic Elimination: Loss of CO if a carbonyl is attached to the ring.

## Visualization: Fragmentation Pathway

The following diagram illustrates the fragmentation of a model 6-chloro-2-phenylimidazo[1,2-a]pyridine under ESI-MS/MS conditions.

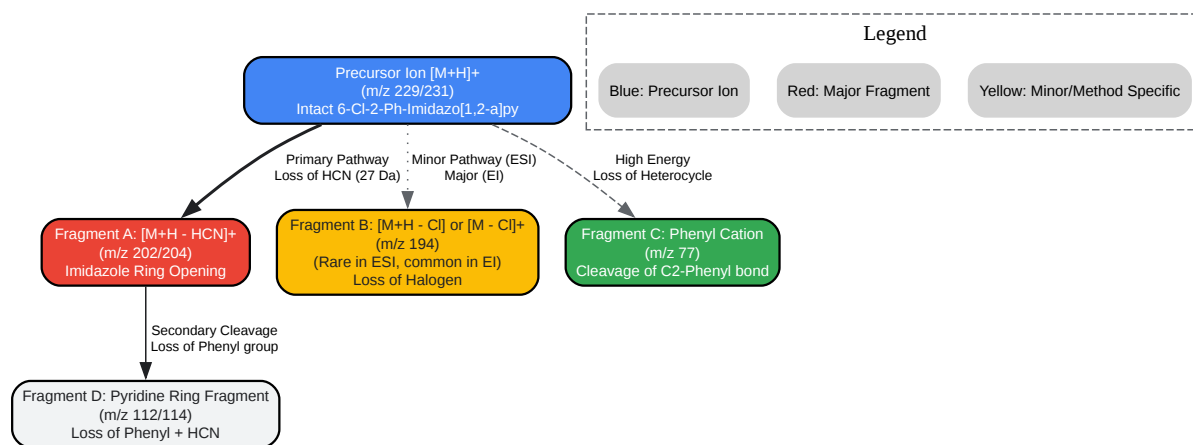

[Click to download full resolution via product page](#)

Caption: Figure 1. Proposed ESI-MS/MS fragmentation tree for 6-chloro-2-phenylimidazo[1,2-a]pyridine. The primary pathway involves imidazole ring degradation (HCN loss) while retaining the halogen.

## Experimental Protocol: Self-Validating Workflow

Objective: Characterize unknown halogenated imidazopyridines using LC-ESI-MS/MS.

### Phase 1: Chromatographic Separation

- Column: C18 Reverse Phase (e.g., Kinetex 2.6  $\mu\text{m}$ , 100  $\text{\AA}$ ).
- Mobile Phase A: 0.1% Formic Acid in Water (Proton source for ESI).
- Mobile Phase B: Acetonitrile (ACN).
- Gradient: 5% B to 95% B over 10 minutes. Note: Halogenated species are lipophilic and will elute late.

## Phase 2: Mass Spectrometry Settings (Triple Quadrupole/Q-TOF)

- Source: ESI Positive Mode ( ).
- Capillary Voltage: 3.5 kV.
- Collision Energy (CE) Ramping:
  - Step 1 (Low CE, 10-20 eV): Preserve molecular ion ( ) to confirm isotopic pattern (Cl vs Br).
  - Step 2 (High CE, 35-50 eV): Force ring fragmentation to identify the core structure.

## Phase 3: Data Validation (The "Checklist")

- Isotope Check: Does the parent ion show the 3:1 (Cl) or 1:1 (Br) pattern?
- Even-Electron Rule: In ESI, fragments should generally be even-electron ions. Radical losses (odd mass loss from even mass parent) suggest unusual stability or EI-like behavior.
- Nitrogen Rule: An even molecular weight implies an even number of nitrogens (0, 2, 4).  
Imidazopyridines have 2 nitrogens, so  
  
is even, and  
  
is odd.

## Data Summary: Diagnostic Ions

Fragment Description	m/z (Generic)	m/z (Example: Zolpidem*)	Significance
Protonated Molecule		308	Precursor confirmation.
Loss of Amide/Side Chain		236	Base Peak. Indicates stability of the imidazopyridine core.
Core + Methyl		222	Loss of lateral carbonyl/amide groups.
Pyridine Ring Fragment	~78 - 80	79	Indicates the pyridine portion of the fused ring.
Tropylium Ion	91	91	Present if a benzyl/phenyl group is attached (rearrangement).
HCN Loss		-	Diagnostic for imidazole ring opening.

\*Zolpidem data adapted from stress degradation studies [1, 2].

## References

- Vertex AI Search Result 1.2 & 1.4: Malesevic, M. et al. "Stress degradation studies on zolpidem tartrate using LC-DAD and LC-MS methods." ResearchGate. Available at: [\[Link\]](#)
- Vertex AI Search Result 1.6: "Gas-phase fragmentation of protonated 3-phenoxy imidazo[1,2-a] pyridines using tandem mass spectrometry." PubMed. Available at: [\[Link\]](#)
- Vertex AI Search Result 1.5: "Simultaneous ESI-APCI+ ionization and fragmentation pathways for nine benzodiazepines and zolpidem." PubMed. Available at: [\[Link\]](#)

### Need Custom Synthesis?

BenchChem offers custom synthesis for rare earth carbides and specific isotopic labeling.

Email: [info@benchchem.com](mailto:info@benchchem.com) or [Request Quote Online](#).

## Sources

- [1. Imidazo\[1,2-a\]pyridines in Medicinal Chemistry: Recent Advances in Synthesis and Biological Activities - PMC \[pmc.ncbi.nlm.nih.gov\]](#)
- [2. gala.gre.ac.uk \[gala.gre.ac.uk\]](#)
- [3. Simultaneous ESI-APCI+ ionization and fragmentation pathways for nine benzodiazepines and zolpidem using single quadrupole LC-MS - PubMed \[pubmed.ncbi.nlm.nih.gov\]](#)
- [4. researchgate.net \[researchgate.net\]](#)
- To cite this document: BenchChem. [Mass Spectrometry Fragmentation Patterns of Halogenated Imidazopyridines: A Technical Comparison Guide]. BenchChem, [2026]. [Online PDF]. Available at: [<https://www.benchchem.com/product/b580892/docs#mass-spectrometry-fragmentation-patterns-of-halogenated-imidazopyridines-a-technical-comparison-guide>]

---

### Disclaimer & Data Validity:

The information provided in this document is for Research Use Only (RUO) and is strictly not intended for diagnostic or therapeutic procedures. While BenchChem strives to provide accurate protocols, we make no warranties, express or implied, regarding the fitness of this product for every specific experimental setup.

**Technical Support:** The protocols provided are for reference purposes. Unsure if this reagent suits your experiment?

**Need Industrial/Bulk Grade?** [Request Custom Synthesis Quote](#)

# BenchChem

Our mission is to be the trusted global source of essential and advanced chemicals, empowering scientists and researchers to drive progress in science and industry.

## Contact

Address: 3281 E Guasti Rd

Ontario, CA 91761, United States

Phone: (601) 213-4426

Email: [info@benchchem.com](mailto:info@benchchem.com)

[Contact our Ph.D. Support Team for a compatibility check](#)