

Introduction: Strategic Importance in Modern Chemistry

Author: BenchChem Technical Support Team. **Date:** May 2026

Compound of Interest

Compound Name:	2-(Tert-butyl- dimethylsilyl)thiophene
CAS No.:	163079-25-2
Cat. No.:	B066596

[Get Quote](#)

Thiophene and its derivatives represent a cornerstone of heterocyclic chemistry, forming the structural core of numerous pharmaceuticals, agrochemicals, and high-performance organic electronic materials.[1] The strategic functionalization of the thiophene ring is paramount to tuning the physicochemical properties of these advanced materials. In this context, silyl protecting groups, particularly the tert-butyldimethylsilyl (TBDMS) group, serve as versatile tools for synthetic chemists.

2-(Tert-butyldimethylsilyl)thiophene is not merely a protected form of thiophene; it is a key synthetic intermediate. The TBDMS group serves two primary strategic functions:

- **Transient Protection:** It effectively blocks the highly reactive C-2 position of the thiophene ring, preventing unwanted side reactions during subsequent synthetic transformations.
- **Regiocontrol Element:** It acts as a powerful directing group, facilitating selective functionalization at the C-5 position through directed ortho-metalation (DoM), a level of control not easily achieved with unsubstituted thiophene.

This guide provides an in-depth exploration of the core properties, synthesis, and reactive landscape of **2-(Tert-butyldimethylsilyl)thiophene**, offering field-proven insights and detailed protocols for researchers in materials science and drug development.

Physicochemical and Spectroscopic Properties

A comprehensive understanding of a compound's physical and spectral properties is the foundation of its effective application.

Physical and Chemical Data

The fundamental properties of **2-(Tert-butyldimethylsilyl)thiophene** are summarized in the table below. This data is critical for reaction setup, purification, and safety considerations.

Property	Value	Source(s)
CAS Number	163079-25-2	[2][3][4]
Molecular Formula	C ₁₀ H ₁₈ SSi	[4][5]
Molecular Weight	198.40 g/mol	[4][5]
Appearance	Colorless to pale yellow liquid	-
Density	0.929 g/mL at 25 °C	[4]
Boiling Point	40-45 °C at 0.2 mmHg	[4][6]
Flash Point	77 °C	[4]
InChI Key	HDERSDBULDLBGI- UHFFFAOYSA-N	[5]

Spectroscopic Profile (Predicted)

While a publicly available, experimentally verified spectrum for this specific compound is not readily found, its spectral characteristics can be accurately predicted based on established principles of spectroscopy and data from analogous structures.

- ¹H NMR (CDCl₃, 400 MHz): The proton NMR spectrum is expected to show signals for the three thiophene ring protons and the TBDMS group.

- δ ~7.4-7.5 ppm (dd, 1H): H-5 proton, deshielded by the sulfur atom.
- δ ~7.1-7.2 ppm (dd, 1H): H-3 proton, adjacent to the silyl group.
- δ ~7.0-7.1 ppm (dd, 1H): H-4 proton.
- δ ~0.9 ppm (s, 9H): The nine equivalent protons of the tert-butyl group.
- δ ~0.3 ppm (s, 6H): The six equivalent protons of the two methyl groups on the silicon atom.
- ^{13}C NMR (CDCl_3 , 101 MHz): The carbon spectrum will reflect the silylated thiophene core.
 - δ ~145-148 ppm: C-2 (ipso-carbon attached to silicon).
 - δ ~135-138 ppm: C-5.
 - δ ~128-130 ppm: C-3.
 - δ ~127-129 ppm: C-4.
 - δ ~26-27 ppm: Methyl carbons of the tert-butyl group.
 - δ ~17-18 ppm: Quaternary carbon of the tert-butyl group.
 - δ ~ -5 to -7 ppm: Methyl carbons attached to the silicon.
- Mass Spectrometry (EI): The mass spectrum would be expected to show the molecular ion (M^+) at $m/z = 198$. A prominent peak at $m/z = 141$, corresponding to the loss of the tert-butyl group ($[\text{M}-57]^+$), is a characteristic fragmentation pattern for TBDMS-protected compounds.

Synthesis of 2-(Tert-butyldimethylsilyl)thiophene

The most reliable and widely adopted method for the synthesis of this compound is the direct lithiation of thiophene followed by electrophilic quenching with tert-butyldimethylsilyl chloride (TBDMS-Cl). This approach is highly efficient and selective.

Causality of Experimental Design:

- **Base Selection:** n-Butyllithium (n-BuLi) is used because it is a sufficiently strong base to deprotonate the C-2 position of thiophene, which has a pKa of approximately 33.[3]
- **Solvent:** Anhydrous tetrahydrofuran (THF) is the solvent of choice as it is aprotic and effectively solvates the lithium cation, preventing aggregation of the organolithium reagent and promoting reactivity.[7]
- **Temperature Control:** The reaction is conducted at cryogenic temperatures (-40 to -20 °C) to prevent side reactions, such as the decomposition of the 2-thienyllithium intermediate and potential reaction of n-BuLi with the solvent.[7]

Diagram: Synthetic Workflow

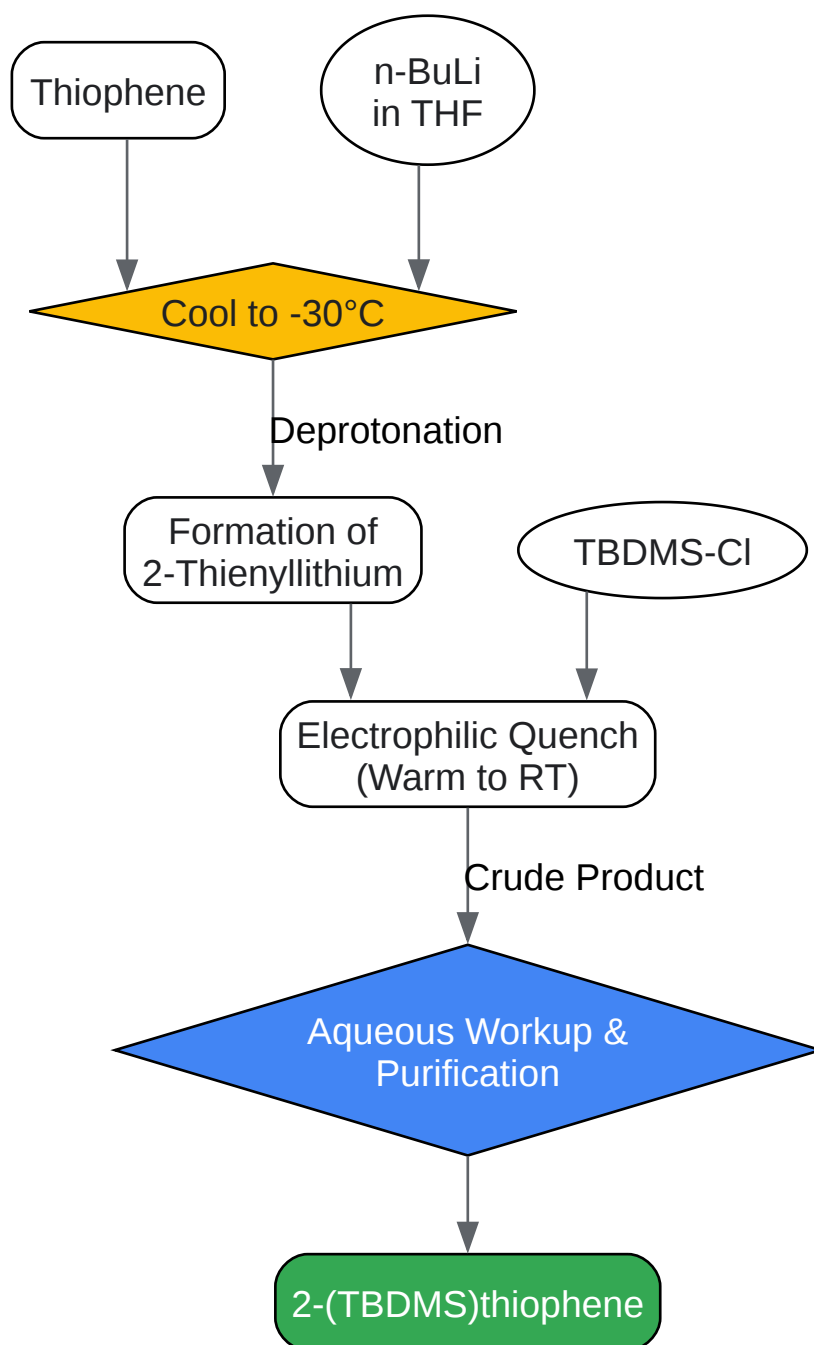

[Click to download full resolution via product page](#)

Caption: Workflow for the synthesis of 2-(TBDMS)thiophene.

Experimental Protocol: Synthesis

Materials:

- Thiophene (1.0 eq)

- n-Butyllithium (1.05 eq, solution in hexanes)
- Tert-butyldimethylsilyl chloride (TBDMS-Cl, 1.1 eq)
- Anhydrous Tetrahydrofuran (THF)
- Saturated aqueous ammonium chloride (NH₄Cl)
- Diethyl ether
- Magnesium sulfate (MgSO₄)

Procedure:

- **Reaction Setup:** Flame-dry a three-necked round-bottom flask equipped with a magnetic stir bar, a thermometer, a nitrogen inlet, and a rubber septum. Allow the flask to cool to room temperature under a positive pressure of nitrogen.
- **Initial Charge:** Add anhydrous THF to the flask, followed by thiophene (1.0 eq) via syringe.
- **Cooling:** Cool the solution to -40 °C using a dry ice/acetone bath.
- **Lithiation:** Add n-butyllithium (1.05 eq) dropwise via syringe over 15 minutes, ensuring the internal temperature is maintained between -30 °C and -20 °C.
- **Stirring:** Stir the resulting solution at this temperature for 1 hour to ensure complete formation of the 2-thienyllithium intermediate.^[7]
- **Electrophilic Quench:** Slowly add TBDMS-Cl (1.1 eq) to the reaction mixture. After the addition is complete, allow the mixture to slowly warm to room temperature and stir for an additional 2 hours.
- **Work-up:** Cool the reaction to 0 °C and carefully quench by the slow addition of saturated aqueous NH₄Cl. Transfer the mixture to a separatory funnel and dilute with diethyl ether.
- **Extraction:** Wash the organic layer sequentially with water and brine. Dry the organic phase over anhydrous MgSO₄, filter, and concentrate under reduced pressure.

- Purification: Purify the crude product by vacuum distillation to yield **2-(Tert-butyldimethylsilyl)thiophene** as a clear liquid.

Reactivity and Synthetic Utility

The TBDMS group imparts a rich and useful reactivity profile to the thiophene ring, enabling selective transformations that are otherwise challenging.

Directed Metalation at the C-5 Position

With the C-2 position blocked, the TBDMS group acts as a directed metalation group (DMG), guiding deprotonation to the adjacent C-5 position. This provides a reliable entry point to 2,5-disubstituted thiophenes.

Causality of Experimental Design:

- Base: sec-Butyllithium or tert-butyllithium are often preferred for this step as they are more reactive than n-BuLi and can overcome any potential steric hindrance. The addition of a chelating agent like TMEDA (tetramethylethylenediamine) can further accelerate the reaction by breaking up organolithium aggregates.
- Electrophile: This lithiated intermediate is a potent nucleophile and can react with a vast range of electrophiles (e.g., aldehydes, ketones, alkyl halides, CO₂, iodine, chlorostannanes) to install a new functional group at C-5.

Diagram: C-5 Lithiation and Functionalization

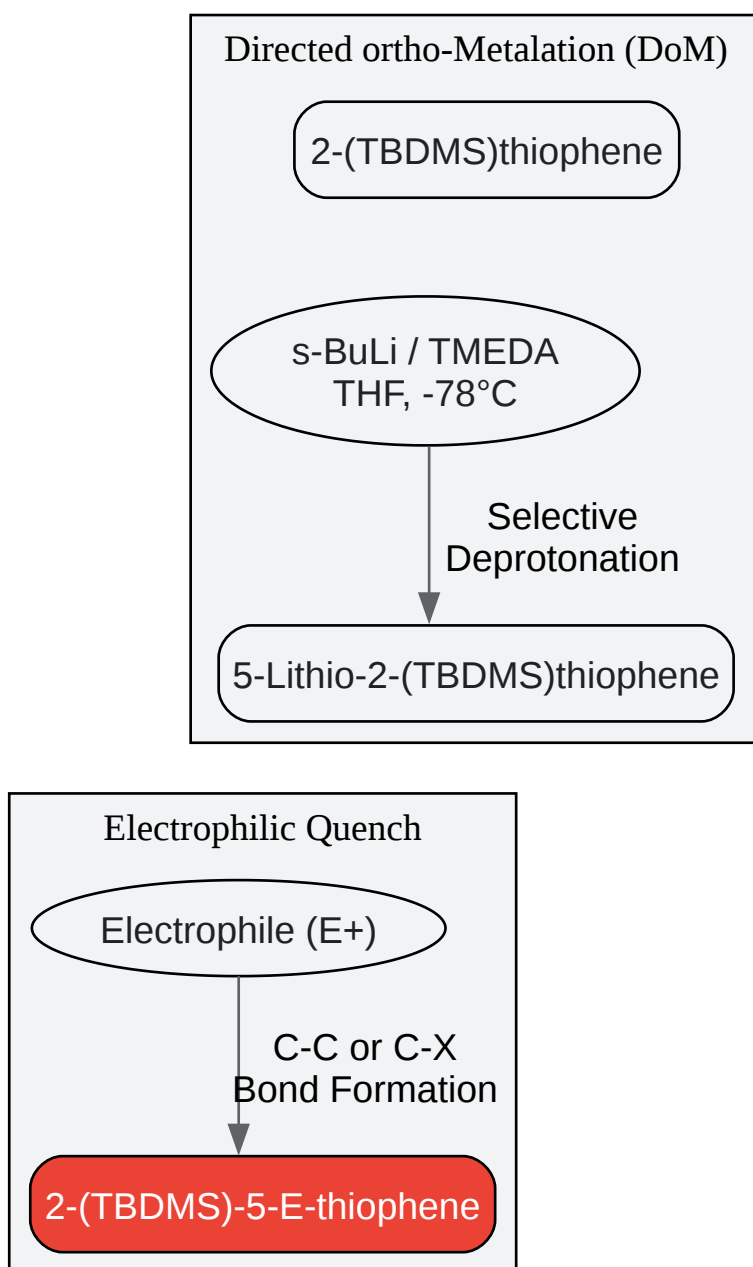

[Click to download full resolution via product page](#)

Caption: Regioselective functionalization via C-5 lithiation.

Experimental Protocol: 5-Bromination via Directed Metalation

This protocol exemplifies the functionalization at C-5 using bromine as the electrophile.

Materials:

- **2-(Tert-butyldimethylsilyl)thiophene** (1.0 eq)
- sec-Butyllithium (1.1 eq, solution in cyclohexane)
- Anhydrous Tetrahydrofuran (THF)
- Bromine (Br₂, 1.2 eq) or 1,2-Dibromoethane
- Saturated aqueous sodium thiosulfate (Na₂S₂O₃)

Procedure:

- Reaction Setup: Prepare a flame-dried, nitrogen-purged flask as described in the synthesis protocol.
- Initial Charge: Add anhydrous THF and **2-(Tert-butyldimethylsilyl)thiophene** (1.0 eq).
- Cooling: Cool the solution to -78 °C using a dry ice/acetone bath.
- Lithiation: Slowly add sec-butyllithium (1.1 eq) dropwise. Stir the mixture at -78 °C for 1 hour.
- Electrophilic Quench: Add a solution of bromine (1.2 eq) in anhydrous THF dropwise, ensuring the temperature remains below -70 °C. Alternatively, a less hazardous brominating agent like 1,2-dibromoethane can be used.
- Warming and Work-up: After stirring for 30 minutes at -78 °C, allow the reaction to warm to room temperature. Quench with saturated aqueous Na₂S₂O₃ to destroy excess bromine.
- Extraction and Purification: Extract the product into diethyl ether, wash with brine, dry over MgSO₄, and concentrate. Purify the resulting crude 5-bromo-**2-(tert-butyldimethylsilyl)thiophene** by flash column chromatography or vacuum distillation.

Protodesilylation: Removal of the TBDMS Group

The ability to easily remove the silyl group is crucial for its utility as a protecting group. This is typically achieved using a fluoride source or under acidic conditions.

Causality of Experimental Design:

- Fluoride Source: Tetrabutylammonium fluoride (TBAF) is the most common reagent for this transformation. The high affinity of fluoride for silicon (Si-F bond energy is very high) is the driving force for the cleavage of the C-Si bond.[8]
- Solvent: THF is an ideal solvent as it solubilizes both the substrate and the TBAF reagent.

Diagram: Protodesilylation Pathway

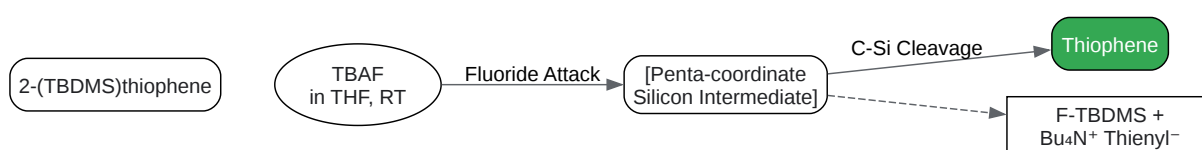

[Click to download full resolution via product page](#)

Caption: Mechanism of fluoride-mediated protodesilylation.

Experimental Protocol: Protodesilylation

Materials:

- **2-(Tert-butyldimethylsilyl)thiophene** (or a 5-substituted derivative) (1.0 eq)
- Tetrabutylammonium fluoride (TBAF) (1.1 eq, 1 M solution in THF)
- Tetrahydrofuran (THF)

Procedure:

- Reaction Setup: To a round-bottom flask, add the silylated thiophene (1.0 eq) and THF.
- Reagent Addition: Add the TBAF solution (1.1 eq) at room temperature.[8]
- Reaction Monitoring: Stir the reaction at room temperature. Monitor the progress by thin-layer chromatography (TLC) or GC-MS until the starting material is consumed (typically 1-4

hours).

- Work-up: Dilute the reaction mixture with diethyl ether and wash thoroughly with water (3x) to remove TBAF and its byproducts.
- Purification: Dry the organic layer over MgSO_4 , filter, and concentrate. Purify the resulting thiophene derivative by flash column chromatography if necessary.

Applications in Research and Development

2-(Tert-butyldimethylsilyl)thiophene is a valuable building block for creating more complex, functionalized thiophene-based molecules.

- Organic Electronics: Thiophene oligomers and polymers are premier organic semiconductors. The controlled, sequential functionalization enabled by the TBDMS group allows for the synthesis of well-defined conjugated systems for use in Organic Field-Effect Transistors (OFETs), Organic Photovoltaics (OPVs), and Organic Light-Emitting Diodes (OLEDs).[9]
- Drug Discovery: The thiophene scaffold is a known "privileged structure" in medicinal chemistry, appearing in numerous approved drugs.[1][10] The ability to selectively introduce substituents at the C-5 position allows for the rapid generation of libraries of novel thiophene derivatives for screening against biological targets.

Safety Considerations

- Organolithium Reagents (n-BuLi, s-BuLi): These reagents are pyrophoric and react violently with water and protic solvents. They must be handled under a strict inert atmosphere (nitrogen or argon) by trained personnel. Always use proper syringe and cannula techniques.
- Bromine: Is highly corrosive, toxic, and a strong oxidizing agent. Handle in a well-ventilated fume hood with appropriate personal protective equipment (gloves, goggles, lab coat).
- Solvents: Anhydrous THF can form explosive peroxides. Use freshly distilled or inhibitor-free solvent from a sealed bottle.

This guide provides the fundamental knowledge and practical protocols necessary for the effective use of **2-(Tert-butyldimethylsilyl)thiophene**. By understanding the causality behind the experimental procedures, researchers can confidently leverage this versatile intermediate to advance their projects in materials science and drug discovery.

References

- The Synthesis and Applications of 2,5-Dibromothiophene: A Comprehensive Look. (n.d.). NINGBO INNO PHARMCHEM CO.,LTD. Retrieved from [\[Link\]](#)
- Preparation of 2,5-dibromothiophen. (n.d.). PrepChem.com. Retrieved from [\[Link\]](#)
- ¹H NMR of methyl thiophene-2-carboxylate (1) in CDCl₃, Bruker-400. (n.d.). Retrieved from [\[Link\]](#)
- A Novel Synthesis of 2,5-Dibromo-3-[2-2(Methoxyethoxy)Ethoxy]Methylthiophene. (n.d.). JOCP. Retrieved from [\[Link\]](#)
- Product transformations. a) TBAF, THF, RT, 1 h. b) LiAlH₄, THF, 60 °C... (n.d.). ResearchGate. Retrieved from [\[Link\]](#)
- Transformation of Silyl-Protected Tetrafluorinated Thia[5]helicene S-Oxide into a Difluorinated Coronene via Induced Desilylation. (2020). Angewandte Chemie International Edition. Retrieved from [\[Link\]](#)
- ¹H NMR spectra, structure, and conformational exchange of S-n-alkyl-tetrahydrothiophenium cations. (2022). Magnetic Resonance in Chemistry. Retrieved from [\[Link\]](#)
- 2-Thienyl-tert-butyldimethylsilane | 163079-25-2. (n.d.). BuyersGuideChem. Retrieved from [\[Link\]](#)
- ¹H NMR Chemical Shift Values (δppm) for the Thiophene Proton of... (n.d.). ResearchGate. Retrieved from [\[Link\]](#)
- Electronic supplementary information for: A Rapid One-Step Surface Functionalization of Polyvinyl Chloride by Combining Click Sulfur(VI). (n.d.). The Royal Society of Chemistry. Retrieved from [\[Link\]](#)

- **2-(tert-Butyldimethylsilyl)thiophene** | 163079-25-2. (n.d.). BuyersGuideChem. Retrieved from [\[Link\]](#)
- tert-Butyl 5-(2-((tert-butyldimethylsilyl)oxy)ethyl)thiophene-2-carboxylate. (n.d.). PubChem. Retrieved from [\[Link\]](#)
- Thiophene synthesis. (n.d.). Organic Chemistry Portal. Retrieved from [\[Link\]](#)
- Deprotection of a tert-butyldimethylsilyl ether. (n.d.). ChemSpider Synthetic Pages. Retrieved from [\[Link\]](#)
- 2-thiophenethiol. (n.d.). Organic Syntheses Procedure. Retrieved from [\[Link\]](#)
- Removal of t-butyldimethylsilyl protection in RNA-synthesis. Triethylamine trihydrofluoride (TEA, 3HF) is a more reliable alternative to tetrabutylammonium fluoride (TBAF). (1995). Nucleic Acids Research. Retrieved from [\[Link\]](#)
- Derivatives and Synthesis of Heterocyclic Compound: Thiophene. (2022). Research & Reviews: Journal of Medicinal & Organic Chemistry. Retrieved from [\[Link\]](#)
- KHF₂: A Mild and Selective Desilylating Agent for Phenol tert-Butyldimethylsilyl (TBDMS) Ethers. (2017). Synlett. Retrieved from [\[Link\]](#)
- Synthesis and Biological Evaluation of Thiophene Derivatives as Acetylcholinesterase Inhibitors. (2012). Molecules. Retrieved from [\[Link\]](#)
- Scheme 45. Synthesis of bis(tert-butyldimethylsilyl)methanethiol and examples of other thiols formed from reaction of 10.4 with electrophiles. (n.d.). ResearchGate. Retrieved from [\[Link\]](#)
- Solvent-driven spectroscopic and quantum chemical evaluation of 2-[(trimethylsilyl)ethynyl]thiophene with molecular docking insights. (2023). Scientific Reports. Retrieved from [\[Link\]](#)
- Synthesis, properties and biological activity of thiophene: A review. (2011). Der Pharma Chemica. Retrieved from [\[Link\]](#)

Need Custom Synthesis?

BenchChem offers custom synthesis for rare earth carbides and specific isotopic labeling.

Email: info@benchchem.com or [Request Quote Online](#).

Sources

- 1. [derpharmachemica.com](https://www.derpharmachemica.com) [[derpharmachemica.com](https://www.derpharmachemica.com)]
- 2. [tert-Butyldimethyl\(thiophen-2-yl\)silane](#) | [CymitQuimica](https://www.cymitquimica.com) [[cymitquimica.com](https://www.cymitquimica.com)]
- 3. [2-Thienyl-tert-butyldimethylsilane](#) | 163079-25-2 - [BuyersGuideChem](https://www.buyersguidechem.com) [[buyersguidechem.com](https://www.buyersguidechem.com)]
- 4. [2-\(tert-Butyldimethylsilyl\)thiophene](#) | 163079-25-2 - [BuyersGuideChem](https://www.buyersguidechem.com) [[buyersguidechem.com](https://www.buyersguidechem.com)]
- 5. [tert-Butyldimethyl\(thiophen-2-yl\)silane](#) | [CymitQuimica](https://www.cymitquimica.com) [[cymitquimica.com](https://www.cymitquimica.com)]
- 6. [2-\(TERT-ブチルジメチルシリル\)チオフェン](#) | 163079-25-2 [[m.chemicalbook.com](https://www.m.chemicalbook.com)]
- 7. [Organic Syntheses Procedure](https://www.orgsyn.org) [[orgsyn.org](https://www.orgsyn.org)]
- 8. [Article](#) | [ChemSpider Synthetic Pages](https://www.cssp.chemspider.com) [[cssp.chemspider.com](https://www.cssp.chemspider.com)]
- 9. [nbinno.com](https://www.nbinno.com) [[nbinno.com](https://www.nbinno.com)]
- 10. [mdpi.com](https://www.mdpi.com) [[mdpi.com](https://www.mdpi.com)]
- To cite this document: BenchChem. [Introduction: Strategic Importance in Modern Chemistry]. BenchChem, [2026]. [Online PDF]. Available at: [<https://www.benchchem.com/product/b066596/docs#introduction-strategic-importance-in-modern-chemistry>]

Disclaimer & Data Validity:

The information provided in this document is for Research Use Only (RUO) and is strictly not intended for diagnostic or therapeutic procedures. While BenchChem strives to provide accurate protocols, we make no warranties, express or implied, regarding the fitness of this product for every specific experimental setup.

Technical Support: The protocols provided are for reference purposes. Unsure if this reagent suits your experiment?

Need Industrial/Bulk Grade? [Request Custom Synthesis Quote](#)

BenchChem

Our mission is to be the trusted global source of essential and advanced chemicals, empowering scientists and researchers to drive progress in science and industry.

Contact

Address: 3281 E Guasti Rd
Ontario, CA 91761, United States
Phone: (601) 213-4426
Email: info@benchchem.com

[Contact our Ph.D. Support Team for a compatibility check](#)