

# Comparative Reactivity Guide: 3-Iodo vs. 4-Iodo Fluoropyridines

**Author:** BenchChem Technical Support Team. **Date:** May 2026

## Compound of Interest

Compound Name: 2-Fluoro-3-iodo-4-methylpyridine

CAS No.: 1214323-08-6

Cat. No.: B580800

[Get Quote](#)

## Executive Summary

This guide provides a technical analysis of the reactivity differences between 3-iodo-fluoropyridines and 4-iodo-fluoropyridines. While both scaffolds are critical bioisosteres in kinase inhibitor and GPCR ligand design, their chemical behaviors diverge significantly due to the electronic influence of the pyridine nitrogen.

### Key Takeaways:

- **Cross-Coupling (Suzuki/Sonogashira):** The C4-I bond is kinetically more reactive toward oxidative addition than the C3-I bond due to the para-electron-deficient nature of the C4 position.
- **Lithiation (Halogen Dance):** 3-Iodo isomers are highly prone to the "Halogen Dance" rearrangement, where the iodine migrates to the C4 position upon lithiation. This requires strict cryogenic control (or continuous flow) to suppress.
- **Nucleophilic Substitution (**

): The position of the fluorine dictates

reactivity.[1] Iodine acts primarily as an electronic activator. 2-F and 4-F isomers are highly reactive; 3-F isomers are generally inert to

unless activated by strong EWGs.

## Electronic Landscape & Mechanistic Grounding

To predict reactivity, one must understand the electronic perturbation caused by the pyridine nitrogen.

- C4-Position (Para-like): The nitrogen atom exerts a strong electron-withdrawing effect via both induction (-I) and resonance (-M). This makes the C4 carbon highly electron-deficient, lowering the LUMO energy of the C-I bond and facilitating nucleophilic attacks or oxidative addition by metal catalysts.
- C3-Position (Meta-like): The C3 position is affected primarily by induction but is not in direct conjugation with the nitrogen lone pair sink. It is relatively more electron-rich than C4.

## Reactivity Hierarchy Visualization

The following diagram illustrates the divergent reaction pathways for a generic 2-fluoro-iodopyridine scaffold.

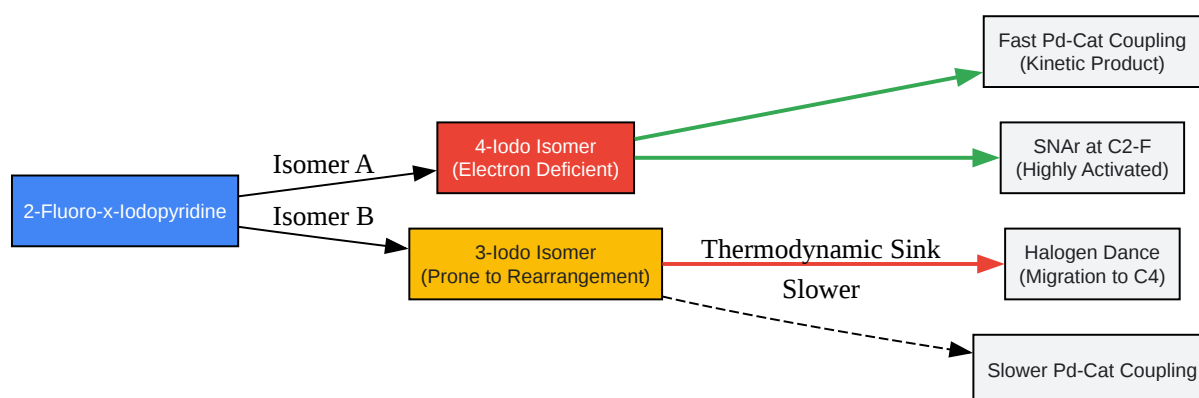

[Click to download full resolution via product page](#)

Figure 1: Divergent reactivity profiles. Note the "Halogen Dance" risk associated with the 3-iodo isomer.

## Palladium-Catalyzed Cross-Coupling[3][4][5] Comparative Performance

In competitive experiments involving poly-halogenated pyridines, the C4-I bond consistently reacts faster than the C3-I bond.

Feature	3-Iodo-Fluoropyridine	4-Iodo-Fluoropyridine	Mechanistic Rationale
Oxidative Addition Rate	Moderate	Fast	C4 is more electron-deficient (para to N), stabilizing the Pd(II) intermediate.
Regioselectivity	Secondary	Primary	In 3,4-diiodopyridines, coupling occurs exclusively at C4 first.
Catalyst Requirement	Standard ( )	Standard ( )	Both work with standard catalysts, but C4 achieves turnover at lower temperatures.

Supporting Data: Studies on 2-chloro-3,4-diiodopyridine demonstrate that Suzuki coupling occurs selectively at the C4 position first, followed by C3, and finally the C2-chlorine.[2] This establishes the reactivity order: C4-I > C3-I > C2-Cl.

## Experimental Protocol: Selective C4-Arylation

Applicable for 3-fluoro-4-iodopyridine

- Reagents: Substrate (1.0 equiv), Arylboronic acid (1.1 equiv),  
(0.05 equiv),

(2.0 equiv).

- Solvent: 1,4-Dioxane/Water (4:1).
- Conditions: Heat to 60°C under  
for 2-4 hours. Note: 3-iodo isomers typically require 80-90°C for comparable conversion.
- Workup: Dilute with EtOAc, wash with brine, dry over

## The "Halogen Dance" Phenomenon[7][8][9]

The most critical operational difference is the stability of the lithiated intermediates. 3-Iodo-fluoropyridines are notorious for the "Halogen Dance" (HD), where the lithium base removes a proton adjacent to the iodine, triggering a migration of the iodine atom to a more thermodynamically stable position (usually C4).

### Mechanism of Migration

The reaction is driven by the formation of a more stable carbanion, typically one stabilized by two flanking directing groups (e.g., F and I) or moving the anion to the C3 position (ortho to F) while the Iodine moves to C4.

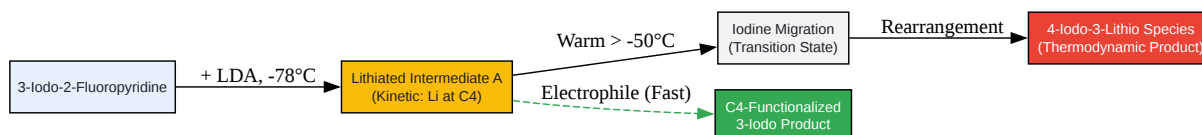

[Click to download full resolution via product page](#)

Figure 2: The Halogen Dance mechanism. To retain the 3-iodo motif, one must trap the kinetic intermediate immediately.

### Control Strategy

- To Retain 3-Iodo: Perform lithiation at  $-78^{\circ}\text{C}$  and add the electrophile immediately or use continuous flow chemistry to minimize the residence time of the lithiated species (second) before quenching.
- To Access 4-Iodo (via Dance): Treat 3-iodo-2-fluoropyridine with LDA at  $-40^{\circ}\text{C}$ . The iodine will migrate to C4, allowing electrophilic trapping at C3.

## Nucleophilic Aromatic Substitution ( )

In

, the iodine atom is rarely the leaving group if fluorine is present. Fluorine is displaced times faster.

Isomer	Fluorine Position	Reactivity	Notes
2-Fluoro-3-Iodopyridine	C2 (Ortho to N)	High	F is activated by N. Iodine at C3 exerts mild inductive activation.
2-Fluoro-4-Iodopyridine	C2 (Ortho to N)	High	Similar to above.
3-Fluoro-4-Iodopyridine	C3 (Meta to N)	Inert	C3-F is not activated by N. will not occur unless strong EWGs are added.
4-Fluoro-3-Iodopyridine	C4 (Para to N)	Very High	C4-F is highly activated. Iodine at C3 provides steric bulk but inductive activation.

Self-Validating Check: If attempting

on 3-fluoro-4-iodopyridine, expect no reaction or decomposition. If using 2-fluoro-4-iodopyridine, expect clean displacement of Fluorine by amines/alkoxides at mild temperatures (RT to 50°C).

## References

- Comparison of Reactivity in Pyridine Radical Cations (Electronic effects on 3 vs 4 position)  
Source: National Institutes of Health (NIH) URL:[[Link](#)]
- Continuous-Flow Divergent Lithiation: Deprotolithiation vs Halogen Dance (Definitive guide on controlling the dance) Source: Chemistry - A European Journal (via PubMed) URL:[[Link](#)]
- Site-selective Suzuki–Miyaura coupling of heteroaryl halides (Data on C4 vs C3 selectivity)  
Source: Chemical Science (RSC) URL:[[Link](#)]
- Halogen Dance Rearrangement Mechanism Source: Wikipedia (General Mechanism Overview) URL:[[Link](#)]

### Need Custom Synthesis?

BenchChem offers custom synthesis for rare earth carbides and specific isotopic labeling.

Email: [info@benchchem.com](mailto:info@benchchem.com) or [Request Quote Online](#).

## Sources

- [1. masterorganicchemistry.com](https://www.masterorganicchemistry.com) [[masterorganicchemistry.com](https://www.masterorganicchemistry.com)]
- [2. Site-selective Suzuki–Miyaura coupling of heteroaryl halides – understanding the trends for pharmaceutically important classes - Chemical Science \(RSC Publishing\)](#)  
DOI:10.1039/C6SC02118B [[pubs.rsc.org](https://pubs.rsc.org)]
- To cite this document: BenchChem. [Comparative Reactivity Guide: 3-Iodo vs. 4-Iodo Fluoropyridines]. BenchChem, [2026]. [Online PDF]. Available at: [<https://www.benchchem.com/product/b580800/docs#comparative-reactivity-guide-3-iodo-vs-4-iodo-fluoropyridines>]

### Disclaimer & Data Validity:

The information provided in this document is for Research Use Only (RUO) and is strictly not intended for diagnostic or therapeutic procedures. While BenchChem strives to provide accurate protocols, we make no warranties, express or implied, regarding the fitness of this product for every specific experimental setup.

**Technical Support:** The protocols provided are for reference purposes. Unsure if this reagent suits your experiment?

**Need Industrial/Bulk Grade?** [Request Custom Synthesis Quote](#)

## BenchChem

Our mission is to be the trusted global source of essential and advanced chemicals, empowering scientists and researchers to drive progress in science and industry.

### Contact

Address: 3281 E Guasti Rd  
Ontario, CA 91761, United States  
Phone: (601) 213-4426  
Email: [info@benchchem.com](mailto:info@benchchem.com)

[Contact our Ph.D. Support Team for a compatibility check](#)