

# Technical Support Center: A Scientist's Guide to Boldoside Solubility Enhancement

**Author:** BenchChem Technical Support Team. **Date:** May 2026

## Compound of Interest

|                |            |
|----------------|------------|
| Compound Name: | Boldoside  |
| CAS No.:       | 17331-71-4 |
| Cat. No.:      | B579224    |

[Get Quote](#)

## Introduction: The Boldoside Challenge

**Boldoside**, a flavonoid glycoside derived from the leaves of *Peumus boldus*, presents significant therapeutic potential owing to its antioxidant and hepatoprotective properties. However, like many flavonoid glycosides, its journey from the bench to preclinical or clinical application is frequently hampered by a critical physicochemical hurdle: poor aqueous solubility. This inherent limitation can lead to inconsistent experimental results, low bioavailability, and challenges in developing effective formulations.

This guide is structured to serve as a dedicated technical support resource for researchers, scientists, and drug development professionals. It moves beyond simple protocols to provide a deeper understanding of the mechanisms behind solubility enhancement, offering practical, step-by-step troubleshooting advice and in-depth methodologies to help you overcome the challenges associated with **boldoside's** solubility.

## Section 1: Frequently Asked Questions (FAQs)

This section addresses the most common initial questions and concerns regarding **boldoside** solubility.

Q1: What is the expected aqueous solubility of **boldoside**?

A: While a precise value for **boldoside** is not readily available in public literature, flavonoid glycosides as a class are known for their low water solubility. For instance, similar compounds like hesperidin have an aqueous solubility of less than 0.01 g/L at neutral pH and room temperature.<sup>[1]</sup> It is reasonable to assume that **boldoside** falls into a similarly "poorly soluble" or "sparingly soluble" category, necessitating enhancement for most experimental and therapeutic applications.

Q2: Why is **boldoside** poorly soluble in water?

A: The solubility of a molecule is a balance between its hydrophilic (water-loving) and hydrophobic (water-fearing) characteristics. **Boldoside** has a large, rigid polyphenolic backbone (the aglycone part) which is hydrophobic. While it possesses two sugar moieties (a glucoside and a rhamnoside) that are hydrophilic, their contribution is often insufficient to overcome the hydrophobicity of the large aglycone structure, leading to poor overall aqueous solubility.<sup>[2][3]</sup>

Q3: What is the quickest way to prepare a **boldoside** stock solution for a preliminary in vitro assay?

A: For initial cell-based assays, the most common and direct method is to use a co-solvent. Dimethyl sulfoxide (DMSO) is the standard choice.

- Initial Step: Prepare a high-concentration stock solution (e.g., 10-50 mM) by dissolving **boldoside** powder in 100% DMSO. Use gentle vortexing or sonication to aid dissolution.
- Working Solution: Dilute this stock solution directly into your cell culture medium to achieve the final desired concentration.
- Crucial Caveat: The final concentration of DMSO in the cell culture medium should be kept to a minimum, as it can be toxic to cells. A final concentration of  $\leq 0.5\%$  DMSO is generally considered safe for most cell lines, though some may tolerate up to 1%.<sup>[4][5][6][7]</sup> Always run a vehicle control (medium with the same final DMSO concentration but without **boldoside**) to account for any solvent effects.

Q4: How does pH impact the solubility and stability of **boldoside**?

A: The solubility and stability of flavonoids are often pH-dependent.[8]

- **Solubility:** For many flavonoids, solubility can increase at a higher (more alkaline) pH. For example, the solubility of rutin and tiliroside in an aqueous phase was found to be 4-6 times higher at pH 8 compared to pH 2.[9] This is due to the deprotonation of hydroxyl groups on the phenolic rings, which makes the molecule more polar.
- **Stability:** This increased solubility at alkaline pH comes at a cost. Flavonoids, especially those with catechol groups, are prone to oxidative degradation in alkaline environments.[10] [11] They are generally more stable at acidic to neutral pH. Therefore, while briefly using a higher pH to dissolve the compound might be an option, the long-term stability of the solution is compromised. For most applications, working in a pH range of 4-7.5 is advisable to balance solubility and stability.

## Section 2: Troubleshooting Common Experimental Issues

Direct answers to problems you might be facing in the lab right now.

Problem: My **boldoside**, diluted from a DMSO stock, is precipitating in the cell culture medium.

- **Causality:** This is a classic sign that the aqueous solubility limit has been exceeded. When the DMSO stock is added to the aqueous medium, the DMSO concentration drops dramatically, and the medium can no longer keep the hydrophobic **boldoside** in solution. This is especially common when preparing higher concentration working solutions.
- **Immediate Troubleshooting Steps:**
  - **Reduce Final Concentration:** The simplest solution is to lower the final concentration of **boldoside** in your experiment.
  - **Increase Serum Content:** If your experimental design allows, increasing the fetal bovine serum (FBS) percentage in the medium can help. Serum proteins like albumin can bind to hydrophobic compounds and help keep them in solution.
  - **Warm the Medium:** Gently warming the medium to 37°C before and after adding the **boldoside** stock can sometimes help, but be cautious as prolonged heating can degrade

the compound.

- Long-Term Solution: If you require higher concentrations, you must employ a formal solubility enhancement technique. Complexation with hydroxypropyl- $\beta$ -cyclodextrin (HP- $\beta$ -CD) is an excellent, cell-compatible option. (See Protocol in Section 3).

Problem: I'm observing high variability in my bioassay results between experiments.

- Causality: Inconsistent results are often a downstream effect of poor solubility. If **boldoside** is not fully dissolved, or if it begins to precipitate during the assay incubation period, the actual concentration of the compound available to the cells will vary, leading to unreliable data. Microscopic precipitates can also interfere with cell health and assay readouts (e.g., absorbance or fluorescence).
- Validation Protocol:
  - Visual Inspection: Before adding your working solution to cells, hold the flask or tube against a light source. Look for any cloudiness, haziness, or visible particles.
  - Microscopic Check: Examine a drop of your final working solution under a microscope. Crystalline structures or amorphous precipitates indicate a solubility problem.
  - Time-Course Solubility Check: Prepare your highest concentration working solution and let it sit at the assay temperature (e.g., 37°C) for the duration of your experiment (e.g., 24, 48 hours). Check for precipitation at the end of the period.
- Solution: Ensure complete dissolution in the stock and consider pre-complexing **boldoside** with a solubilizing agent like HP- $\beta$ -CD before preparing the final working solution.

## Section 3: A Scientist's Workflow for Selecting a Solubility Enhancement Method

The choice of method depends on your experimental goal. This decision tree provides a logical path for selecting the most appropriate technique.

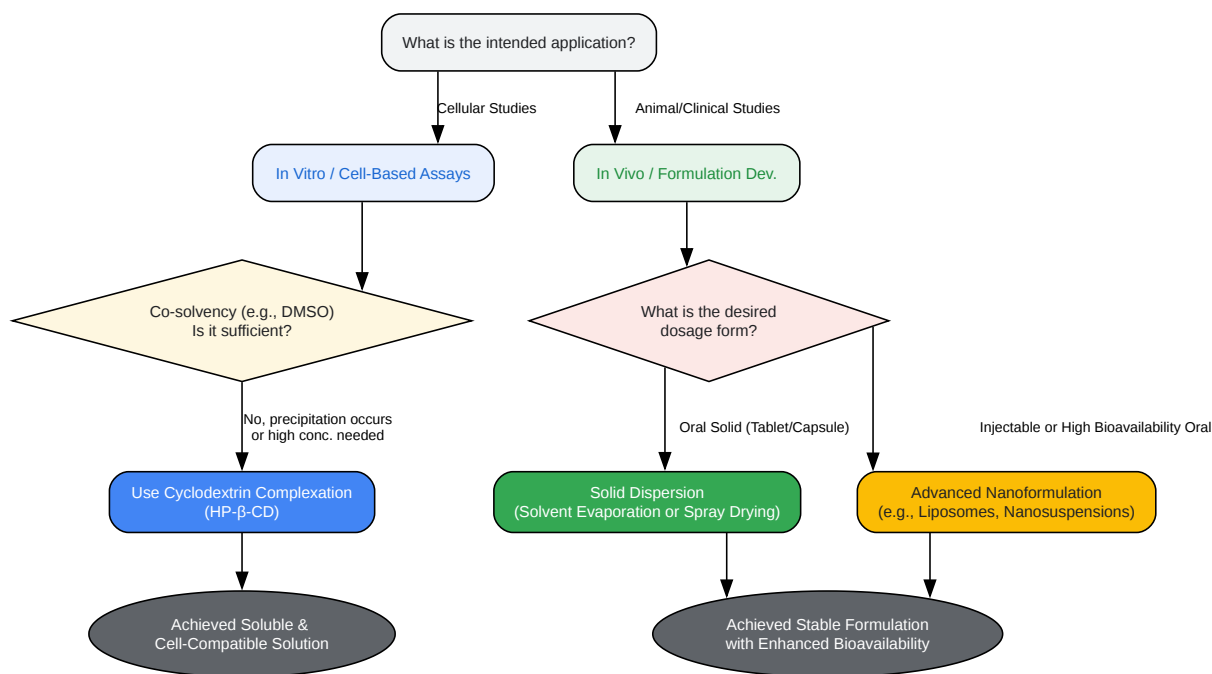

[Click to download full resolution via product page](#)

Caption: Decision tree for selecting a **boldoside** solubility enhancement method.

## Section 4: In-Depth Solubility Enhancement Protocols

### Method 1: Complexation with Hydroxypropyl-β-Cyclodextrin (HP-β-CD)

- Expertise & Causality: Cyclodextrins are cyclic oligosaccharides with a hydrophilic exterior and a hydrophobic inner cavity.[12] The hydrophobic **boldoside** molecule can be

encapsulated within this cavity, forming an "inclusion complex."[\[13\]](#) The hydrophilic outer surface of the cyclodextrin then interacts with water, effectively shuttling the **boldoside** into solution and keeping it stable. HP- $\beta$ -CD is widely used due to its high water solubility and excellent safety profile.[\[12\]](#)

This preliminary experiment is crucial to determine the stoichiometry (e.g., 1:1 or 1:2) and stability constant of the **boldoside**:HP- $\beta$ -CD complex, validating that complexation is occurring.[\[14\]](#)

- Preparation: Prepare a series of aqueous solutions with increasing concentrations of HP- $\beta$ -CD (e.g., 0, 2, 4, 6, 8, 10 mM) in a suitable buffer (e.g., phosphate buffer, pH 7.4).
- Incubation: Add an excess amount of **boldoside** powder to each solution in separate sealed vials. Ensure there is undissolved solid at the bottom of each vial.
- Equilibration: Agitate the vials at a constant temperature (e.g., 25°C or 37°C) for 24-48 hours to ensure equilibrium is reached.
- Sampling & Analysis: After equilibration, allow the suspensions to settle. Filter the supernatant through a 0.22  $\mu$ m syringe filter to remove undissolved **boldoside**.
- Quantification: Dilute the filtered samples appropriately and quantify the concentration of dissolved **boldoside** using a validated HPLC-UV method.
- Data Plotting: Plot the concentration of dissolved **boldoside** (Y-axis) against the concentration of HP- $\beta$ -CD (X-axis). A linear plot (Type AL) suggests the formation of a soluble 1:1 complex.[\[14\]](#)[\[15\]](#)

This protocol uses the kneading method, which is effective for lab-scale preparations.[\[16\]](#)

- Molar Calculation: Determine the desired molar ratio (e.g., 1:1, based on phase solubility results). Weigh out the corresponding amounts of **boldoside** and HP- $\beta$ -CD.
- Kneading: Place the HP- $\beta$ -CD powder in a glass mortar. Add a small amount of a water/ethanol mixture (e.g., 50:50 v/v) to form a thick, uniform paste.

- **Incorporation:** Add the **boldoside** powder to the paste and knead thoroughly for 45-60 minutes. Add small amounts of the solvent mixture as needed to maintain a paste-like consistency.
- **Drying:** Scrape the paste into a glass dish and dry it under vacuum at 40-50°C until a constant weight is achieved.
- **Final Product:** The resulting dry powder is the **boldoside**-HP- $\beta$ -CD inclusion complex. It can be stored and dissolved directly in aqueous buffers or cell culture medium for your experiments.

## Method 2: Solid Dispersion via Solvent Evaporation

- **Expertise & Causality:** A solid dispersion involves dispersing the drug (**boldoside**) at a molecular level within a solid hydrophilic polymer matrix (carrier).[2][17] When this solid is introduced to an aqueous environment, the polymer dissolves rapidly, causing the drug to be released as very fine, amorphous particles. This high-energy amorphous state has a much higher apparent solubility and dissolution rate than the original crystalline form. Polyvinylpyrrolidone (PVP K30) is a commonly used carrier for this method.
- **Dissolution:** Weigh 100 mg of **boldoside** and 500 mg of PVP K30. Dissolve both components completely in a suitable common solvent, such as a mixture of dichloromethane and ethanol, in a round-bottom flask. Stir until a clear solution is obtained.
- **Evaporation:** Connect the flask to a rotary evaporator. Evaporate the solvent under reduced pressure at a controlled temperature (e.g., 40-50°C). Continue until a thin, solid film is formed on the inside of the flask.
- **Final Drying:** Place the flask in a vacuum oven at 40°C for at least 24 hours to remove any residual solvent.
- **Processing:** Scrape the solid material from the flask. Gently grind the resulting solid dispersion using a mortar and pestle to obtain a fine powder.
- **Storage:** Store the powder in a desiccator to protect it from moisture, which can cause the amorphous drug to recrystallize.

The success of these methods can be validated through various characterization techniques.

| Technique                                      | Purpose  | Expected Result for Successful Formulation  |
|--|--|---|
| Dissolution Study                              | Measures the rate and extent of drug release in an aqueous medium. | A significant increase in the dissolution rate and apparent solubility of boldoside from the complex/dispersion compared to the pure drug.  |
| Differential Scanning Calorimetry (DSC)        | Analyzes thermal transitions.                                      | The sharp melting point peak of crystalline boldoside will disappear or shift in the DSC thermogram of the solid dispersion, indicating its conversion to an amorphous state.[18]                             |
| Fourier-Transform Infrared (FTIR) Spectroscopy | Identifies chemical bonds and interactions.                        | Shifts or broadening of characteristic peaks (e.g., hydroxyl, carbonyl groups) of boldoside suggest interaction with the carrier (HP- $\beta$ -CD or PVP), confirming complexation or dispersion.[19][20][21] |
| Powder X-Ray Diffraction (PXRD)                | Differentiates between crystalline and amorphous forms.            | The sharp diffraction peaks characteristic of crystalline boldoside will be absent in the PXRD pattern of the amorphous solid dispersion.<br>[18]   |

## Section 5: Analytical Method for Solubility Quantification

A reliable analytical method is non-negotiable for accurate solubility determination. A validated High-Performance Liquid Chromatography (HPLC) with UV detection is the gold standard.

## HPLC-UV Method Parameters (Example)

- Column: C18 reversed-phase column (e.g., 250 mm x 4.6 mm, 5  $\mu$ m particle size).
- Mobile Phase: Isocratic or gradient elution using a mixture of an acidified aqueous solvent (e.g., water with 0.1% phosphoric acid) and an organic solvent (e.g., acetonitrile or methanol).[22]
- Flow Rate: 1.0 mL/min.
- Detection Wavelength: Determined by scanning the UV spectrum of **boldoside** to find its maximum absorbance ( $\lambda_{max}$ ), likely in the 254-370 nm range typical for flavonoids.
- Validation: The method must be validated according to ICH guidelines for linearity, accuracy, precision, limit of detection (LOD), and limit of quantification (LOQ).[22][23] A good linear relationship ( $r^2 > 0.999$ ) should be established over a relevant concentration range.

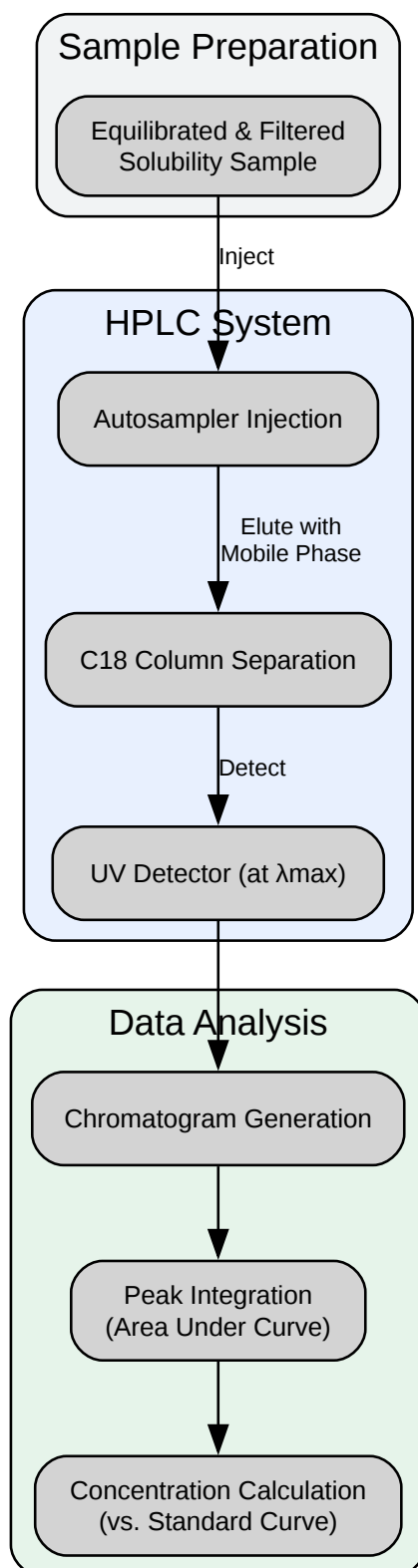

[Click to download full resolution via product page](#)

Caption: Workflow for quantifying **boldoside** concentration using HPLC-UV.

## References

- Title: Inclusion complex formation of cyclodextrin with its guest and their applications Source: Open Access Text URL:[[Link](#)]
- Title: Preparation and Properties of Cyclodextrin Inclusion Complexes of Hyperoside Source: Molecules (MDPI) URL:[[Link](#)]
- Title: Preparation and Evaluation of Solid Dispersions of A New Antitumor Compound Based on Early-Stage Preparation Discovery Concept Source: Pharmaceutical Research (Springer) URL:[[Link](#)]
- Title: Cyclodextrin Inclusion Complex Formation and Solid-State Characterization of the Natural Antioxidants  $\alpha$ -Tocopherol and Quercetin Source: Journal of Agricultural and Food Chemistry (ACS Publications) URL:[[Link](#)]
- Title: Review on Manufacturing Methods of Solid Dispersion Technology for Enhancing the Solubility of Poorly Water Source: Journal of Advancement in Pharmacology URL:[[Link](#)]
- Title: Phase solubility studies of BCP with M $\beta$ CD and 2-hydroxypropyl- $\beta$ -cyclodextrin (HP $\beta$ CD) Source: ResearchGate URL:[[Link](#)]
- Title: Evaluation of some Methods for Preparing Gliclazide-  $\beta$ -Cyclodextrin Inclusion Complexes Source: Tropical Journal of Pharmaceutical Research URL:[[Link](#)]
- Title: Solubility of Flavonoids in Organic Solvents Source: Journal of Chemical & Engineering Data (ACS Publications) URL:[[Link](#)]
- Title: Extraction of Flavonoids From Natural Sources Using Modern Techniques Source: Frontiers in Plant Science URL:[[Link](#)]
- Title: Cyclodextrin-Based Delivery Systems for Flavonoids: Mechanisms, Advances, Formulation, and Application Opportunities Source: Pharmaceutics (MDPI) URL:[[Link](#)]
- Title: Study of Flavonoid/Hydroxypropyl- $\beta$ -Cyclodextrin Inclusion Complexes by UV-Vis, FT-IR, DSC, and X-Ray Diffraction Analysis Source: Journal of Spectroscopy URL:[[Link](#)]

- Title: Validation of the Analytical Method for the Determination of Flavonoids in Broccoli  
Source: ResearchGate URL:[[Link](#)]
- Title: What the concentration of DMSO you use in cell culture assays? Source:  
ResearchGate URL:[[Link](#)]
- Title: Dissolution Testing for Poorly Soluble Drugs: A Continuing Perspective Source:  
Pharmaceutical Technology URL:[[Link](#)]
- Title: Principal Component Analysis Application on Flavonoids Characterization Source:  
ResearchGate URL:[[Link](#)]
- Title: Effect of pH on the Stability of Plant Phenolic Compounds Source: ResearchGate URL:  
[[Link](#)]
- Title: My samples turned cloudy while colorimetry (for total flavonoid content determination).  
Source: ResearchGate URL:[[Link](#)]
- Title: Quercetin/ $\beta$ -Cyclodextrin Solid Complexes Prepared in Aqueous Solution Followed by  
Spray-drying or by Physical Mixture Source: AAPS PharmSciTech (Springer) URL:[[Link](#)]
- Title: Characterization and Discrimination of Pure Standards of Phenolic Compounds Using  
FTIR Spectroscopy in the Terahertz Range Source: Molecules (MDPI) URL:[[Link](#)]
- Title: Dimethyl sulfoxide affects the viability and mineralization activity of apical papilla cells  
in vitro Source: Journal of Applied Oral Science URL:[[Link](#)]
- Title: HPLC Analysis of Phenolic Compounds and Flavonoids with Overlapping Peaks  
Source: NIH National Library of Medicine URL:[[Link](#)]
- Title: Method of preparing solid dispersions Source: Google Patents URL
- Title: Effects of pH on the ability of flavonoids to act as Pickering emulsion stabilizers Source:  
Colloids and Surfaces B: Biointerfaces URL:[[Link](#)]
- Title: Dissolution Method Development for Poorly Soluble Compounds Source:  
ResearchGate URL:[[Link](#)]

- Title: Degradation of Flavonoid Glycosides and Aglycones During in vitro Fermentation with Human Faecal Flora Source: ResearchGate URL:[[Link](#)]
- Title: Water-soluble flavonoid composition and production method thereof Source: Google Patents URL
- Title: Solubility and Modeling of Hesperidin in Cosolvent Mixtures of Ethanol, Isopropanol, Propylene Glycol, and n-Propanol + Water Source: ResearchGate URL:[[Link](#)]
- Title: Enhancement of flavonols water solubility by cyclodextrin inclusion complex formation - case study Source: ResearchGate URL:[[Link](#)]
- Title: Development and validation of analytical method by spectrophotometry UV-Vis for quantification of flavonoids in leaves of Senna occidentalis Link Source: Research, Society and Development URL:[[Link](#)]
- Title: Analysis of FTIR Spectra, Flavonoid Content and Anti-Tyrosinase Activity of Extracts and Lotion from Garcinia schomburgkiana by Multivariate Method Source: Trends in Sciences URL:[[Link](#)]
- Title: Bioavailability Enhancement Techniques for Poorly Aqueous Soluble Drugs and Therapeutics Source: Pharmaceuticals (MDPI) URL:[[Link](#)]
- Title: Solid Dispersion of Lumefantrine Using Soluplus® by Solvent Evaporation Method Source: ResearchGate URL:[[Link](#)]
- Title: High-Performance Liquid Chromatography (HPLC) Method Validation for Simultaneous Quantitation of Five Phytoestrogenic Flavonoids Source: Philippine Journal of Science URL: [[Link](#)]
- Title: Different Methods Used In Solid Dispersion Source: IOSR Journal of Pharmacy URL: [[Link](#)]
- Title: Enrichment of the flavonoid fraction from Eucommia ulmoides leaves by a liquid antisolvent precipitation method Source: RSC Advances URL:[[Link](#)]
- Title: Microwave-Assisted Solid–Liquid Extraction Using Propylene Glycol as a Solvent Source: Applied Sciences (MDPI) URL:[[Link](#)]

- Title: Analysis of Flavonoid in Medicinal Plant Extract Using Infrared Spectroscopy and Chemometrics Source: International Journal of Analytical Chemistry URL:[[Link](#)]
- Title: Coloration of Flowers by Flavonoids and Consequences of pH Dependent Absorption Source: Frontiers in Plant Science URL:[[Link](#)]
- Title: DMSO usage in cell culture Source: LifeTein URL:[[Link](#)]
- Title: Rapid Prediction of Fig Phenolic Acids and Flavonoids Using Mid-Infrared Spectroscopy Source: Frontiers in Nutrition URL:[[Link](#)]
- Title: Effect of pH on the chemical modification of quercetin and structurally related flavonoids Source: RSC Advances URL:[[Link](#)]
- Title: Methods of increasing solubility of poorly soluble compounds and methods of making and using formulations Source: Google Patents URL
- Title: Evaluation of the Drug–Polymer Compatibility and Dissolution Behaviour of Fenbendazole–Soluplus® Solid Dispersions Source: Pharmaceutics (MDPI) URL:[[Link](#)]
- Title: What is maximum allowable concentration of DMSO as solvent for drugs to check activity on animal cell lines? Source: ResearchGate URL:[[Link](#)]
- Title: Content determination of the flavonoids in the different parts and different species of Abelmoschus esculentus L. Source: NIH National Library of Medicine URL:[[Link](#)]
- Title: Determination and validation of spectrophotometric analytical method for quantification of total flavonoids Source: Research, Society and Development URL:[[Link](#)]

### Need Custom Synthesis?

BenchChem offers custom synthesis for rare earth carbides and specific isotopic labeling.

Email: [info@benchchem.com](mailto:info@benchchem.com) or [Request Quote Online](#).

## Sources

- [1. reddit.com \[reddit.com\]](#)

- [2. Preparation and Evaluation of Solid Dispersions of A New Antitumor Compound Based on Early-Stage Preparation Discovery Concept - PMC \[pmc.ncbi.nlm.nih.gov\]](#)
- [3. utoronto.scholaris.ca \[utoronto.scholaris.ca\]](#)
- [4. researchgate.net \[researchgate.net\]](#)
- [5. Dimethyl sulfoxide affects the viability and mineralization activity of apical papilla cells in vitro - PMC \[pmc.ncbi.nlm.nih.gov\]](#)
- [6. lifetein.com \[lifetein.com\]](#)
- [7. researchgate.net \[researchgate.net\]](#)
- [8. Coloration of Flowers by Flavonoids and Consequences of pH Dependent Absorption - PMC \[pmc.ncbi.nlm.nih.gov\]](#)
- [9. Effects of pH on the ability of flavonoids to act as Pickering emulsion stabilizers - PubMed \[pubmed.ncbi.nlm.nih.gov\]](#)
- [10. researchgate.net \[researchgate.net\]](#)
- [11. Effect of pH on the chemical modification of quercetin and structurally related flavonoids characterized by optical \(UV-visible and Raman\) spectroscopy - Physical Chemistry Chemical Physics \(RSC Publishing\) \[pubs.rsc.org\]](#)
- [12. Study of Flavonoid/Hydroxypropyl- \$\beta\$ -Cyclodextrin Inclusion Complexes by UV-Vis, FT-IR, DSC, and X-Ray Diffraction Analysis - PMC \[pmc.ncbi.nlm.nih.gov\]](#)
- [13. Preparation and Properties of Cyclodextrin Inclusion Complexes of Hyperoside - PMC \[pmc.ncbi.nlm.nih.gov\]](#)
- [14. Quercetin/ \$\beta\$ -Cyclodextrin Solid Complexes Prepared in Aqueous Solution Followed by Spray-drying or by Physical Mixture - PMC \[pmc.ncbi.nlm.nih.gov\]](#)
- [15. mdpi.com \[mdpi.com\]](#)
- [16. oatext.com \[oatext.com\]](#)
- [17. crsubscription.com \[crsubscription.com\]](#)
- [18. researchgate.net \[researchgate.net\]](#)
- [19. researchgate.net \[researchgate.net\]](#)
- [20. mdpi.com \[mdpi.com\]](#)
- [21. Analysis of FTIR Spectra, Flavonoid Content and Anti-Tyrosinase Activity of Extracts and Lotion from \*Garcinia schomburgkiana\* by Multivariate Method | Trends in Sciences \[tis.wu.ac.th\]](#)
- [22. researchgate.net \[researchgate.net\]](#)

- [23. scienggj.org \[scienggj.org\]](https://www.scienggj.org)
- To cite this document: BenchChem. [Technical Support Center: A Scientist's Guide to Boldoside Solubility Enhancement]. BenchChem, [2026]. [Online PDF]. Available at: [<https://www.benchchem.com/product/b579224/docs#technical-support-center-a-scientist-s-guide-to-boldoside-solubility-enhancement>]

---

### Disclaimer & Data Validity:

The information provided in this document is for Research Use Only (RUO) and is strictly not intended for diagnostic or therapeutic procedures. While BenchChem strives to provide accurate protocols, we make no warranties, express or implied, regarding the fitness of this product for every specific experimental setup.

**Technical Support:** The protocols provided are for reference purposes. Unsure if this reagent suits your experiment?

**Need Industrial/Bulk Grade?** [Request Custom Synthesis Quote](#)

## BenchChem

Our mission is to be the trusted global source of essential and advanced chemicals, empowering scientists and researchers to drive progress in science and industry.

### Contact

Address: 3281 E Guasti Rd

Ontario, CA 91761, United States

Phone: (601) 213-4426

Email: [info@benchchem.com](mailto:info@benchchem.com)

[Contact our Ph.D. Support Team for a compatibility check](#)