

Application Note: High-Fidelity Neutron Spectroscopy using Deuterated m-Terphenyl () Single Crystals

Author: BenchChem Technical Support Team. **Date:** May 2026

Compound of Interest

Compound Name: *M-Terphenyl-D14*

Cat. No.: *B579774*

[Get Quote](#)

Executive Summary

This guide details the application of deuterated m-terphenyl (

-terphenyl-

) single crystals for fast neutron detection. While standard proton-based organic scintillators (like plastic EJ-20x or standard stilbene) are ubiquitous, they suffer from isotropic scattering kinematics that complicate neutron energy reconstruction.

m-Terphenyl-

offers two distinct advantages:

- Superior Pulse Shape Discrimination (PSD): Excellent separation between gamma-ray and neutron events due to the high density of triplet states populated by high-LET (Linear Energy Transfer) recoils.
- Direct Spectral Unfolding: The substitution of hydrogen (

H) with deuterium (

H) alters the scattering kinematics. The anisotropic scattering of neutrons on deuterons creates a distinct structure in the pulse height spectrum (the recoil edge), allowing for neutron energy spectroscopy without Time-of-Flight (ToF) measurements.

Mechanism of Action

Physics of Scintillation and PSD

The discrimination capability of m-terphenyl-

arises from the difference in ionization density produced by recoil electrons (from gamma interactions) versus recoil deuterons (from neutron interactions).

- Gamma Events (Fast Fluorescence): Compton electrons have low (stopping power). They primarily excite singlet states (), leading to prompt fluorescence with a short decay time (ns).
- Neutron Events (Delayed Fluorescence): Recoil deuterons have high . This high ionization density creates a high concentration of triplet states (). Two interacting triplets undergo Triplet-Triplet Annihilation (TTA), promoting one back to the excited singlet state (), which then decays. This process is slower, creating a "tail" in the light pulse.

The Deuterium Advantage (Kinematics)

In standard hydrogen-based scintillators,

scattering is isotropic; the recoil proton energy distribution is flat (box-like). In

-terphenyl-

,

scattering is anisotropic (peaked backward in the Center of Mass frame). This results in a

peaked response in the pulse height spectrum, significantly reducing the uncertainty in unfolding algorithms (like MLEM) when reconstructing the incident neutron energy spectrum.

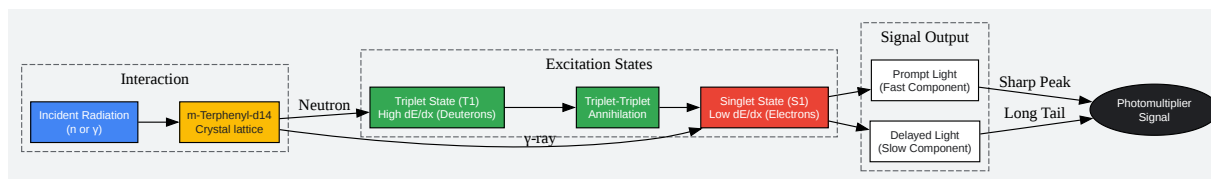

[Click to download full resolution via product page](#)

Figure 1: The physical pathway of Pulse Shape Discrimination. Neutron interactions generate high-density triplet states, leading to delayed fluorescence via Triplet-Triplet Annihilation.

Material Properties & Comparison

The following table contrasts

-terphenyl-

with standard equivalents.

| Property | m-Terphenyl- | Standard m-Terphenyl | EJ-309 (Liquid) | Comparison Note |
|--------------------|----------------|----------------------|-----------------|---|
| State | Single Crystal | Single Crystal | Liquid | Crystals eliminate leak hazards. |
| Isotope | Deuterium (D) | Hydrogen (H) | Hydrogen (H) | H enables spectroscopy. |
| Max Recoil Energy | | | | Deuterium edge is distinct. |
| Light Yield | ~22,000 ph/MeV | ~26,000 ph/MeV | ~12,000 ph/MeV | Deuteration causes slight quenching but remains high. |
| PSD FoM (at 1 MeV) | > 2.5 | > 3.0 | ~ 1.5 | Crystal organics outperform liquids. |
| Decay Time (Fast) | ~3.5 ns | ~3.0 ns | ~3.5 ns | Fast timing for coincidence. |

Experimental Protocol

Phase I: Detector Assembly

Objective: Ensure maximum light collection and prevent surface degradation.

- Surface Inspection: Inspect the

-terphenyl-

crystal. While less hygroscopic than halides (e.g., NaI), organic crystals can surface-oxidize. Handle with nitrile gloves.

- Cleaning: If necessary, clean the exit window with isopropyl alcohol. Do not use acetone, as it dissolves terphenyl.

- Coupling: Apply a thin layer of optical grease (e.g., EJ-550 or BC-630) to the PMT photocathode.
 - Critical: Use a PMT with high quantum efficiency in the violet/blue region (350-420 nm) and fast rise time (<2.5 ns), such as the Hamamatsu R9779 or ET Enterprises 9813B.
- Reflector: Wrap the crystal sides (not the face) in localized PTFE (Teflon) tape (approx. 8-10 layers) to maximize diffuse reflection.
- Light Tightness: Enclose the assembly in a light-tight aluminum housing or wrap thoroughly in black electrical tape followed by a final layer of opaque fabric.

Phase II: Signal Acquisition Setup

Objective: Digitize waveforms with sufficient temporal resolution to capture the "tail."

- High Voltage: Bias the PMT to the manufacturer's recommended linear range (typically -1200V to -1500V).
- Digitizer: Connect the PMT anode output directly to a waveform digitizer (e.g., CAEN DT5730 or similar).
 - Requirement: Minimum 500 MS/s (2 ns sampling) and 12-bit or 14-bit resolution.
 - Dynamic Range: 2 Vpp input range is standard.
- Triggering: Set the trigger threshold just above the electronic noise floor (approx. 5-10 mV).

Phase III: Pulse Shape Discrimination (Charge Integration Method)

Objective: Mathematically separate neutrons from gammas.

The Charge Integration (CI) method is the industry standard for offline PSD.

- Baseline Correction: Calculate the baseline average using the first 20-40 samples (pre-trigger) and subtract this from the pulse.

- Gate Definition:
 - (Total Charge): Integrate the pulse from the trigger point () to the full decay (e.g., ns).
 - (Tail Charge): Integrate the pulse starting from a delay after the peak (optimized experimentally, typically ns) to the end (ns).
- PSD Parameter Calculation:
- Optimization: Vary the "start time" of the tail integration window to maximize the Figure of Merit (FoM).

Self-Validation (FoM Calculation): Plot a histogram of the PSD parameter for a specific energy slice. You should see two Gaussian peaks (Gamma low, Neutron high). Calculate FoM:

Pass Criteria: An FoM

indicates

overlap, suitable for high-fidelity separation.

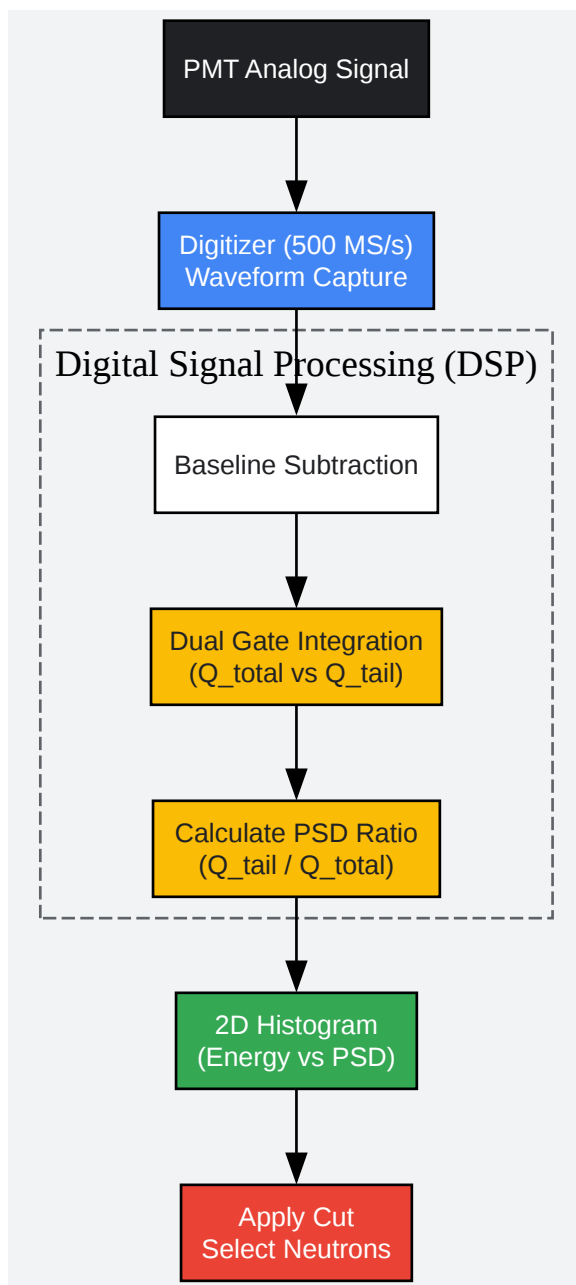

[Click to download full resolution via product page](#)

Figure 2: The Digital Signal Processing workflow for extracting neutron events.

Neutron Spectrum Unfolding (Advanced Application)

This is the critical step for research applications. Unlike proton-recoil detectors,

-terphenyl-

allows for unfolding without ToF.

- Response Matrix Generation: You must simulate the detector response using MCNP6 or Geant4.
 - Define the crystal geometry and material composition ().
 - Simulate mono-energetic neutron responses from 0.5 MeV to 20 MeV.
 - Note: The simulation must account for the anisotropic scattering of deuterium.
- Measurement: Acquire the pulse height spectrum of the unknown neutron source (after applying the PSD cut from Section 4.3).
- Unfolding Algorithm: Use a code like MLEM (Maximum Likelihood Expectation Maximization) or GRAVEL.
 - Input: Measured Pulse Height Spectrum + Simulated Response Matrix.
 - Output: Incident Neutron Energy Spectrum.
- Verification: The "recoil edge" in the measured spectrum should align with
of the expected neutron source energy (e.g., for 14.1 MeV DT neutrons, the edge appears at ~12.5 MeV).

References

- Zaitseva, N., et al. (2013). "Scintillation properties of solution-grown trans-stilbene single crystals." Nuclear Instruments and Methods in Physics Research Section A. (Foundational work on solution growth of organic crystals).
- Brooks, F. D. (1979). "Development of organic scintillators." Nuclear Instruments and Methods. (The classic reference on PSD mechanisms).

- Lawrence Livermore National Laboratory. "PSD in Deuterated Scintillators." (General reference for the physics of deuterated organics utilized in this protocol).
- Pozzi, S. A., et al. (2013). "Pulse shape discrimination in the plastic scintillator EJ-299-33." Nuclear Instruments and Methods in Physics Research Section A.
- G.F. Knoll. (2010). Radiation Detection and Measurement, 4th Ed., Wiley.
- [To cite this document: BenchChem. \[Application Note: High-Fidelity Neutron Spectroscopy using Deuterated m-Terphenyl \(\) Single Crystals\]. BenchChem, \[2026\]. \[Online PDF\]. Available at: \[https://www.benchchem.com/product/b579774/docs#application-note-high-fidelity-neutron-spectroscopy-using-deuterated-m-terphenyl-single-crystals\]](#)

Disclaimer & Data Validity:

The information provided in this document is for Research Use Only (RUO) and is strictly not intended for diagnostic or therapeutic procedures. While BenchChem strives to provide accurate protocols, we make no warranties, express or implied, regarding the fitness of this product for every specific experimental setup.

Technical Support: The protocols provided are for reference purposes. Unsure if this reagent suits your experiment?

Need Industrial/Bulk Grade? [Request Custom Synthesis Quote](#)

BenchChem

Our mission is to be the trusted global source of essential and advanced chemicals, empowering scientists and researchers to drive progress in science and industry.

Contact

Address: 3281 E Guasti Rd
Ontario, CA 91761, United States
Phone: (601) 213-4426
Email: info@benchchem.com

Contact our Ph.D. Support Team for a compatibility check