

Technical Support Center: Interpreting Complex NMR Spectra of Substituted Nicotinic Acids

Author: BenchChem Technical Support Team. **Date:** May 2026

Compound of Interest

Compound Name: Ethyl 5-chloro-2-hydroxynicotinate

CAS No.: 1214366-84-3

Cat. No.: B578153

[Get Quote](#)

Welcome to the technical support center for navigating the complexities of Nuclear Magnetic Resonance (NMR) spectroscopy of substituted nicotinic acids. This guide is designed for researchers, scientists, and drug development professionals who encounter challenges in spectral interpretation. Here, we address specific issues in a practical question-and-answer format, grounded in fundamental principles and advanced analytical techniques.

Frequently Asked Questions (FAQs) & Troubleshooting Guides

Issue 1: Severe Peak Overlap in the Aromatic Region

Question: My ¹H NMR spectrum of a disubstituted nicotinic acid shows a crowded, unresolvable multiplet in the aromatic region (typically 7.0-9.0 ppm). How can I confidently assign the proton signals?

Answer: This is a classic challenge with substituted pyridine rings due to the similar electronic environments of the remaining protons. The nitrogen atom's influence and the electronic effects

of substituents create a congested spectral region. Here's a systematic approach to deconstruct this complexity:

Causality: The nitrogen atom in the pyridine ring is electron-withdrawing, which generally deshields all ring protons compared to benzene.[1] Substituents further modulate these chemical shifts. Electron-donating groups will shield (move upfield), while electron-withdrawing groups will further deshield (move downfield). The interplay of these effects often results in small differences in chemical shifts, leading to overlapping signals.

Troubleshooting Protocol:

- Optimize 1D NMR Acquisition:
 - Increase Magnetic Field Strength: If available, acquiring the spectrum on a higher field instrument (e.g., 600 MHz vs. 400 MHz) will increase the dispersion of the signals, potentially resolving the overlap.
 - Optimize Shimming: Poor shimming can lead to broad peaks, exacerbating overlap. Ensure the instrument is well-shimmed to achieve the best possible resolution.[2]
- Leverage Solvent Effects:
 - Changing the NMR solvent can induce differential shifts in proton resonances, often resolving overlaps.[2][3] Aromatic solvents like benzene-d6 can cause significant upfield or downfield shifts due to anisotropic effects, where the solvent molecules arrange themselves specifically around the analyte.[2] Protic solvents like methanol-d4 can also alter chemical shifts through hydrogen bonding.[3]
 - Experiment: Acquire spectra in a non-polar solvent (e.g., CDCl3), a polar aprotic solvent (e.g., DMSO-d6), and an aromatic solvent (e.g., C6D6). Compare the aromatic regions to identify changes in peak positions.
- Employ 2D NMR Techniques: When 1D methods are insufficient, 2D NMR is the definitive solution.
 - COSY (Correlation Spectroscopy): This experiment identifies protons that are scalar (J) coupled, typically those on adjacent carbons (vicinal coupling).[4] A cross-peak in a COSY

spectrum indicates that the two protons are coupled. This is invaluable for tracing the connectivity of the protons around the pyridine ring.[5]

- TOCSY (Total Correlation Spectroscopy): This is an extension of COSY that shows correlations between all protons within a spin system, not just immediate neighbors.[6] For a nicotinic acid derivative, this can help identify all protons belonging to the pyridine ring in a single experiment.
- HSQC (Heteronuclear Single Quantum Coherence): This experiment correlates protons with their directly attached carbons.[4] It's a powerful tool for assigning proton signals if the carbon signals can be predicted or assigned.
- HMBC (Heteronuclear Multiple Bond Correlation): This experiment shows correlations between protons and carbons over two or three bonds.[7] This is crucial for connecting different fragments of the molecule and for assigning quaternary carbons (carbons with no attached protons).

Workflow for Resolving Peak Overlap:

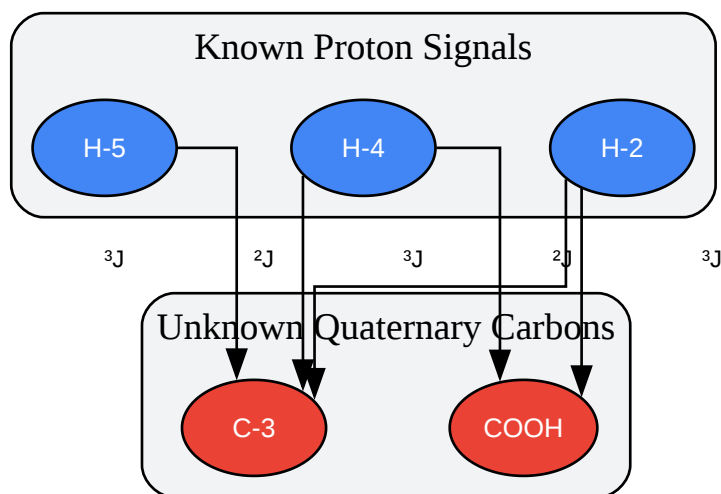
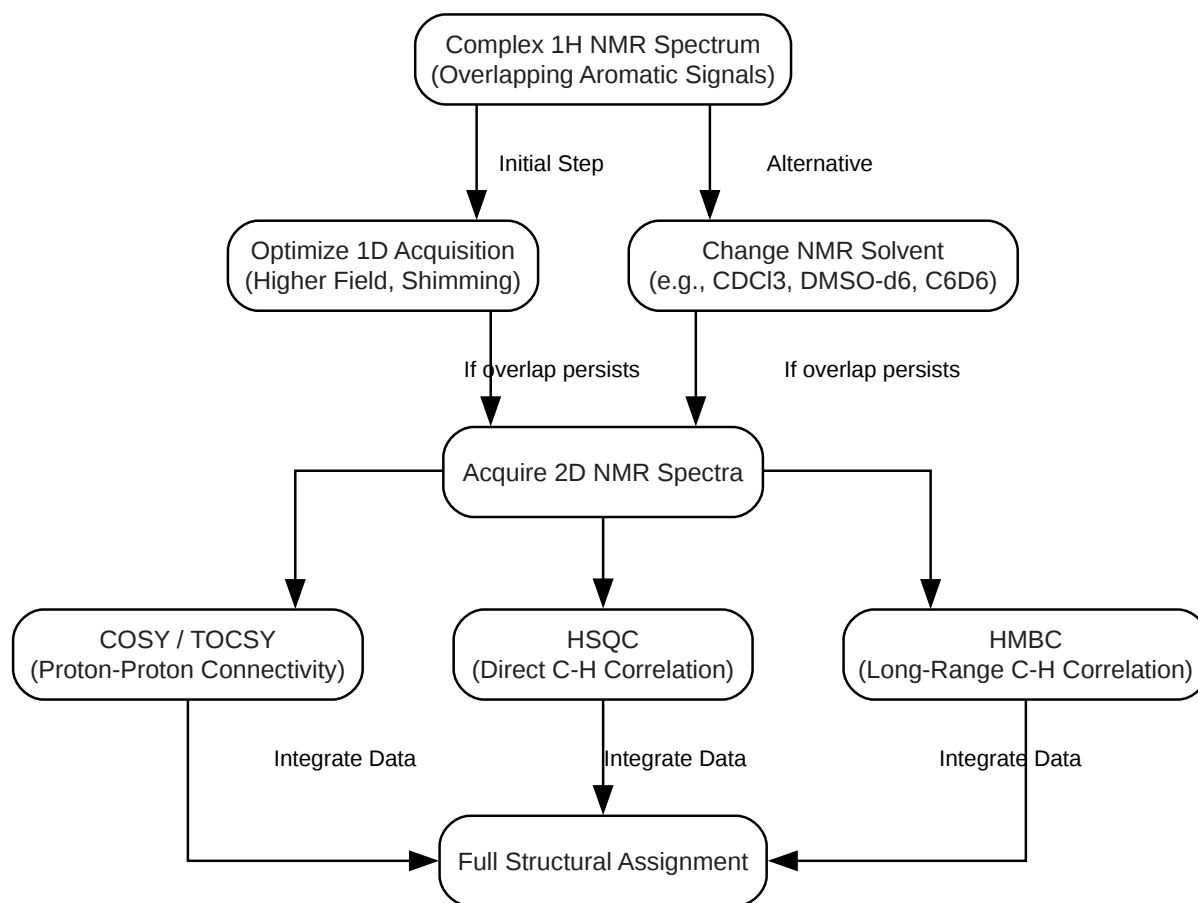

[Click to download full resolution via product page](#)

Caption: HMBC correlations for assigning quaternary carbons.

By systematically applying these troubleshooting strategies and advanced NMR techniques, you can overcome the inherent complexities in the spectra of substituted nicotinic acids and achieve unambiguous structural elucidation.

References

- Danil de Namor, A. F., et al. (2004). Solvent effect on the ^1H NMR spectra of a pyridinocalix(4)arene derivative and its protonation constants in methanol. SciELO Argentina. Available at: [\[Link\]](#)
- University of Rochester. Troubleshooting ^1H NMR Spectroscopy. Department of Chemistry. Available at: [\[Link\]](#)
- Chemistry Stack Exchange. (2017). Proton NMR Spectrum for Nicotinic Acid. Available at: [\[Link\]](#)
- Creative Biostructure. (2025). Understanding 2D NMR Spectra: How to Read and Interpret Them. Available at: [\[Link\]](#)
- Piretes, V., et al. (2005). NMR Study of the Influence of pH on the Persistence of Some Neonicotinoids in Water. Journal of the Serbian Chemical Society. Available at: [\[Link\]](#)
- Emery Pharma. (2018). A Step-By-Step Guide to 1D and 2D NMR Interpretation. Available at: [\[Link\]](#)
- Chemistry LibreTexts. (2023). 7.6: Interpreting 2-D NMR Spectra. Available at: [\[Link\]](#)
- YouTube. (2020). 2D NMR Spectroscopy: COSY, HSQC (HMQC) and HMBC. Organic Chemistry Explained. Available at: [\[Link\]](#)
- MDPI. (2002). Synthesis of Substituted 2-Pyridyl-4-phenylquinolines. Molecules. Available at: [\[Link\]](#)
- ESA-IPB. Advanced NMR techniques for structural characterization of heterocyclic structures. Available at: [\[Link\]](#)
- Wiley Online Library. (2025). NMR-Based Structural Analysis of Highly Substituted Pyridines From Kondrat'eva Aza-Diels–Alder Cycloadditions. Magnetic Resonance in Chemistry.

Available at: [\[Link\]](#)

- ACS Publications. (2024). Determination of Nicotine Protonation State in E-Liquids by Low-Resolution Benchtop NMR Spectroscopy. Chemical Research in Toxicology. Available at: [\[Link\]](#)
- Chemistry Stack Exchange. (2014). Proton NMR signals and rings. Available at: [\[Link\]](#)

Need Custom Synthesis?

BenchChem offers custom synthesis for rare earth carbides and specific isotopic labeling.

Email: info@benchchem.com or [Request Quote Online](#).

Sources

- 1. chemistry.stackexchange.com [chemistry.stackexchange.com]
- 2. [Troubleshooting](https://chem.rochester.edu) [chem.rochester.edu]
- 3. Solvent effect on the ^1H NMR spectra of a pyridinocalix(4)arene derivative and its protonation constants in methanol [scielo.org.ar]
- 4. creative-biostructure.com [creative-biostructure.com]
- 5. mdpi.com [mdpi.com]
- 6. sites.esa.ipb.pt [sites.esa.ipb.pt]
- 7. emerypharma.com [emerypharma.com]
- To cite this document: BenchChem. [Technical Support Center: Interpreting Complex NMR Spectra of Substituted Nicotinic Acids]. BenchChem, [2026]. [Online PDF]. Available at: [\[https://www.benchchem.com/product/b578153/docs#technical-support-center-interpreting-complex-nmr-spectra-of-substituted-nicotinic-acids\]](https://www.benchchem.com/product/b578153/docs#technical-support-center-interpreting-complex-nmr-spectra-of-substituted-nicotinic-acids)

Disclaimer & Data Validity:

The information provided in this document is for Research Use Only (RUO) and is strictly not intended for diagnostic or therapeutic procedures. While BenchChem strives to provide accurate protocols, we make no warranties, express or implied, regarding the fitness of this product for every specific experimental setup.

Technical Support: The protocols provided are for reference purposes. Unsure if this reagent suits your experiment?

Need Industrial/Bulk Grade? [Request Custom Synthesis Quote](#)

BenchChem

Our mission is to be the trusted global source of essential and advanced chemicals, empowering scientists and researchers to drive progress in science and industry.

Contact

Address: 3281 E Guasti Rd
Ontario, CA 91761, United States
Phone: (601) 213-4426
Email: info@benchchem.com

[Contact our Ph.D. Support Team for a compatibility check](#)