

Technical Guide: Spectroscopic Differentiation of Pyrazole Isomers

Author: BenchChem Technical Support Team. **Date:** May 2026

Compound of Interest

Compound Name: *1-(Cyclopropylmethyl)-1H-pyrazole*

CAS No.: 1344382-51-9

Cat. No.: B578091

[Get Quote](#)

Executive Summary

In medicinal chemistry, the pyrazole ring is a privileged scaffold, present in blockbuster drugs like Celecoxib (Celebrex) and Rimonabant.[1] However, the synthesis of pyrazoles—typically via the condensation of hydrazines with 1,3-diketones—often yields a mixture of regioisomers (1,3-disubstituted vs. 1,5-disubstituted).[1] Furthermore,

-unsubstituted pyrazoles exhibit annular tautomerism, rendering the 3- and 5-positions chemically equivalent on the NMR timescale.[1]

Misidentifying these isomers leads to erroneous Structure-Activity Relationship (SAR) data and potential patent invalidation.[1] This guide provides a definitive, data-driven workflow to distinguishing pyrazole isomers using NMR (

H,

C,

N), Mass Spectrometry, and X-ray crystallography.[1]

The Tautomerism Challenge (-Unsubstituted Pyrazoles)

Before analyzing fixed regioisomers, one must understand the behavior of the parent ring.[1]

-unsubstituted pyrazoles possess a mobile proton that oscillates between N1 and N2.[1][2]

The Phenomenon

In solution (e.g., DMSO-

or CDCl

), the proton exchange rate (

) is often faster than the NMR timescale.[1][3]

- Observation: The C3 and C5 carbons appear as a single, broad, averaged signal or two very broad humps.
- The "Acidification" Protocol: To resolve these signals, one must slow the exchange rate. Adding a trace of Trifluoroacetic acid (TFA) or cooling the sample (to -40°C) protonates the species or slows kinetics, freezing the tautomers and revealing distinct C3 and C5 peaks.[1]

Visualization: Annular Tautomerism

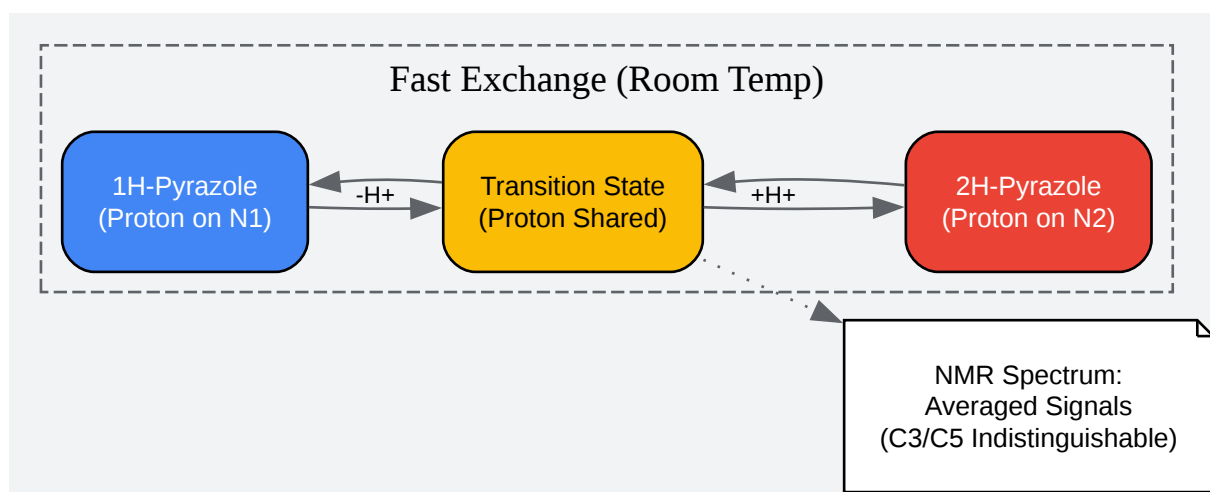

[Click to download full resolution via product page](#)

Figure 1: Mechanism of annular tautomerism leading to signal averaging in standard NMR.

Distinguishing -Substituted Regioisomers (1,3- vs. 1,5-)

When the nitrogen is substituted (e.g.,

-methyl,

-phenyl), the tautomerism is locked.[1] The challenge shifts to identifying whether the substituent on the carbon ring is adjacent to the substituted nitrogen (1,5-isomer) or distant (1,3-isomer).[1]

Method A: 1D NOE / 2D NOESY (The Gold Standard)

Nuclear Overhauser Effect (NOE) spectroscopy is the most reliable method for assignment.[1]

It relies on through-space magnetic interactions (distance < 5 Å).

- 1,5-Disubstituted Isomer: The

-substituent (e.g., N-CH

) is spatially crowded against the C5-substituent.[1] Result: Strong NOE cross-peak.

- 1,3-Disubstituted Isomer: The

-substituent is adjacent to the C5-proton.[1] Result: Strong NOE between

-substituent and H-5. No NOE to the C3-substituent.[1]

Method B: C NMR Chemical Shifts

Carbon chemical shifts provide corroborating evidence.[1][3][4][5] While substituent effects vary, general trends in azole chemistry (Cabildo/Claramunt datasets) hold true.

| Carbon Position | 1,3-Isomer (ppm) | 1,5-Isomer (ppm) | Mechanistic Rationale |
|-----------------|------------------|------------------|---|
| C3 | ~145 - 152 | ~135 - 140 | C3 is imine-like (C=N), generally more deshielded.[1] |
| C5 | ~105 - 130 | ~130 - 145 | C5 is enamine-like (C-N), generally more shielded, but steric compression in 1,5-isomers causes downfield shifts. |
| (Coupling) | Large (~170 Hz) | Smaller | Coupling to H4 varies significantly. |

Method C: N NMR (Gated Decoupling)

Nitrogen NMR is underutilized but definitive.[1]

- N1 (Pyrrole-type): More shielded (-150 to -200 ppm relative to nitromethane).[1]
- N2 (Pyridine-type): Deshielded (-60 to -100 ppm).[1]
- Differentiation: In 1,5-isomers, the steric clash often causes a shielding effect on N1 compared to the 1,3-isomer due to torsion of the N-substituent.

Experimental Workflow: The Decision Tree

Do not rely on a single technique. Use this self-validating protocol.



[Click to download full resolution via product page](#)

Figure 2: Standard Operating Procedure (SOP) for assigning pyrazole regioisomerism.

Advanced Characterization: Mass Spectrometry & X-Ray

While NMR is the primary tool for solution-state analysis, solid-state and fragmentation data provide necessary confirmation for regulatory filing.[1]

Mass Spectrometry (EI/ESI)

Isomers often share molecular ions

but differ in fragmentation stability.^[1]

- 1,5-Isomers: Often exhibit a dominant loss of the substituent at C5 due to steric relief ("Ortho-effect" analog).
- Fragmentation Pathway:
 - Loss of substituent (R).^[1]
 - Ring cleavage (loss of HCN).^[1]
 - Note: 1,3-isomers are generally thermodynamically more stable and may require higher collision energies (CID) to fragment compared to sterically strained 1,5-isomers.^[1]

X-Ray Crystallography

This is the absolute method for defining the solid-state tautomer.

- H-Bonding: Unsubstituted pyrazoles form trimeric or catemeric hydrogen-bonded chains in the crystal lattice.^[1]
- Bond Lengths: X-ray allows precise measurement of N1-C5 vs N1-N2 bond lengths, which differ slightly between isomers due to conjugation changes.

Comparative Data Summary

| Feature | 1,3-Disubstituted Pyrazole | 1,5-Disubstituted Pyrazole |
|-------------------------|-----------------------------------|--|
| Thermodynamic Stability | High (Less Steric Hindrance) | Lower (Steric Clash N1-R vs C5-R) |
| NOE Signal | N-R | N-R |
| | H5 (Strong) | C5-R (Strong) |
| C Shift (C3) | Deshielded (~150 ppm) | Deshielded (~140 ppm) |
| C Shift (C5) | Shielded (~105 ppm, if H) | Deshielded (~130+ ppm, if R) |
| Recrystallization | Often forms needles/plates easily | May require slower evaporation due to strain |

References

- Claramunt, R. M., et al. (2006).[1][6] Progress in Nuclear Magnetic Resonance Spectroscopy. "The use of NMR spectroscopy to study tautomerism." A foundational text on the dynamic equilibrium of azoles.
- Jimeno, M. L., et al. (2003).[1] New Journal of Chemistry. "¹H and ¹³C NMR study of perdeuterated pyrazoles." Provides specific chemical shift data and coupling constants for 3,5-substituted systems.
- Alkorta, I., et al. (2005).[1][5] Journal of Physical Organic Chemistry. "Theoretical study of molecular structure, IR and NMR spectra of pyrazolone and its derivatives." Discusses the theoretical basis for shift differences. [1]
- Foces-Foces, C., et al. (1992).[1] Journal of the Chemical Society, Perkin Transactions 2. "The Tautomerism of 3(5)-Phenylpyrazoles: An Experimental (¹H, ¹³C, ¹⁵N NMR and X-Ray Crystallography) Study." [1]
- Holzer, W., et al. (2008).[1] Magnetic Resonance in Chemistry. "¹³C and ¹⁵N NMR chemical shifts of 1-(2',4'-dinitrophenyl) and 1-(2',4',6'-trinitrophenyl) pyrazoles." Demonstrates the use of ¹⁵N for distinguishing sterically crowded pyrazoles.

Need Custom Synthesis?

BenchChem offers custom synthesis for rare earth carbides and specific isotopic labeling.

Email: info@benchchem.com or [Request Quote Online](#).

Sources

- [1. userpage.fu-berlin.de](http://userpage.fu-berlin.de) [userpage.fu-berlin.de]
- [2. mdpi.com](http://mdpi.com) [mdpi.com]
- [3. researchgate.net](http://researchgate.net) [researchgate.net]
- [4. mdpi.com](http://mdpi.com) [mdpi.com]
- [5. researchgate.net](http://researchgate.net) [researchgate.net]
- [6. researchgate.net](http://researchgate.net) [researchgate.net]
- To cite this document: BenchChem. [Technical Guide: Spectroscopic Differentiation of Pyrazole Isomers]. BenchChem, [2026]. [Online PDF]. Available at: [<https://www.benchchem.com/product/b578091/docs#technical-guide-spectroscopic-differentiation-of-pyrazole-isomers>]

Disclaimer & Data Validity:

The information provided in this document is for Research Use Only (RUO) and is strictly not intended for diagnostic or therapeutic procedures. While BenchChem strives to provide accurate protocols, we make no warranties, express or implied, regarding the fitness of this product for every specific experimental setup.

Technical Support: The protocols provided are for reference purposes. Unsure if this reagent suits your experiment?

Need Industrial/Bulk Grade? [Request Custom Synthesis Quote](#)

BenchChem

Our mission is to be the trusted global source of essential and advanced chemicals, empowering scientists and researchers to drive progress in science and industry.

Contact

Address: 3281 E Guasti Rd

Ontario, CA 91761, United States

Phone: (601) 213-4426

Email: info@benchchem.com

[Contact our Ph.D. Support Team for a compatibility check](#)