

Mitigating interference in the analytical determination of rubidium.

Author: BenchChem Technical Support Team. **Date:** May 2026

Compound of Interest

Compound Name: *Rubidium fluoride hydrate*

CAS No.: *16422-67-6*

Cat. No.: *B578940*

[Get Quote](#)

Technical Support Center: Rubidium (Rb) Analytical Determination

Topic: Mitigating Interference in the Analytical Determination of Rubidium ID: TS-RB-2024-V2

Status: Active Audience: Analytical Chemists, PK/PD Scientists, Geochemists

Introduction: The Physics of Rubidium Analysis

Rubidium (Rb) presents a dichotomy in analytical chemistry. In biological matrices, it acts as a potassium congener, often used in ion channel tracers or perfusion studies. In geological samples, it is the parent isotope for Rb-Sr dating.

The primary challenge in determining Rb is not sensitivity, but selectivity and ionization equilibrium.

- In Flame AAS/AES: Rb has a low ionization potential (4.177 eV). It ionizes too efficiently, reducing the population of ground-state atoms available to absorb light.

- In ICP-MS: The primary isotope
suffers from a direct isobaric overlap with
, rendering standard quantification impossible without reaction chemistry or mass shifting.

This guide provides modular troubleshooting workflows to isolate and neutralize these interferences.

Module 1: Atomic Absorption Spectroscopy (AAS)

Issue: Non-linear calibration and low sensitivity due to ionization.

The Mechanism: Ionization Equilibrium

In an air-acetylene flame (

), Rb exists in an equilibrium defined by the Saha equation:

Because Rb ionizes so easily (~75% ionization in standard flames), the signal for atomic absorption (

) is suppressed.^[1] If the sample matrix contains other easily ionizable elements (like K or Na), they donate electrons to the flame, shifting the equilibrium back to the left (Le Chatelier's principle) and artificially enhancing the Rb signal. This causes "Ionization Interference."^{[1][2]}

Protocol A-1: The Ionization Buffer System

Objective: Stabilize the electron density in the flame to ensure 100% of Rb remains in the ground state (

).

Reagents:

- Cesium Chloride (CsCl) or Cesium Nitrate (
-).
- Why Cs? Cesium has an even lower ionization potential (3.89 eV) than Rb. It acts as a "sacrificial lamb," ionizing completely to flood the flame with electrons.

Workflow:

- Preparation: Prepare a 10% (w/v) Cs stock solution.
- Dosing: Add Cs stock to all blanks, standards, and samples to achieve a final concentration of 0.2% (2000 ppm) Cs.
- Validation:
 - Measure the absorbance of a 5 ppm Rb standard without Cs.
 - Measure the absorbance of a 5 ppm Rb standard with Cs.
 - Pass Criteria: The signal with Cs must be significantly higher (typically 2-3x). If not, check flame stoichiometry (fuel-rich flames reduce ionization but increase noise).

Visual Logic: Ionization Suppression

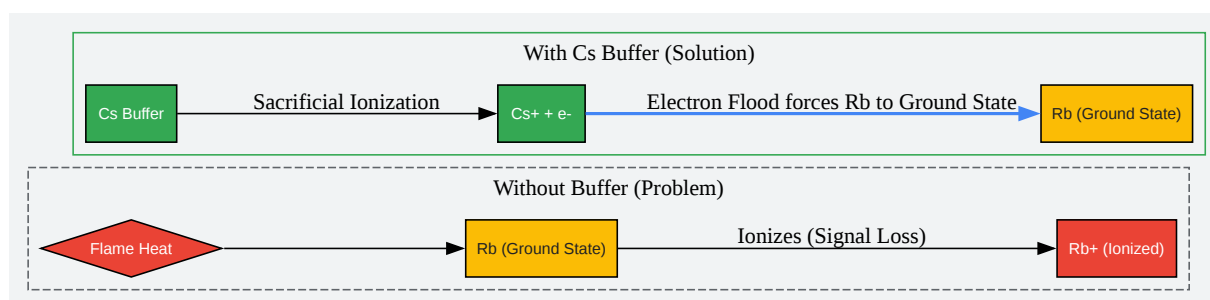

[Click to download full resolution via product page](#)

Caption: The addition of Cesium (green) floods the flame with electrons, reversing the ionization equilibrium and forcing Rubidium back to the measurable ground state (yellow).

Module 2: ICP-MS Determination

Issue: Isobaric Interference (

overlaps

).

The Mechanism: Mass Overlap

Rubidium has two natural isotopes:

(72.17%) and

(27.83%). Strontium-87 (

) has the exact same nominal mass. In biological samples with high Sr/Rb ratios (e.g., bone, urine), this causes false positives for Rb.

Protocol I-1: Isotope Selection & Mass Shift

Decision Matrix:

- Are you quantifying total Rb?

- Action: Measure

- .

- Reason: It is free from Sr interference.

- Caution: Watch for

- or

- if those elements are high, though these are rare.

- Must you measure

- (e.g., for isotope ratios)?

- Action: Use a Collision/Reaction Cell (CRC) with Oxygen (ngcontent-ng-c780544980="" _ngghost-ng-c1768664871="" class="inline ng-star-inserted">

-).

- o Mechanism:^[3]^[4] Sr reacts vigorously with

to form

(+16 amu). Rb is effectively inert to

^[5]

- o Result:

moves to mass 103 (

), leaving

interference-free at mass 87.^[6]

Quantitative Data: Isotope & Interference Table

Isotope	Abundance	Primary Interference	Mitigation Strategy
⁸⁷ Sr	72.17%	Negligible (Clean)	Preferred for Quant. Use He KED mode to remove polyatomics.
⁸⁶ Sr	27.83%	(Isobaric)	Reaction Mode (). Shift Sr to mass 103.
⁸⁴ Sr	7.00%	(Isobaric)	Measure as at m/z 103. ^[6]

Visual Logic: Mass Shift Workflow

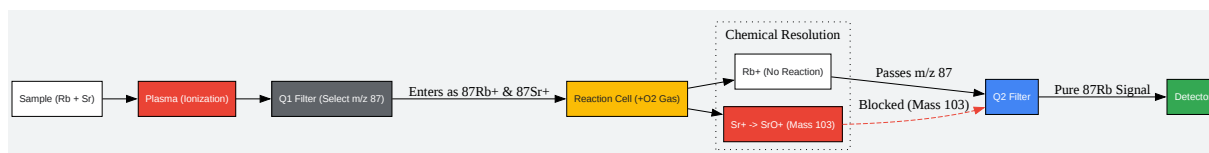

[Click to download full resolution via product page](#)

Caption: Using Oxygen reaction gas, Strontium is mass-shifted to SrO (mass 103), while Rubidium remains at mass 87, allowing for interference-free detection.[7][6]

Module 3: Troubleshooting & FAQs

Q1: My Rb calibration curve flattens at high concentrations in AAS. Why?

A: This is likely Self-Absorption.

- Cause: At high concentrations, ground-state atoms in the cooler outer edges of the flame absorb the light emitted by the hollow cathode lamp before it reaches the detector.
- Fix:
 - Rotate the burner head 90 degrees (reduces path length).
 - Use a secondary wavelength with lower sensitivity (e.g., 420.2 nm or 421.6 nm) to extend the linear range.

Q2: I see significant "memory effects" (carryover) in ICP-MS.

A: Rubidium is "sticky" in glass spray chambers and tubing.

- Fix:

- Wash Solution: Use 2%
 - + 0.5% Triton X-100 (surfactant helps desorb Rb).
- Hardware: Switch to a PFA (fluoropolymer) spray chamber and nebulizer if analyzing trace Rb after high-concentration samples.

Q3: How do I validate my method is free from Matrix Interference?

A: Perform a Spike Recovery Test (Standard Addition).

- Aliquot your sample.
- Spike it with a known concentration of Rb (e.g., 50% of expected value).
- Calculate Recovery:
- Target: 85-115%.
 - If < 85%:[1] You have ion suppression (matrix effect). Dilute the sample or use Method of Standard Additions (MSA).
 - If > 115%: You have ionization enhancement (AAS) or polyatomic interference (ICP). Check your Buffer (AAS) or Reaction Gas (ICP).

References

- Thermo Fisher Scientific. (2020). An ICP-MS Expedition Through the Elements – Part 1: Rubidium & Strontium. (Discusses interference removal using reaction gas).
- Zhu, Y., et al. (2018).[8] Determination of Rubidium by ID-ICP-QMS/QMS with Fluoromethane as the Reaction Cell Gas. Analytical Sciences.[8] (Details reaction cell chemistry for Rb/Sr separation).

- Chemistry LibreTexts. (2022). Interferences in Atomic Absorption Spectroscopy. (Fundamental physics of ionization buffers and Saha equilibrium).
- USGS. (2001). Methods of Analysis by the U.S. Geological Survey National Water Quality Laboratory. (Protocols for alkali metal determination).

Need Custom Synthesis?

BenchChem offers custom synthesis for rare earth carbides and specific isotopic labeling.

Email: info@benchchem.com or [Request Quote Online](#).

Sources

- [1. jocpr.com](http://jocpr.com) [jocpr.com]
- [2. homework.study.com](http://homework.study.com) [homework.study.com]
- [3. demarcheiso17025.com](http://demarcheiso17025.com) [demarcheiso17025.com]
- [4. syntheticdrugs.unodc.org](http://syntheticdrugs.unodc.org) [syntheticdrugs.unodc.org]
- [5. pepolska.pl](http://pepolska.pl) [pepolska.pl]
- [6. documents.thermofisher.com](http://documents.thermofisher.com) [documents.thermofisher.com]
- [7. spectroscopyonline.com](http://spectroscopyonline.com) [spectroscopyonline.com]
- [8. Determination of Rubidium by ID-ICP-QMS/QMS with Fluoromethane as the Reaction Cell Gas to Separate Spectral Interference from Strontium - PubMed](#) [pubmed.ncbi.nlm.nih.gov]
- To cite this document: BenchChem. [Mitigating interference in the analytical determination of rubidium.]. BenchChem, [2026]. [Online PDF]. Available at: [<https://www.benchchem.com/product/b578940/docs#mitigating-interference-in-the-analytical-determination-of-rubidium>]

Disclaimer & Data Validity:

The information provided in this document is for Research Use Only (RUO) and is strictly not intended for diagnostic or therapeutic procedures. While BenchChem strives to provide accurate protocols, we make no warranties, express or implied, regarding the fitness of this product for every specific experimental setup.

Technical Support: The protocols provided are for reference purposes. Unsure if this reagent suits your experiment?

Need Industrial/Bulk Grade? [Request Custom Synthesis Quote](#)

BenchChem

Our mission is to be the trusted global source of essential and advanced chemicals, empowering scientists and researchers to drive progress in science and industry.

Contact

Address: 3281 E Guasti Rd
Ontario, CA 91761, United States
Phone: (601) 213-4426
Email: info@benchchem.com

[Contact our Ph.D. Support Team for a compatibility check](#)