

Application Note: Strategic Functionalization of 5-Methyl-6-(propylamino)nicotinaldehyde

Author: BenchChem Technical Support Team. **Date:** May 2026

Compound of Interest

Compound Name: 5-Methyl-6-(propylamino)nicotinaldehyde

CAS No.: 1355232-54-0

Cat. No.: B578701

[Get Quote](#)

Introduction: The "Privileged" Kinase Scaffold

5-Methyl-6-(propylamino)nicotinaldehyde (CAS: Derivative of 69879-22-7) represents a highly specialized heterocyclic building block. Unlike generic pyridine aldehydes, this scaffold possesses a "push-pull" electronic architecture defined by the electron-donating propylamino group at C6 and the electron-withdrawing formyl group at C3.

This specific substitution pattern is a critical pharmacophore in the synthesis of Tyrosine Kinase Inhibitors (TKIs), particularly for targets like EGFR and HER2. The C3-aldehyde serves as the "anchor" for generating Michael acceptors (vinyl nitriles/acrylamides) required for covalent inhibition, while the C6-amino group modulates solubility and kinase hinge-binding affinity.

This guide details two high-value synthetic workflows:

- Green Knoevenagel Condensation: Generating Michael acceptor "warheads" using aqueous media.

- Reductive Amination: Creating diverse amine libraries for Structure-Activity Relationship (SAR) exploration.

Mechanism & Reactivity Profile

The reactivity of the C3-formyl group is significantly modulated by the C6-amino substituent. Through resonance, the lone pair on the C6-nitrogen donates electron density into the pyridine ring, rendering the C3-carbonyl carbon less electrophilic than in unsubstituted nicotinaldehyde.

Implication for Protocol Design:

- Standard Conditions: Mild bases (e.g., piperidine) may react sluggishly due to reduced electrophilicity.
- Optimized Conditions: The use of Lewis acids or ionic liquid catalysts (e.g., Choline Hydroxide) in aqueous media enhances the polarization of the carbonyl, facilitating nucleophilic attack while adhering to Green Chemistry principles.

Reaction Pathway Diagram

The following diagram illustrates the divergent pathways for this scaffold:

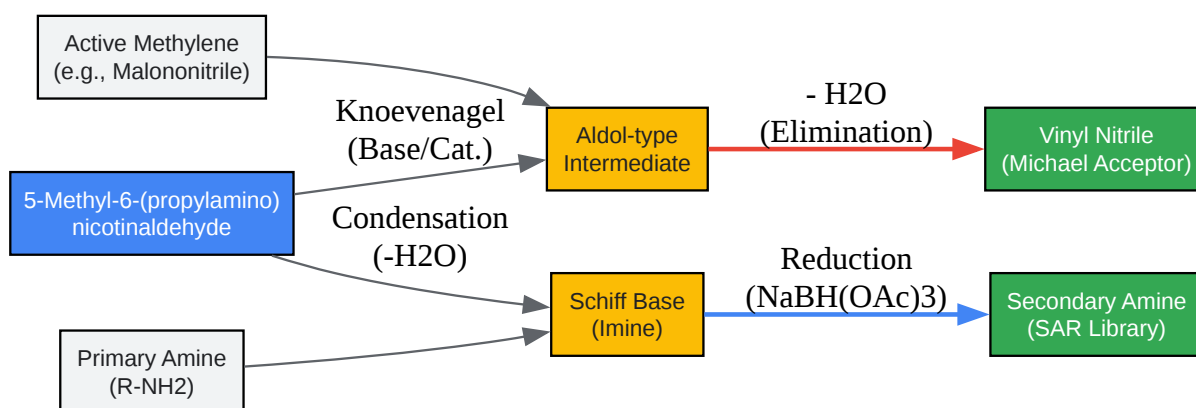

[Click to download full resolution via product page](#)

Caption: Divergent synthetic pathways: Knoevenagel condensation (top) yields covalent warheads; Reductive amination (bottom) yields SAR library candidates.

Protocol A: Green Knoevenagel Condensation (Aqueous Media)

Objective: Synthesis of 2-((5-methyl-6-(propylamino)pyridin-3-yl)methylene)malononitrile.

Application: Creation of covalent kinase inhibitor precursors. Rationale: Traditional methods use benzene/toluene with Dean-Stark traps. This protocol utilizes water and a bio-compatible ionic liquid catalyst, enhancing rate and yield via the "hydrophobic effect," where organic reactants aggregate in water, accelerating the reaction [1, 3].

Materials Table

Reagent	Equiv.	Role	Notes
Scaffold Aldehyde	1.0	Substrate	Purity >95% recommended
Malononitrile	1.1	Nucleophile	CAUTION: Toxic
Choline Hydroxide (ChOH)	5 mol%	Catalyst	46 wt% in water; Green catalyst
Water (Deionized)	10 vol	Solvent	Promotes hydrophobic aggregation
Ethanol	N/A	Recrystallization	For purification

Step-by-Step Procedure

- Setup: In a 25 mL round-bottom flask, suspend **5-Methyl-6-(propylamino)nicotinaldehyde** (1.0 mmol) and Malononitrile (1.1 mmol) in deionized water (3 mL).
- Catalysis: Add Choline Hydroxide (5 mol%) to the heterogeneous mixture.
- Reaction: Stir vigorously at 50°C for 2–4 hours.
 - Observation: The mixture will transition from a suspension to a gummy solid as the hydrophobic product precipitates.

- Monitoring: Check TLC (Mobile phase: 30% EtOAc in Hexanes). The aldehyde spot ($R_f \sim 0.4$) should disappear; a bright fluorescent product spot ($R_f \sim 0.6$) will appear.
- Workup: Cool the mixture to room temperature. Filter the precipitated solid using a sintered glass funnel.
- Wash: Wash the filter cake with cold water (2 x 5 mL) to remove the catalyst and unreacted malononitrile.
- Purification: Recrystallize the crude solid from hot Ethanol.
 - Expected Yield: 85–95%.^[1]
 - Characterization: ^1H NMR will show a distinct singlet for the vinyl proton at δ 7.5–8.0 ppm.

Protocol B: Reductive Amination for SAR Library Generation

Objective: Synthesis of N-benzyl-N-((5-methyl-6-(propylamino)pyridin-3-yl)methyl)amine derivatives. Application: Exploring the "solvent front" region of the kinase binding pocket.

Rationale: Sodium Triacetoxyborohydride (STAB) is used as a mild, selective reducing agent that will not reduce the pyridine ring or the nitro/cyano groups if present elsewhere [2].

Experimental Workflow Diagram

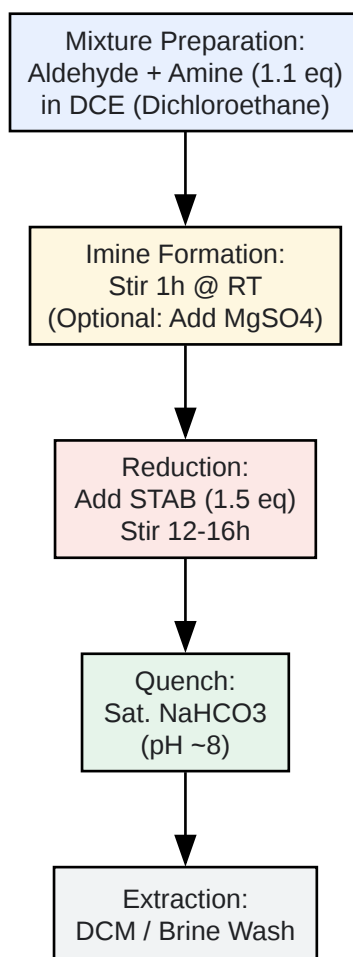

[Click to download full resolution via product page](#)

Caption: One-pot reductive amination workflow using Sodium Triacetoxyborohydride (STAB).

Step-by-Step Procedure

- Imine Formation: Dissolve the aldehyde (0.5 mmol) and the desired amine (0.55 mmol, 1.1 equiv) in 1,2-Dichloroethane (DCE, 5 mL).
 - Note: If using an amine hydrochloride salt, add 1.1 equiv of TEA (Triethylamine) to liberate the free base.
 - Tip: Add activated 4Å molecular sieves if the reaction is sluggish.
- Equilibration: Stir at Room Temperature (RT) for 60 minutes to allow imine formation.
- Reduction: Add Sodium Triacetoxyborohydride (STAB) (1.5 equiv) in one portion.

- Caution: Mild gas evolution (H₂) may occur.
- Completion: Stir overnight (12–16 hours) under Nitrogen.
- Quench: Add saturated aqueous NaHCO₃ (5 mL) and stir for 15 minutes to quench excess borohydride.
- Extraction: Extract with Dichloromethane (DCM) (3 x 10 mL). Dry combined organics over Na₂SO₄.
- Purification: Flash column chromatography (DCM:MeOH 95:5).

Troubleshooting & Optimization

Issue	Probable Cause	Solution
Low Yield (Knoevenagel)	Aldehyde deactivation by C6-amine.	Switch solvent to Ethanol and use Piperidine/Acetic Acid (cat.) under reflux. The heat overcomes the electronic deactivation.
No Reaction (Reductive Amination)	Steric hindrance at C5-Methyl.	Use a stronger Lewis acid catalyst like Ti(OiPr) ₄ (1.2 equiv) to pre-form the imine before adding the reducing agent.
Product Degradation	Oxidation of the amine.	Perform all reactions under an inert atmosphere (N ₂ or Ar). Store final products at -20°C.

References

- RSC Green Chemistry: A mild synthesis of substituted 1,8-naphthyridines using water as the reaction solvent. (Demonstrates aqueous condensation viability for aminonicotinaldehydes).
- BenchChem Application Note: Application Notes and Protocols for 6-(Methyl(phenyl)amino)nicotinaldehyde. (General reactivity profiles for 6-amino-

nicotinaldehydes).

- ACS Omega:Gram-Scale Synthesis of 1,8-Naphthyridines in Water: The Friedlander Reaction Revisited.
- Semantic Scholar:Recent Developments in Knoevenagel Condensation Reaction. (Review of catalytic systems including ionic liquids).

Need Custom Synthesis?

BenchChem offers custom synthesis for rare earth carbides and specific isotopiclabeling.

Email: info@benchchem.com or [Request Quote Online](#).

Sources

- [1. researchgate.net \[researchgate.net\]](https://www.researchgate.net)
- To cite this document: BenchChem. [Application Note: Strategic Functionalization of 5-Methyl-6-(propylamino)nicotinaldehyde]. BenchChem, [2026]. [Online PDF]. Available at: [<https://www.benchchem.com/product/b578701/docs#application-note-strategic-functionalization-of-5-methyl-6-propylamino-nicotinaldehyde>]

Disclaimer & Data Validity:

The information provided in this document is for Research Use Only (RUO) and is strictly not intended for diagnostic or therapeutic procedures. While BenchChem strives to provide accurate protocols, we make no warranties, express or implied, regarding the fitness of this product for every specific experimental setup.

Technical Support: The protocols provided are for reference purposes. Unsure if this reagent suits your experiment?

Need Industrial/Bulk Grade? [Request Custom Synthesis Quote](#)

BenchChem

Our mission is to be the trusted global source of essential and advanced chemicals, empowering scientists and researchers to drive progress in science and industry.

Contact

Address: 3281 E Guasti Rd
Ontario, CA 91761, United States
Phone: (601) 213-4426
Email: info@benchchem.com

[Contact our Ph.D. Support Team for a compatibility check](#)