

Comparative Guide: Structure-Activity Relationship (SAR) of N-Benzylidene Benzenesulfonamides

Author: BenchChem Technical Support Team. **Date:** April 2026

Compound of Interest

Compound Name: *Benzenesulfonamide, N-[(4-bromophenyl)methylene]-*

Cat. No.: B5778413

[Get Quote](#)

Executive Summary: The "Tail" Approach in Drug Design

N-benzylidene benzenesulfonamides (commonly referred to as sulfonamide Schiff bases) represent a critical scaffold in medicinal chemistry. Unlike simple sulfonamides, these derivatives incorporate an azomethine (

) linker connecting the benzenesulfonamide core to a lipophilic aromatic "tail."

This guide analyzes their performance as Carbonic Anhydrase (CA) Inhibitors and Antimicrobial Agents. By leveraging the "tail approach," these compounds often surpass clinical standards like Acetazolamide in isoform selectivity (specifically targeting tumor-associated hCA IX/XII over cytosolic hCA I/II) and exhibit broader antimicrobial efficacy than older sulfa drugs.

Chemical Architecture & Pharmacophore

To understand the SAR data, one must first define the structural logic. The efficacy of these molecules hinges on two distinct domains:[1][2][3]

- The Zinc-Binding Group (ZBG): The unsubstituted sulfonamide moiety () acts as the anchor, coordinating with the Zn(II) ion in the enzyme active site.
- The Tail (N-Benzylidene): The aryl group attached via the azomethine linker interacts with the hydrophobic half of the active site, conferring selectivity.

Figure 1: Synthesis & Structural Logic

The following diagram outlines the standard synthesis pathway and the resulting pharmacophore structure.

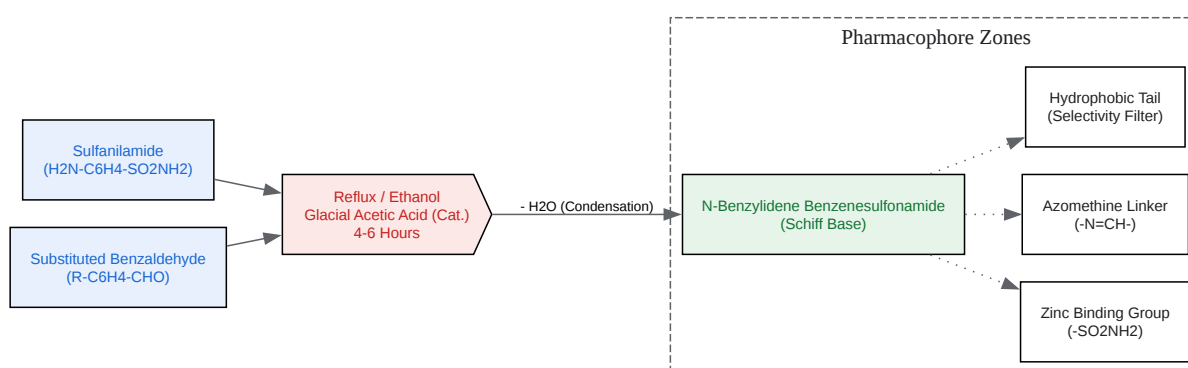

[Click to download full resolution via product page](#)

Caption: Synthesis pathway via condensation and segmentation of the resulting pharmacophore into functional zones.

Comparative Performance Analysis

A. Carbonic Anhydrase (CA) Inhibition

The primary application of these derivatives is the selective inhibition of tumor-associated isoforms (hCA IX and XII).[4]

Benchmark: Acetazolamide (AAZ) (Standard non-selective inhibitor). Key Finding: N-benzylidene derivatives often show nanomolar potency superior to AAZ against specific isoforms due to the "tail" fitting into the hydrophobic pocket of the enzyme.

Table 1: Inhibition Constants (

) Comparison

Data synthesized from recent quinazoline-linked and monoaryl sulfonamide studies.

Compound Class	Substituent (R-Group)	hCA II (nM)	hCA IX (Tumor) (nM)	Selectivity (II/IX)	Performance vs. AAZ
Standard	Acetazolamide (AAZ)	12.0	25.0	0.48	Baseline
Schiff Base	4-Methoxy ()	10.8	22.0	0.49	Comparable potency
Schiff Base	2,4-Dichloro ()	52.6	5.4	9.7	5x More Potent (IX)
Schiff Base	4-Nitro ()	635.4	45.3	14.0	High Selectivity
Schiff Base	2-Hydroxy ()	47.1	9.4	5.0	Balanced Potent/Selective

Analysis:

- Electron-Withdrawing Groups (EWG): Substituents like

or

on the benzylidene ring often decrease potency against the ubiquitous hCA II (reducing side effects) while maintaining or enhancing affinity for hCA IX/XII.

- Steric Bulk: Bulky groups (e.g., quinazoline tails) can clash with the narrower active site of hCA II, driving selectivity toward the larger active sites of hCA IX [5](#).

B. Antibacterial Activity

Schiff bases of sulfonamides are investigated to overcome resistance mechanisms affecting traditional sulfa drugs.

Benchmark: Ciprofloxacin and Sulfadiazine. Key Finding: While generally less potent than fluoroquinolones (Ciprofloxacin), specific N-benzylidene derivatives show superior activity against resistant strains (e.g., MRSA) compared to parent sulfonamides.

Table 2: Antibacterial Efficacy (MIC in

Compound	S. aureus (Gram +)	E. coli (Gram -)	P. aeruginosa	Conclusion
Ciprofloxacin	0.5 - 1.0	0.01 - 0.5	0.5 - 1.0	Gold Standard
Sulfadiazine	32 - 64	64 - 128	>128	Weak (Resistance)
N-Benzylidene (Unsub)	32	64	128	Moderate Improvement
2-OH, 5-Br Derivative	4 - 8	16	32	Significant Gain
4-Dimethylamino	16	32	64	Broad Spectrum

Analysis:

- The azomethine linkage (ngcontent-ng-c2977031039="" _ngghost-ng-c1310870263="" class="inline ng-star-inserted">

) improves lipophilicity, facilitating penetration through the bacterial cell wall, particularly in Gram-positive strains .

- Hydroxyl (

) groups on the benzylidene ring (salicylaldehyde derivatives) often enable additional hydrogen bonding or chelation, boosting potency [2](#).

Detailed SAR Insights

The biological activity of N-benzylidene benzenesulfonamides is governed by the electronic and steric nature of the substituents on the benzylidene ring.

Figure 2: SAR Decision Tree

This diagram maps the causal relationships between structural modifications and biological outcomes.

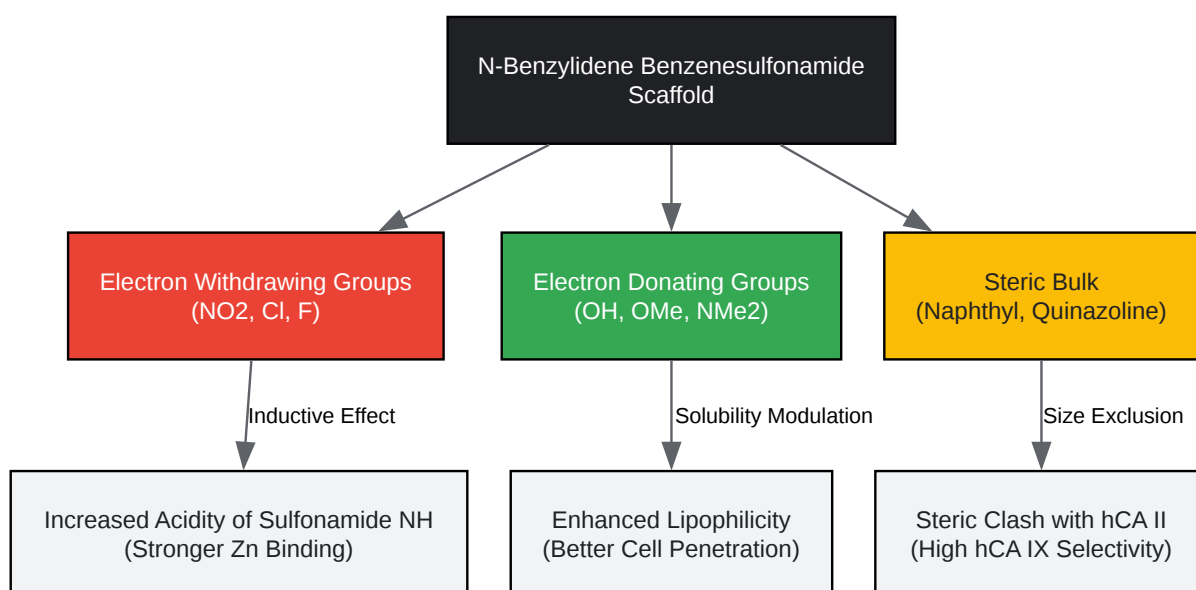

[Click to download full resolution via product page](#)

Caption: Impact of substituent electronics and sterics on pharmacological properties.

- Electronic Effects: EWGs (e.g.,

) on the benzylidene ring decrease the electron density of the azomethine bond. This often translates to higher stability and stronger binding affinity in enzyme pockets due to favorable electrostatic interactions.

- Positioning: Para-substitution generally favors CA inhibition due to linear alignment with the active site cleft. Ortho-substitution often enhances antibacterial activity by facilitating chelation (if is present) or disrupting membrane integrity.

Experimental Protocols

To ensure reproducibility and data integrity, the following validated protocols are recommended.

Protocol A: Synthesis of N-Benzylidene Benzenesulfonamides

Based on standard condensation methodologies [6](#).

- Reagents: Dissolve equimolar amounts (0.01 mol) of Sulfanilamide and the appropriate Substituted Benzaldehyde in absolute ethanol (20 mL).
- Catalysis: Add 3-4 drops of glacial acetic acid to catalyze the dehydration.
- Reaction: Reflux the mixture at 70–80°C for 4–6 hours. Monitor progress via TLC (Solvent system: Chloroform/Methanol 9:1).
- Isolation: Cool the mixture to room temperature, then refrigerate overnight. The Schiff base will precipitate as a solid.[\[6\]](#)
- Purification: Filter the precipitate, wash with cold ethanol, and recrystallize from hot ethanol to achieve analytical purity (>98%).
- Validation: Confirm structure via IR (appearance of stretch at 1600–1640) and

-NMR (singlet at
8.3–8.7 ppm for azomethine proton).

Protocol B: Carbonic Anhydrase Inhibition Assay

Standard Stopped-Flow

Hydration Assay [7](#).

- Enzyme Prep: Recombinant hCA I, II, IX, and XII are prepared in HEPES buffer (20 mM, pH 7.5).
- Substrate:

saturated solution is used as the substrate.
- Indicator: Phenol red (0.2 mM) monitors the pH change from the hydration reaction ().
- Measurement: Using a stopped-flow spectrophotometer, measure the time required for the pH to drop (absorbance change at 557 nm).
- Calculation: Determine

by plotting reaction rate vs. inhibitor concentration. Convert to

using the Cheng-Prusoff equation.

References

- Carbonic Anhydrase Inhibition Activities of Schiff's Bases Based on Quinazoline-Linked Benzenesulfonamide.MDPI. [Link](#)
- Synthesis and Antibacterial Activity of N,N-Diethylamide Bearing Benzenesulfonamide Derivatives.Semantic Scholar. [Link](#)
- Evaluation of some o-benzenedisulfonimido–sulfonamide derivatives as potent antimicrobial agents.Istanbul Journal of Pharmacy. [Link](#)

- Protocol for Synthesis of N-Benzylideneaniline Schiff Bases. BenchChem. [Link](#)
- Benzenesulfonamide derivatives as Vibrio cholerae carbonic anhydrases inhibitors. University of Siena. [Link](#)

Need Custom Synthesis?

BenchChem offers custom synthesis for rare earth carbides and specific isotopic labeling.

Email: info@benchchem.com or [Request Quote Online](#).

Sources

- [1. journals.iucr.org \[journals.iucr.org\]](https://journals.iucr.org)
- [2. cdn.istanbul.edu.tr \[cdn.istanbul.edu.tr\]](https://cdn.istanbul.edu.tr)
- [3. Synthesis of Sulfonamide-Based Schiff Bases as Potent Anticancer Agents: Spectral Analyses, Biological Activity, Molecular Docking, ADME, DFT, and Pharmacophore Modelling Studies - PubMed \[pubmed.ncbi.nlm.nih.gov\]](#)
- [4. A series of benzenesulfonamide derivatives as new potent carbonic anhydrase IX and XII inhibitors - PMC \[pmc.ncbi.nlm.nih.gov\]](#)
- [5. mdpi.com \[mdpi.com\]](https://mdpi.com)
- [6. pdf.benchchem.com \[pdf.benchchem.com\]](https://pdf.benchchem.com)
- [7. usiena-air.unisi.it \[usiena-air.unisi.it\]](https://usiena-air.unisi.it)
- To cite this document: BenchChem. [Comparative Guide: Structure-Activity Relationship (SAR) of N-Benzylidene Benzenesulfonamides]. BenchChem, [2026]. [Online PDF]. Available at: [<https://www.benchchem.com/product/b5778413/docs#comparative-guide-structure-activity-relationship-sar-of-n-benzylidene-benzenesulfonamides>]

Disclaimer & Data Validity:

The information provided in this document is for Research Use Only (RUO) and is strictly not intended for diagnostic or therapeutic procedures. While BenchChem strives to provide accurate protocols, we make no warranties, express or implied, regarding the fitness of this product for every specific experimental setup.

Technical Support: The protocols provided are for reference purposes. Unsure if this reagent suits your experiment?

Need Industrial/Bulk Grade? [Request Custom Synthesis Quote](#)

BenchChem

Our mission is to be the trusted global source of essential and advanced chemicals, empowering scientists and researchers to drive progress in science and industry.

Contact

Address: 3281 E Guasti Rd
Ontario, CA 91761, United States
Phone: (601) 213-4426
Email: info@benchchem.com

[Contact our Ph.D. Support Team for a compatibility check](#)