

Application Notes: Modifying Amine-Coated Surfaces with m-PEG12-NHS Ester

Author: BenchChem Technical Support Team. **Date:** April 2026

Compound of Interest

Compound Name: *m*-PEG12-NHS ester

CAS No.: 174569-25-6

Cat. No.: B575342

[Get Quote](#)

For Researchers, Scientists, and Drug Development Professionals

Introduction

The modification of amine-coated surfaces with methoxy-polyethylene glycol-N-hydroxysuccinimidyl ester (**m-PEG12-NHS ester**) is a widely adopted strategy in biomedical research and drug development to impart desirable physicochemical properties to materials.[1] This process, known as PEGylation, involves the covalent attachment of a hydrophilic 12-unit polyethylene glycol (PEG) spacer to a surface functionalized with primary amine groups (-NH₂).[1][2] The **m-PEG12-NHS ester** is a heterobifunctional linker composed of a methoxy-terminated PEG chain, which prevents unwanted crosslinking, and an N-hydroxysuccinimidyl (NHS) ester reactive group that specifically targets primary amines.[3] The reaction between the NHS ester and an amine forms a stable, irreversible amide bond.[3]

The primary advantages of modifying surfaces with **m-PEG12-NHS ester** include a significant reduction in non-specific protein adsorption, enhanced biocompatibility, and improved solubility of conjugated molecules.[2] These characteristics are critical for a variety of applications, including the development of medical devices, drug delivery systems, diagnostic assays, and

antibody-drug conjugates (ADCs).[3] The 12-unit PEG linker provides a balance of hydrophilicity and spacer length, which can enhance the solubility and stability of the conjugated biomolecule while minimizing steric hindrance.[3]

Principle of Reaction

The surface modification process is based on the nucleophilic acyl substitution reaction between the primary amine groups on the surface and the NHS ester of the **m-PEG12-NHS ester**.[3] The deprotonated primary amine acts as a nucleophile, attacking the carbonyl carbon of the NHS ester. This forms a transient tetrahedral intermediate that subsequently collapses, releasing the N-hydroxysuccinimide (NHS) leaving group and forming a stable amide bond.[3] This reaction is most efficient at a slightly basic pH (7.2-8.5), which ensures that the primary amines are in their nucleophilic, deprotonated state.[4] However, a competing hydrolysis reaction of the NHS ester can occur in aqueous solutions, which is also pH-dependent and can reduce the efficiency of the conjugation.[2] Therefore, careful control of reaction conditions such as pH, temperature, and reagent concentration is crucial for successful surface modification.[2]

Key Applications

- **Reducing Non-Specific Protein Adsorption:** The hydrophilic and flexible PEG layer creates a steric barrier that effectively prevents the non-specific adsorption of proteins to the surface. [4] This is particularly important for medical implants, biosensors, and nanoparticles to minimize biofouling and maintain their intended function in biological environments.[4][5]
- **Improving Biocompatibility:** PEGylated surfaces are generally well-tolerated by the body, reducing the immunogenicity of the material.[4] The PEG layer can shield antigenic sites on the surface, preventing recognition by the immune system.[4]
- **Drug Delivery Systems:** Modifying the surface of nanoparticles and liposomes with **m-PEG12-NHS ester** can prolong their circulation half-life in the bloodstream.[4] The increased hydrodynamic volume of the PEGylated particles reduces their renal clearance and uptake by the reticuloendothelial system.[4]
- **Bioconjugation and Diagnostics:** The **m-PEG12-NHS ester** can be used to immobilize proteins, antibodies, or other biomolecules onto a surface for the development of diagnostic

assays, such as ELISA and microarrays.[3] The PEG spacer helps to maintain the biological activity of the immobilized molecule by providing a flexible linker and minimizing steric hindrance.[3]

Quantitative Data Summaries

The following tables summarize key quantitative data related to the modification of amine-coated surfaces with PEG linkers and the resulting effects on surface properties.

Table 1: Reaction Conditions for Surface Modification with m-PEG-NHS Esters

Parameter	Recommended Range	Notes
m-PEG12-NHS Ester Concentration	1 - 10 mg/mL	The optimal concentration depends on the desired grafting density and the density of amine groups on the surface.[2]
Reaction Buffer	Phosphate-buffered saline (PBS), HEPES, or borate buffer	Avoid buffers containing primary amines, such as Tris or glycine, as they will compete with the surface amines for reaction with the NHS ester.[5]
Reaction pH	7.2 - 8.5	A compromise between maximizing the nucleophilicity of the primary amines and minimizing the hydrolysis of the NHS ester.[4]
Reaction Temperature	Room temperature (20-25°C) or 4°C	Lower temperatures can be used to slow down the hydrolysis of the NHS ester, especially for longer reaction times.[2]
Reaction Time	30 - 120 minutes	The optimal reaction time should be determined empirically.[2]
Quenching Buffer	25 - 50 mM Tris or glycine buffer	Used to stop the reaction by consuming any unreacted NHS esters.[2]

Table 2: Characterization of Surfaces Before and After PEGylation

Analysis Technique	Parameter	Before Modification (Amine Surface)	After m-PEG12-NHS Ester Modification
X-ray Photoelectron Spectroscopy (XPS)	C1s Peak (C-O component)	Low intensity	Significant increase, characteristic peak around 286.5 eV[6]
	N1s Peak	Present	May decrease in intensity due to shielding by the PEG layer.
Water Contact Angle (WCA)	Static Contact Angle	Typically 40-60°	Decreased to <30°, indicating increased hydrophilicity.[2]
Atomic Force Microscopy (AFM)	Surface Roughness (RMS)	Varies with substrate	Generally results in a smoother, more uniform surface.

Table 3: Representative Data on Protein Adsorption to PEGylated Surfaces

This table presents representative data from studies investigating the effect of PEG surface density on the adsorption of various proteins. While not specific to **m-PEG12-NHS ester**, it illustrates the general trend of reduced protein adsorption with increasing PEG density.

PEG Surface Density (chains/nm ²)	Adsorbed Fibronectin (ng/cm ²) ¹	Adsorbed Myoglobin (ng/cm ²) ²	Adsorbed Albumin (ng/cm ²) ²	Adsorbed Fibrinogen (ng/cm ²) ²
0 (Bare Surface)	~350	~200	~150	~400
Low Density (~0.05)	~150	~100	~80	~200
Medium Density (~0.12)	~50	~50	~40	~100
High Density (~0.29)	~75	~25	~20	~50

¹Data adapted from a study using 5kDa PEG.[1] ²Data adapted from a study using PLL-g-PEG. [4][5]

Experimental Protocols

Protocol 1: Modification of a Planar Amine-Coated Surface (e.g., Glass Slide)

Materials:

- Amine-functionalized glass slide
- **m-PEG12-NHS ester**
- Anhydrous dimethyl sulfoxide (DMSO) or dimethylformamide (DMF)
- Reaction Buffer: 0.1 M Phosphate-buffered saline (PBS), pH 7.2
- Quenching Buffer: 50 mM Tris-HCl, pH 8.0
- Deionized (DI) water
- Nitrogen gas

Procedure:

- Surface Preparation:
 - Clean the amine-functionalized glass slide by sonicating in DI water and then ethanol for 15 minutes each.
 - Dry the slide under a gentle stream of nitrogen gas.
 - Place the clean, dry slide in a suitable reaction vessel.
- Preparation of **m-PEG12-NHS Ester** Solution:
 - Allow the vial of **m-PEG12-NHS ester** to equilibrate to room temperature before opening to prevent moisture condensation.
 - Immediately before use, dissolve the required amount of **m-PEG12-NHS ester** in anhydrous DMSO or DMF to create a 10 mg/mL stock solution.
- PEGylation Reaction:
 - Add the Reaction Buffer (PBS, pH 7.2) to the reaction vessel to completely cover the glass slide.
 - Add the freshly prepared **m-PEG12-NHS ester** stock solution to the buffer to achieve a final concentration of 1-10 mg/mL. The volume of the organic solvent should not exceed 10% of the total reaction volume.
 - Incubate the reaction for 30-60 minutes at room temperature with gentle agitation.
- Quenching the Reaction:
 - Add the Quenching Buffer to the reaction vessel to a final concentration of 50 mM.
 - Incubate for an additional 15-30 minutes at room temperature to ensure all unreacted NHS esters are hydrolyzed or capped.
- Washing:

- Remove the reaction mixture from the vessel.
- Wash the surface thoroughly three times with the Reaction Buffer (PBS).
- Rinse the surface three times with DI water to remove salts.
- Drying and Storage:
 - Dry the modified surface under a gentle stream of nitrogen gas.
 - Store the PEGylated surface in a clean, dry, and sealed container at 4°C until further use.

Protocol 2: Characterization of the PEGylated Surface

A. Water Contact Angle Measurement:

- Place a 5-10 μL droplet of DI water onto the surface of the unmodified and the PEGylated glass slides.
- Immediately capture an image of the droplet.
- Measure the angle between the substrate surface and the tangent of the droplet at the three-phase contact line.
- A significant decrease in the contact angle for the PEGylated surface compared to the unmodified surface indicates successful modification and increased hydrophilicity.[2]

B. X-ray Photoelectron Spectroscopy (XPS):

- Acquire a survey spectrum of the PEGylated surface to determine the elemental composition.
- Acquire a high-resolution C1s spectrum.
- Deconvolute the C1s spectrum to identify the different carbon species. A prominent peak at a binding energy of approximately 286.5 eV corresponds to the C-O bonds of the PEG backbone, confirming the presence of the PEG layer.[6]

Mandatory Visualizations

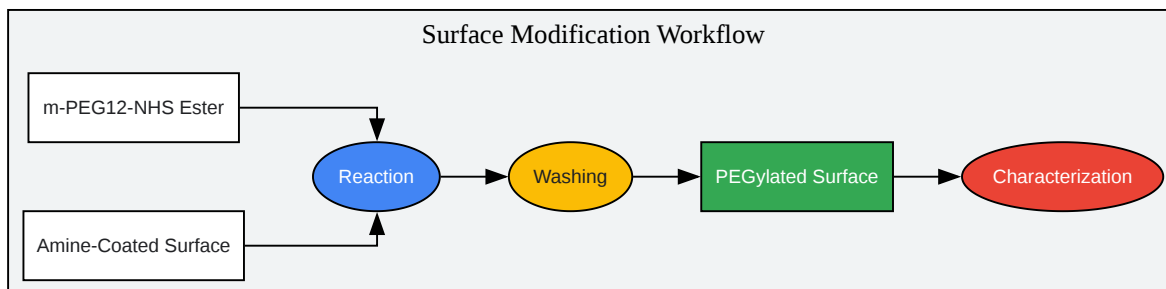

[Click to download full resolution via product page](#)

Caption: Experimental workflow for modifying and characterizing amine-coated surfaces.

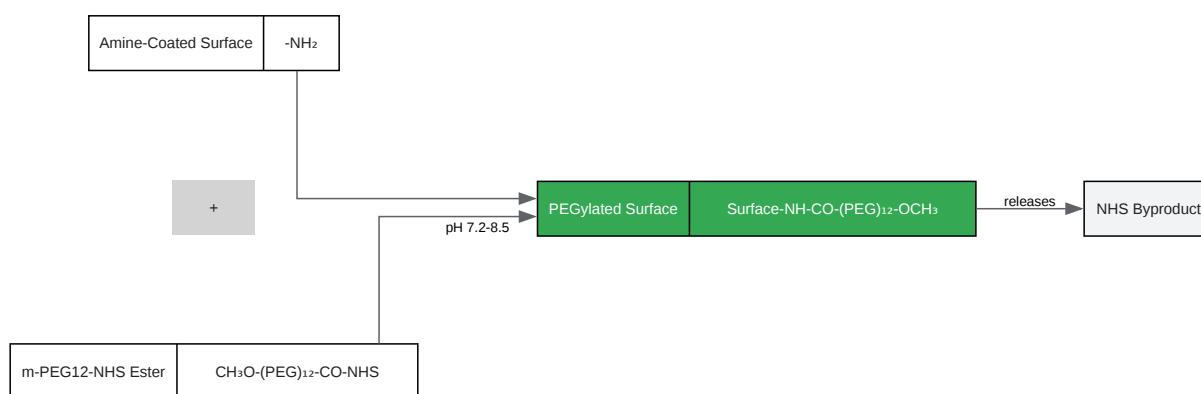

[Click to download full resolution via product page](#)

Caption: Reaction scheme of **m-PEG12-NHS ester** with an amine-coated surface.

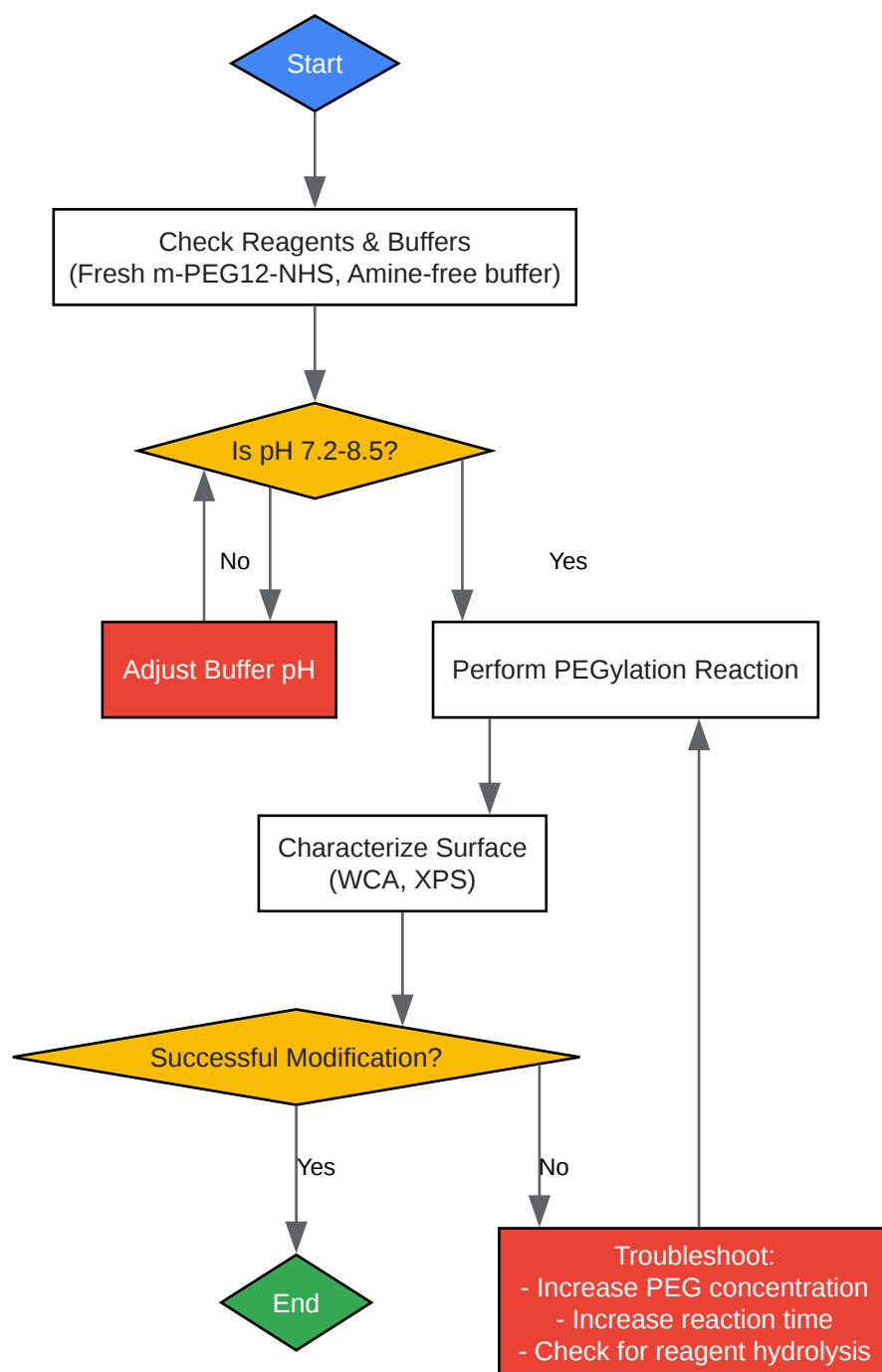

[Click to download full resolution via product page](#)

Caption: Logical workflow for the PEGylation process and troubleshooting.

Need Custom Synthesis?

BenchChem offers custom synthesis for rare earth carbides and specific isotopic labeling.

Email: info@benchchem.com or [Request Quote Online](#).

References

- [1. A correlation study of protein adsorption and cell behaviors on substrates with different densities of PEG chains - PubMed \[pubmed.ncbi.nlm.nih.gov\]](#)
- [2. benchchem.com \[benchchem.com\]](#)
- [3. benchchem.com \[benchchem.com\]](#)
- [4. The Influence of PEG Architecture on Protein Adsorption and Conformation - PMC \[pmc.ncbi.nlm.nih.gov\]](#)
- [5. researchgate.net \[researchgate.net\]](#)
- [6. researchgate.net \[researchgate.net\]](#)
- To cite this document: BenchChem. [Application Notes: Modifying Amine-Coated Surfaces with m-PEG12-NHS Ester]. BenchChem, [2026]. [Online PDF]. Available at: [\[https://www.benchchem.com/product/b575342/docs#application-notes-modifying-amine-coated-surfaces-with-m-peg12-nhs-ester\]](https://www.benchchem.com/product/b575342/docs#application-notes-modifying-amine-coated-surfaces-with-m-peg12-nhs-ester)

Disclaimer & Data Validity:

The information provided in this document is for Research Use Only (RUO) and is strictly not intended for diagnostic or therapeutic procedures. While BenchChem strives to provide accurate protocols, we make no warranties, express or implied, regarding the fitness of this product for every specific experimental setup.

Technical Support: The protocols provided are for reference purposes. Unsure if this reagent suits your experiment?

Need Industrial/Bulk Grade? [Request Custom Synthesis Quote](#)

BenchChem

Our mission is to be the trusted global source of essential and advanced chemicals, empowering scientists and researchers to drive progress in science and industry.

Contact

Address: 3281 E Guasti Rd

Ontario, CA 91761, United States

Phone: (601) 213-4426

Email: info@benchchem.com

Contact our Ph.D. Support Team for a compatibility check