

# Technical Support Center: Optimizing Trifluoromethyl Pyrazole Synthesis

**Author:** BenchChem Technical Support Team. **Date:** May 2026

## Compound of Interest

Compound Name: 2,2,2-trifluoro-1-(1H-pyrazol-4-yl)ethanone  
CAS No.: 161957-47-7  
Cat. No.: B574069

[Get Quote](#)

Welcome to the technical support center for trifluoromethyl pyrazole synthesis. This guide is designed for researchers, scientists, and drug development professionals to troubleshoot common issues and optimize reaction conditions. Trifluoromethylated pyrazoles are crucial scaffolds in pharmaceuticals and agrochemicals, but their synthesis can present unique challenges, including low yields and poor regioselectivity.[1][2][3][4]

## Frequently Asked Questions (FAQs) & Troubleshooting

### Q1: My reaction yield is critically low. What are the common causes and how can I improve it?

Low yields in pyrazole synthesis, particularly the Knorr synthesis involving 1,3-dicarbonyl compounds and hydrazines, can arise from several factors.[5] Often, the issue is related to starting material purity, suboptimal reaction conditions, or the formation of stable intermediates that do not convert to the final product.[6]

### Troubleshooting Steps:

- **Assess Starting Material Purity:** Ensure the trifluoromethyl-1,3-dicarbonyl compound and the hydrazine derivative are pure. Hydrazine reagents can degrade, so using a fresh batch is recommended.<sup>[5]</sup> Impurities can lead to side reactions that reduce yield.<sup>[5]</sup>
- **Optimize Stoichiometry:** A slight excess (1.0-1.2 equivalents) of the hydrazine reagent can help drive the reaction to completion.<sup>[5]</sup>
- **Monitor the Reaction:** Use Thin Layer Chromatography (TLC) or Liquid Chromatography-Mass Spectrometry (LC-MS) to track the reaction's progress and determine the optimal time for completion, preventing the formation of degradation products.<sup>[5]</sup>
- **Adjust Temperature:** While some reactions proceed at room temperature, others require heating to facilitate the dehydration of intermediates.<sup>[6][7]</sup> For instance, in the synthesis of 3-(perfluoroalkylated)-1H-pyrazoles, increasing the temperature to 100 °C significantly improves yields.<sup>[8]</sup>
- **Consider Solvent Choice:** The solvent can play a critical role. While ethanol is common, dipolar aprotic solvents or fluorinated alcohols may offer better results depending on the specific substrates.<sup>[7][9][10]</sup>

## Q2: I'm observing a mixture of two regioisomers. How can I improve regioselectivity?

The formation of regioisomeric mixtures is a significant challenge when using unsymmetrical trifluoromethyl-1,3-dicarbonyls.<sup>[5]</sup> The nucleophilic attack from the hydrazine can occur at either of the two carbonyl carbons, leading to different pyrazole products.<sup>[5]</sup> The outcome is governed by the electronic and steric properties of the substituents on both reactants.<sup>[5]</sup>

### Strategies to Control Regioselectivity:

- **Solvent Engineering:** The choice of solvent can dramatically influence the isomeric ratio.<sup>[9]</sup> Using fluorinated alcohols like 2,2,2-trifluoroethanol (TFE) or 1,1,1,3,3,3-hexafluoro-2-propanol (HFIP) has been shown to significantly increase regioselectivity in favor of the 3-trifluoromethyl derivative.<sup>[9]</sup>

- Nature of the Hydrazine: Using arylhydrazine hydrochlorides versus the corresponding free hydrazine can lead exclusively to different regioisomers.[11][12] Acidic conditions can alter the reaction pathway compared to neutral or basic conditions.[5][6]
- Substituent Effects: The electronic nature of substituents on the hydrazine can guide selectivity. For instance, modifying a carbonyl group on the pyrazole to a hydrazone has been used to control the N-alkylation selectivity of trifluoromethylated pyrazoles.[13]

#### Data Presentation: Effect of Solvent on Regioselectivity

The following table summarizes the effect of different solvents on the product ratio in the reaction of a trifluoromethyl- $\beta$ -diketone with methylhydrazine.

Entry	Solvent	Product Ratio (3-CF <sub>3</sub> : 5-CF <sub>3</sub> Isomer)	Reference
1	Ethanol (EtOH)	Low selectivity, major product is often the 5-CF <sub>3</sub> isomer	
2	2,2,2-Trifluoroethanol (TFE)	85 : 15	
3	1,1,1,3,3,3-Hexafluoro-2-propanol (HFIP)	97 : 3	

This data clearly indicates that fluorinated alcohols can be highly effective in directing the synthesis towards the desired 3-trifluoromethyl pyrazole isomer.

### Q3: I'm struggling with the purification of my final compound. What are the best practices?

Fluorinated compounds often exhibit unique properties that can complicate standard purification methods.[14] Their altered polarity and potential for unique intermolecular interactions require specialized techniques.

Recommended Purification Techniques:

- High-Performance Liquid Chromatography (HPLC): Reverse-phase HPLC (RP-HPLC) is a very effective tool for purifying fluorinated compounds.[14] Careful selection of the stationary and mobile phases is crucial for achieving good separation.
- Column Chromatography: Standard column chromatography on silica gel is frequently used. Gradient elution, for example with ethyl acetate/hexane, is often necessary to separate isomers and impurities.[15]
- Crystallization: This is an excellent method for obtaining highly pure material.[14] However, finding the right solvent system can be challenging due to the altered solubility of fluorinated molecules. Test a range of solvents from nonpolar (hexane) to polar (methanol) to find one that dissolves the compound when hot but not when cold.[14]
- Fluorous Solid-Phase Extraction (F-SPE): This specialized technique uses fluorous interactions for highly selective separation and can be very effective for cleaning up samples before final purification.[14]

## Visualizing Reaction Pathways and Workflows

### Troubleshooting Workflow for Low Yield

This diagram outlines a logical sequence of steps to diagnose and resolve low reaction yields.

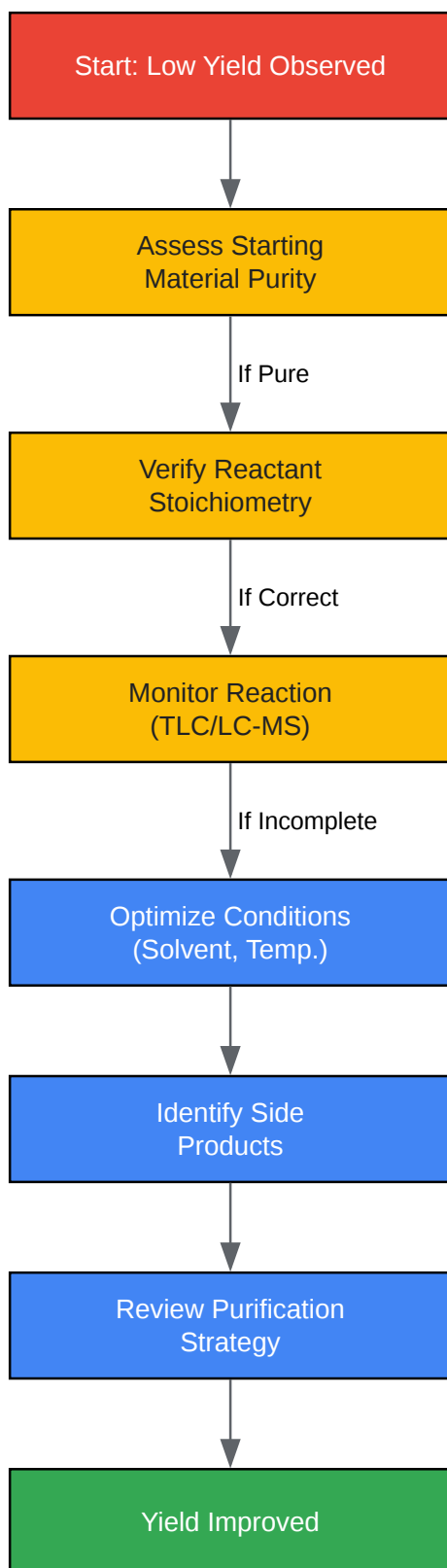

[Click to download full resolution via product page](#)

Caption: A logical workflow for troubleshooting low pyrazole yield.

## Regioselectivity in Pyrazole Synthesis

This diagram illustrates the reaction of an unsymmetrical trifluoromethyl- $\beta$ -diketone with a substituted hydrazine, leading to two potential regioisomers.

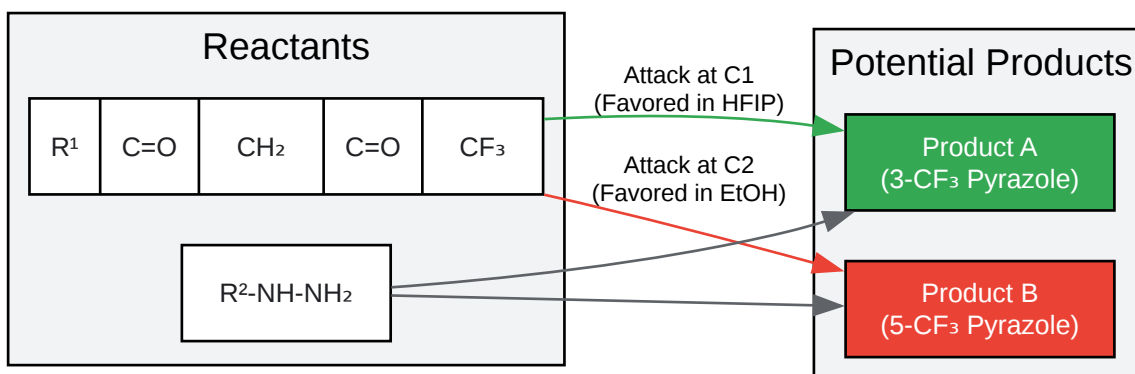

[Click to download full resolution via product page](#)

### Need Custom Synthesis?

BenchChem offers custom synthesis for rare earth carbides and specific isotopic labeling.

Email: [info@benchchem.com](mailto:info@benchchem.com) or [Request Quote Online](#).

## References

1. Trifluoromethylated Pyrazoles via Sequential (3 + 2)-Cycloaddition of Fluorinated Nitrile Imines with Chalcones and Solvent-Dependent Deacylative Oxidation Reactions - PMC [[pmc.ncbi.nlm.nih.gov](http://pmc.ncbi.nlm.nih.gov)]
2. Accessing trifluoromethylated SuFEx-able pyrazole via distortion-accelerated 1,3-dipolar cycloadditions - RSC Advances (RSC Publishing) [[pubs.rsc.org](http://pubs.rsc.org)]
3. Fluorinated Heterocyclic Compounds Synthesis, Chemistry, and Applications [[cincinnatistate.ecampus.com](http://cincinnatistate.ecampus.com)]
4. Fluorinated Heterocyclic Compounds : Synthesis, Chemistry, and Applications [[cincinnatistate.ecampus.com](http://cincinnatistate.ecampus.com)]
5. [benchchem.com](http://benchchem.com) [[benchchem.com](http://benchchem.com)]
6. [benchchem.com](http://benchchem.com) [[benchchem.com](http://benchchem.com)]

- 7. Synthesis and Pharmacological Activities of Pyrazole Derivatives: A Review - PMC [[pmc.ncbi.nlm.nih.gov](https://pubmed.ncbi.nlm.nih.gov/)]
- 8. Synthesis of Perfluoroalkylated Pyrazoles from  $\alpha$ -Perfluoroalkenylated Aldehydes - PMC [[pmc.ncbi.nlm.nih.gov](https://pubmed.ncbi.nlm.nih.gov/)]
- 9. [pubs.acs.org](https://pubs.acs.org) [[pubs.acs.org](https://pubs.acs.org)]
- 10. [mdpi.com](https://mdpi.com) [[mdpi.com](https://mdpi.com)]
- 11. [pubs.acs.org](https://pubs.acs.org) [[pubs.acs.org](https://pubs.acs.org)]
- 12. Regiocontrolled Synthesis of 1-Substituted-3(5)-carboxyalkyl-1H-pyrazoles Using Trichloromethyl Enones - PMC [[pmc.ncbi.nlm.nih.gov](https://pubmed.ncbi.nlm.nih.gov/)]
- 13. [mdpi.com](https://mdpi.com) [[mdpi.com](https://mdpi.com)]
- 14. [benchchem.com](https://benchchem.com) [[benchchem.com](https://benchchem.com)]
- 15. [mdpi.com](https://mdpi.com) [[mdpi.com](https://mdpi.com)]
- To cite this document: BenchChem. [Technical Support Center: Optimizing Trifluoromethyl Pyrazole Synthesis]. BenchChem, [2026]. [Online PDF]. Available at: [<https://www.benchchem.com/product/b574069/docs#technical-support-center-optimizing-trifluoromethyl-pyrazole-synthesis>]

---

### Disclaimer & Data Validity:

The information provided in this document is for Research Use Only (RUO) and is strictly not intended for diagnostic or therapeutic procedures. While BenchChem strives to provide accurate protocols, we make no warranties, express or implied, regarding the fitness of this product for every specific experimental setup.

**Technical Support:** The protocols provided are for reference purposes. Unsure if this reagent suits your experiment?

**Need Industrial/Bulk Grade?** [Request Custom Synthesis Quote](#)

# BenchChem

Our mission is to be the trusted global source of essential and advanced chemicals, empowering scientists and researchers to drive progress in science and industry.

## Contact

Address: 3281 E Guasti Rd

Ontario, CA 91761, United States

Phone: (601) 213-4426

Email: [info@benchchem.com](mailto:info@benchchem.com)

[Contact our Ph.D. Support Team for a compatibility check](#)