

Catalyst selection for optimizing imidazole ring formation

Author: BenchChem Technical Support Team. **Date:** May 2026

Compound of Interest

Compound Name: 1-(10-Hydroxydecyl)imidazole

CAS No.: 186788-38-5

Cat. No.: B573433

[Get Quote](#)

Imidazole Synthesis Optimization Hub

Status: Operational | Version: 2.4.1 | Focus: Catalyst Selection & Process Troubleshooting

Diagnostic Logic: Route & Catalyst Selection

Before selecting a catalyst, you must validate your synthetic route based on substrate availability and substitution requirements. Use this logic gate to determine the optimal catalytic system.

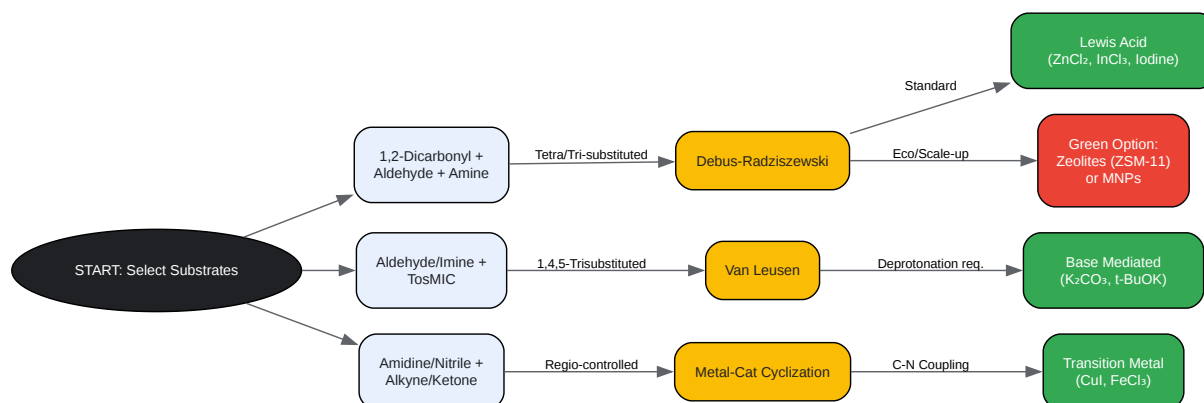

[Click to download full resolution via product page](#)

Figure 1: Decision matrix for selecting the primary catalytic route based on starting materials and desired substitution patterns.

Technical Knowledge Base: Catalyst Mechanisms

A. Lewis Acid Catalysis (Debus-Radziszewski)

Mechanism: Lewis acids (e.g., ZnCl₂, InCl₃, Iodine) activate the carbonyl oxygen of the aldehyde and the 1,2-dicarbonyl. This polarization facilitates the nucleophilic attack by ammonia/amines, accelerating the rate-limiting imine formation step.

- Why it fails: Strong Lewis acids can decompose sensitive aldehydes.
- Optimization: For acid-sensitive substrates, use mild catalysts like Molecular Iodine (I₂) or Silica-supported SbCl₃ [1][2].

B. Base-Mediated Synthesis (Van Leusen)

Mechanism: This reaction relies on the deprotonation of TosMIC (Tosylmethyl Isocyanide) to form a carbanion, which attacks the imine.

- Critical Factor: The choice of base determines the equilibrium of the TosMIC anion. K_2CO_3 is standard, but *t*-BuOK is required for sterically hindered substrates [3][4].

C. Metal-Catalyzed Cyclization

Mechanism: Transition metals (Cu, Fe) often act via dual activation—activating the nitrile/amidine for nucleophilic attack while stabilizing intermediates.

- Recent Advance: Magnetic Nanoparticles (Fe_3O_4) offer a reusable, heterogeneous alternative that mimics Lewis acid behavior but allows for magnetic separation [5].

Troubleshooting & Optimization (Q&A)

Issue 1: Low Yield in Multicomponent Reactions (Debus-Radziszewski)

User Question: I am running a standard 4-component reaction (Benzil + Aldehyde + NH_4OAc + Amine) using acetic acid, but yields are stuck at 40-50%.

Diagnostic:

- Steric Hindrance: Is your aldehyde bulky (e.g., ortho-substituted)?
- Imine Instability: The intermediate diimine may be hydrolyzing before ring closure.

Solution:

- Switch Catalyst: Move from Brønsted acids ($AcOH$) to a Lewis Acid like $Zn(OAc)_2$ or $InCl_3$ (10-20 mol%). These coordinate to the imine nitrogen, stabilizing it against hydrolysis.
- Protocol Adjustment: Adopt a Microwave-Assisted protocol. Irradiation (300W, 80-100°C) often pushes the reaction to completion in minutes rather than hours, bypassing decomposition pathways [6].

Issue 2: Oxazole Contamination (Van Leusen)

User Question: My Van Leusen reaction (Aldehyde + TosMIC) contains ~30% oxazole byproduct.

Diagnostic: This occurs when TosMIC reacts directly with the aldehyde oxygen instead of the imine nitrogen.

Solution:

- Two-Step Protocol: Do not mix all reagents at once. Pre-form the imine by stirring the aldehyde and amine (with dehydrating agent like MgSO_4) for 2 hours before adding TosMIC and base.
- Base Selection: Switch to a weaker base (e.g., K_2CO_3 in MeOH) if using the one-pot method, as strong bases can promote direct attack on the aldehyde [4].

Issue 3: Regioselectivity in N-Alkylation

User Question: I am alkylating an unsymmetrical imidazole and getting a 1:1 mixture of N1 and N3 isomers.

Diagnostic: The imidazole anion delocalizes charge across both nitrogens.[1] Sterics usually dictate the ratio, but electronic effects can interfere.

Solution:

- Steric Control: Use a bulky protecting group like SEM (2-(Trimethylsilyl)ethoxymethyl).[1] It will preferentially attach to the less hindered nitrogen.
- Catalytic Control: Switch to Transition-Metal Catalysis.
 - Palladium (Pd): Generally favors C5-arylation or specific N-arylation patterns based on ligand bulk [7].
 - Nickel (Ni): Can direct C-H activation to the C2 position, altering the reactive landscape for subsequent steps [7].[1]

Validated Experimental Protocols

Protocol A: High-Efficiency Lewis Acid Catalysis (General Purpose)

Best for: Trisubstituted and Tetrasubstituted Imidazoles.

- Setup: In a round-bottom flask, combine:
 - 1,2-Diketone (e.g., Benzil, 1.0 mmol)
 - Aldehyde (1.0 mmol)
 - Ammonium Acetate (2.5 - 4.0 mmol)
 - Catalyst: Molecular Iodine (I_2) (5 mol%) or $Zn(OAc)_2$ (10 mol%).
- Solvent: Add Ethanol (5 mL). Note: Methanol is a viable alternative.
- Reaction: Reflux at 80°C for 45-90 minutes. Monitor via TLC (Ethyl Acetate:Hexane 3:7).
- Quench: Cool to room temperature. Pour mixture into crushed ice containing a small amount of Sodium Thiosulfate (if using Iodine) to quench excess catalyst.
- Purification: Filter the precipitate. Recrystallize from hot ethanol.
 - Expected Yield: >85% [1][8].[2][3]

Protocol B: Green Synthesis with Reusable Catalyst

Best for: Sustainable/Scale-up applications.

- Catalyst Preparation: Use ZSM-11 Zeolite (calcined).
- Reaction: Mix Benzil (1 mmol), Aldehyde (1 mmol), and NH_4OAc (2 mmol) in a mortar.
- Catalysis: Add ZSM-11 (0.1g). Grind the mixture (Solvent-Free) or use minimal Ethanol.
- Heating: Heat at 80°C (oil bath) or Microwave (300W) for 10-15 mins.

- Workup: Add hot ethanol and filter while hot. The ZSM-11 remains on the filter and can be reactivated (washed with dilute HCl, calcined) for reuse up to 5 times [9].
- Isolation: Cool the filtrate to crystallize the product.

Comparative Data: Catalyst Performance

Catalyst Class	Specific Catalyst	Typical Yield	Reaction Time	Key Advantage	Key Limitation
Lewis Acid	Iodine (I ₂)	90-95%	30-60 min	Cheap, Metal-free, High Yield	Requires thiosulfate quench
Lewis Acid	ZnCl ₂ / Zn(OAc) ₂	85-92%	1-2 hrs	Mild, Compatible with many functional groups	Zinc waste disposal
Solid Acid	ZSM-11 Zeolite	88-94%	15-45 min	Reusable, Green, Solvent-free option	Mass transfer limits in solid phase
Base	K ₂ CO ₃ / t- BuOK	75-85%	2-4 hrs	Essential for Van Leusen route	Sensitive to moisture (t- BuOK)
Nano-Metal	Fe ₃ O ₄ MNPs	90-96%	10-30 min	Magnetic separation, High surface area	Synthesis of catalyst is complex

References

- Sharma, N., et al. (2016).[4] "A Schiff's base complex nickel catalyst (Ni-C) enables a highly efficient one-pot microwave-assisted synthesis of 2,4,5-trisubstituted imidazoles." [4] Synlett, 27, 404-408.[4]

- Bagwan, S. M., et al. (2023).[5] "A Simple, Efficient and Green Procedure for the Synthesis of 2, 4, 5-Trisubstituted Imidazole Derivatives Using Novel PEG-SOCl as a Catalyst." International Journal of Pharmaceutical Sciences and Research.
- Van Leusen, D., et al. (1977).[6] "Chemistry of sulfonylmethyl isocyanides. A general one-step synthesis of nitriles from ketones using tosylmethyl isocyanide." [6] Journal of Organic Chemistry, 42(19), 3114–3118.[6]
- Organic Chemistry Portal. "Van Leusen Imidazole Synthesis."
- Kermanizadeh, et al. (2023).[2] "Modified silica-coated cobalt ferrite nano-particles for the synthesis of trisubstituted imidazoles." Scientific Reports.[2]
- Oriental Journal of Chemistry. (2024). "Optimization of Microwave Assisted Synthesis of Substituted Imidazoles – A Green Approach."
- BenchChem Technical Support. (2025). "Enhancing Regioselectivity of Imidazole Substitution Reactions."
- Royal Society of Chemistry. (2021). "Simple practical method for synthesis of trisubstituted imidazoles: an efficient copper catalyzed multicomponent reaction."
- Royal Society of Chemistry. (2022). "An efficient green protocol for the synthesis of 1,2,4,5-tetrasubstituted imidazoles in the presence of ZSM-11 zeolite as a reusable catalyst."

Need Custom Synthesis?

BenchChem offers custom synthesis for rare earth carbides and specific isotopic labeling.

Email: info@benchchem.com or [Request Quote Online](#).

Sources

- 1. pdf.benchchem.com [pdf.benchchem.com]
- 2. [Synthesis of Imidazole-Based Molecules under Ultrasonic Irradiation Approaches](#) [mdpi.com]
- 3. researchgate.net [researchgate.net]

- [4. Imidazole synthesis \[organic-chemistry.org\]](#)
- [5. ijpsr.com \[ijpsr.com\]](#)
- [6. Van Leusen reaction - Wikipedia \[en.wikipedia.org\]](#)
- To cite this document: BenchChem. [Catalyst selection for optimizing imidazole ring formation]. BenchChem, [2026]. [Online PDF]. Available at: [\[https://www.benchchem.com/product/b573433/docs#catalyst-selection-for-optimizing-imidazole-ring-formation\]](https://www.benchchem.com/product/b573433/docs#catalyst-selection-for-optimizing-imidazole-ring-formation)

Disclaimer & Data Validity:

The information provided in this document is for Research Use Only (RUO) and is strictly not intended for diagnostic or therapeutic procedures. While BenchChem strives to provide accurate protocols, we make no warranties, express or implied, regarding the fitness of this product for every specific experimental setup.

Technical Support: The protocols provided are for reference purposes. Unsure if this reagent suits your experiment?

Need Industrial/Bulk Grade? [Request Custom Synthesis Quote](#)

BenchChem

Our mission is to be the trusted global source of essential and advanced chemicals, empowering scientists and researchers to drive progress in science and industry.

Contact

Address: 3281 E Guasti Rd
Ontario, CA 91761, United States
Phone: (601) 213-4426
Email: info@benchchem.com

[Contact our Ph.D. Support Team for a compatibility check](#)

