

Technical Support Center: Optimizing Temperature for Biphenyl Acid Synthesis

Author: BenchChem Technical Support Team. **Date:** May 2026

Compound of Interest

Compound Name: 4-(2-Chloro-5-methylphenyl)-3-methylbenzoic acid

CAS No.: 1365272-40-7

Cat. No.: B572574

[Get Quote](#)

Welcome to the technical support center for biphenyl acid synthesis. This guide is designed for researchers, scientists, and drug development professionals to navigate the nuances of temperature optimization in common synthetic routes. Instead of a rigid protocol, this resource provides in-depth, field-proven insights to empower you to troubleshoot and refine your experimental conditions effectively.

Troubleshooting Guide: Common Temperature-Related Issues

This section addresses specific problems you might encounter during your biphenyl acid synthesis, with a focus on temperature as a critical parameter.

Question 1: My Suzuki-Miyaura coupling reaction is giving a low yield of the desired biphenyl acid. How can I optimize the temperature to improve this?

Answer:

A low yield in a Suzuki-Miyaura coupling is a frequent challenge, and temperature is a pivotal variable to investigate. The optimal temperature is often a delicate balance. It needs to be high enough to drive the catalytic cycle forward efficiently but not so high that it leads to catalyst decomposition or undesirable side reactions.

Causality-Driven Troubleshooting Steps:

- **Initial Temperature Assessment:** The ideal temperature is highly dependent on your specific substrates, catalyst, and solvent system. For many standard Suzuki couplings using palladium catalysts like Pd(PPh₃)₄ or Pd/C, a temperature range of 70-110°C is a good starting point.^{[1][2]} Some reactions can even be performed at room temperature, though this may significantly increase the required reaction time.^{[3][4]}
- **Stepwise Temperature Increase:** If your yield is low at a moderate temperature (e.g., 70°C), a systematic, stepwise increase in temperature is a logical next step. Increasing the temperature can lead to higher conversion percentages.^{[1][3]} Monitor your reaction at increments of 10-15°C (e.g., 80°C, 95°C, 110°C). It's crucial to monitor the reaction progress at each temperature point using a suitable analytical technique like TLC or LC-MS to identify the point of optimal conversion without significant impurity formation.
- **Consider the Solvent's Boiling Point:** The reaction temperature should not exceed the boiling point of your solvent under the reaction pressure. For instance, if you are using a solvent mixture like DMF/H₂O, the temperature should be controlled accordingly.^{[1][3]}
- **Catalyst Stability:** Be mindful of your catalyst's thermal stability. While higher temperatures can increase reaction rates, excessive heat can lead to the decomposition of the palladium catalyst, which will halt the reaction. If you observe the formation of black palladium precipitate, it's a sign of catalyst decomposition, and you should consider running the reaction at a lower temperature or choosing a more thermally stable catalyst.
- **Microwave Synthesis for Rapid Optimization:** If available, microwave-assisted synthesis can be a powerful tool for rapidly screening optimal temperature conditions. The precise temperature control and rapid heating offered by microwave reactors can significantly shorten reaction times and improve yields.

Question 2: I am observing a significant amount of homocoupling byproducts in my reaction mixture. Can temperature adjustments help minimize this side reaction?

Answer:

Yes, temperature control is a key factor in minimizing homocoupling, a common side reaction where two molecules of the same starting material couple together.

Strategies to Mitigate Homocoupling via Temperature Control:

- **Lowering the Reaction Temperature:** Elevated temperatures can sometimes favor the homocoupling pathway.^[5] If you are experiencing significant homocoupling, try reducing the reaction temperature. This can slow down the rate of the undesired side reaction more than the desired cross-coupling reaction, thus improving the selectivity for your biphenyl acid product.
- **Controlled Addition of Reagents:** While not a direct temperature manipulation of the bulk reaction, controlling the temperature during the addition of reagents can be critical. For instance, in reactions involving highly reactive intermediates like Grignard reagents, a slow, controlled addition at a lower temperature can prevent localized high concentrations and a spike in temperature that could promote homocoupling.
- **Optimize Other Parameters in Conjunction with Temperature:** It's important to remember that temperature is just one piece of the puzzle. The choice of base, solvent, and catalyst all interact with temperature to influence the reaction outcome. For example, a stronger base might allow for a lower reaction temperature, which in turn could suppress homocoupling.

Question 3: My Ullmann condensation for biphenyl acid synthesis is not proceeding to completion. What is the recommended temperature range for this reaction?

Answer:

The Ullmann reaction traditionally requires more forcing conditions than many modern cross-coupling reactions.

Temperature Considerations for the Ullmann Reaction:

- **High-Temperature Requirement:** The Ullmann reaction is well-known for requiring high temperatures, often in the range of 100°C to over 200°C.[6][7][8] The specific temperature will depend on the reactivity of your aryl halides and the copper catalyst used.
- **Solvent Choice Dictates Temperature:** The choice of a high-boiling point polar aprotic solvent is crucial for achieving the necessary reaction temperatures. Solvents like DMF, N-methylpyrrolidone (NMP), or nitrobenzene are commonly used.[7]
- **Catalyst Activation:** The nature of the copper catalyst is also a factor. "Activated" copper powder may allow for slightly lower reaction temperatures.[7]
- **Monitoring and Reaction Time:** Due to the high temperatures and often heterogeneous nature of the reaction, it's important to ensure efficient stirring and to monitor the reaction over a sufficient period. These reactions can sometimes require several hours to reach completion.

Frequently Asked Questions (FAQs)

Q1: What is a typical starting temperature for a Suzuki-Miyaura reaction to synthesize biphenyl acid?

A1: A good starting point for many Suzuki-Miyaura reactions for biphenyl acid synthesis is around 80-100°C.[9][10] However, this is highly dependent on the specific substrates, catalyst, and solvent system. It is always recommended to perform a small-scale test reaction to determine the optimal temperature for your specific conditions.

Q2: How does temperature affect the reaction kinetics of the Suzuki-Miyaura coupling?

A2: As with most chemical reactions, increasing the temperature generally increases the reaction rate of the Suzuki-Miyaura coupling.[3][11] This is because higher temperatures provide the molecules with more kinetic energy, leading to more frequent and energetic collisions, which in turn increases the likelihood of a successful reaction. However, as

mentioned earlier, there is an optimal temperature beyond which catalyst decomposition and side reactions can become significant.

Q3: Can the synthesis of biphenyl acid be performed at room temperature?

A3: Yes, under certain conditions, the synthesis of biphenyl acid via Suzuki-Miyaura coupling can be achieved at room temperature.^[4] This typically requires a highly active catalyst system and may necessitate longer reaction times. Room temperature reactions are advantageous for substrates that are sensitive to heat.

Q4: Are there any safety considerations related to temperature in biphenyl acid synthesis?

A4: Yes, safety is paramount. When working with heated reactions, always use a well-calibrated heating mantle or oil bath with a temperature controller and a secondary containment system. Ensure that your reaction vessel is appropriate for the temperature and pressure and that the setup is in a well-ventilated fume hood. Be aware of the flash points of your solvents to prevent fires.

Data Summary: Temperature Effects in Biphenyl Synthesis

Reaction Type	Common Temperature Range (°C)	Effect of Increasing Temperature	Potential Issues with Excessive Temperature
Suzuki-Miyaura Coupling	70 - 110	Increased reaction rate and yield (up to an optimum) ^{[1][3]}	Catalyst decomposition, increased side reactions (e.g., homocoupling), solvent evaporation.
Ullmann Condensation	100 - 250	Drives the reaction forward, necessary for less reactive substrates. ^{[6][7]}	Decomposition of starting materials and product, significant byproduct formation.

Experimental Protocol: Temperature Optimization for a Generic Suzuki-Miyaura Coupling

This protocol outlines a general procedure for optimizing the temperature for the synthesis of a biphenyl acid derivative.

Materials:

- Aryl halide (e.g., 4-bromobenzoic acid)
- Arylboronic acid (e.g., phenylboronic acid)
- Palladium catalyst (e.g., Pd(PPh₃)₄ or 10% Pd/C)
- Base (e.g., K₂CO₃ or Na₂CO₃)
- Solvent (e.g., a mixture of 1,4-dioxane and water)
- Round-bottom flask equipped with a reflux condenser and magnetic stirrer
- Heating mantle or oil bath with a temperature controller
- TLC plates and developing chamber
- LC-MS for in-process control (recommended)

Procedure:

- **Reaction Setup:** In a round-bottom flask, combine the aryl halide (1.0 eq), arylboronic acid (1.2 eq), base (2.0-3.0 eq), and palladium catalyst (0.01-0.05 eq).
- **Solvent Addition:** Add the chosen solvent system to the flask.
- **Initial Temperature:** Set the heating mantle or oil bath to the lower end of the typical range for your catalyst and solvent system (e.g., 70°C).
- **Reaction Monitoring:** Stir the reaction mixture and monitor its progress every 30-60 minutes using TLC or LC-MS. Note the formation of the product and the consumption of the starting

materials.

- **Stepwise Temperature Increase:** If the reaction is sluggish or the conversion is low after a few hours, increase the temperature by 10-15°C.
- **Continued Monitoring:** Continue to monitor the reaction at the new temperature. Look for an increase in the rate of product formation. Also, be vigilant for the appearance of new, significant impurity spots on the TLC plate.
- **Identify Optimal Temperature:** The optimal temperature is the one that provides a good reaction rate and high conversion to the desired product with minimal formation of byproducts.
- **Work-up and Analysis:** Once the reaction is complete, cool the mixture to room temperature and perform an appropriate work-up procedure to isolate the crude product. Analyze the crude product by NMR and/or LC-MS to determine the yield and purity.

Visualizing Reaction Pathways and Workflows

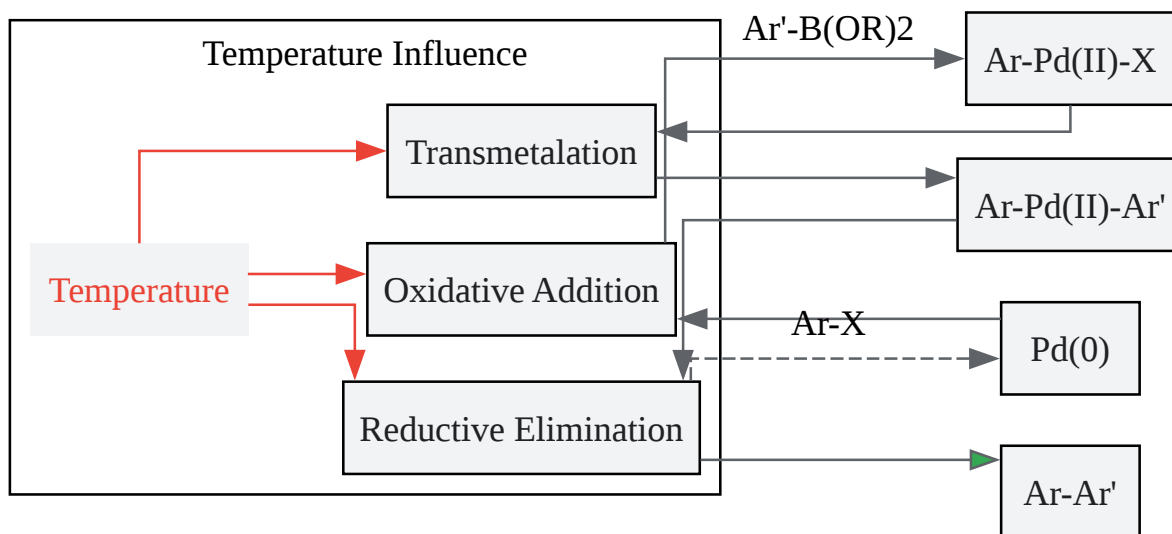

[Click to download full resolution via product page](#)

Caption: The Suzuki-Miyaura catalytic cycle is influenced by temperature at multiple stages.

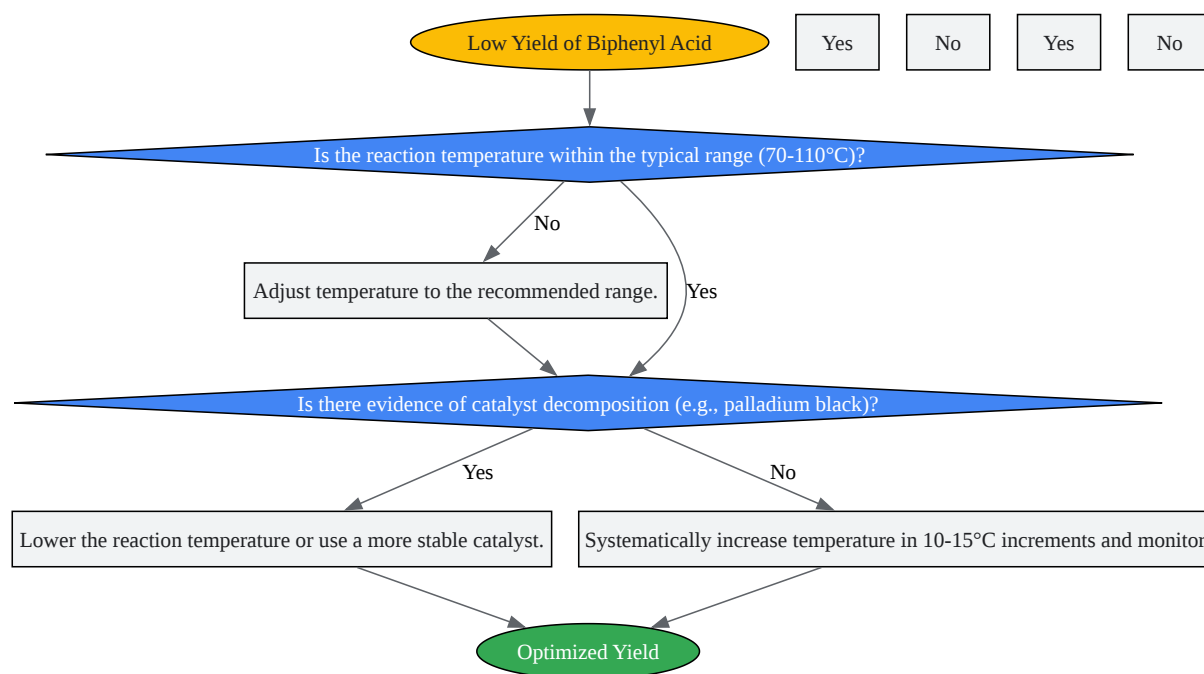

[Click to download full resolution via product page](#)

Caption: A troubleshooting workflow for addressing low yields in biphenyl acid synthesis.

References

- Design of Experiment Optimisation of the Suzuki Cross-Coupling: A Synthesis of Biphenyl, Catalysed by Palladium Tetrakis, from.
- Optimizing Suzuki Coupling Reactions - CovaSyn.
- Kinetic Aspects of Suzuki Cross-Coupling Using Ligandless Pd Nanoparticles Embedded in Aromatic Polymeric Matrix - MDPI. Available at: [\[Link\]](#)

- US5756724A - High-yielding ullmann reaction for the preparation of bipyrrroles - Google Patents.
- General Ullman cross-coupling reaction for the synthesis of biphenyl derivatives.
- Suzuki-Miyaura C-C Coupling Reactions Catalyzed by Supported Pd Nanoparticles for the Preparation of Fluorinated Biphenyl Derivatives - MDPI. Available at: [\[Link\]](#)
- Ullmann condensation - Wikipedia. Available at: [\[Link\]](#)
- The effect of various temperatures on the Suzuki coupling reaction a - ResearchGate. Available at: [\[Link\]](#)
- Multikilogram-Scale Synthesis of a Biphenyl Carboxylic Acid Derivative Using a Pd/C-Mediated Suzuki Coupling Approach - ACS Publications. Available at: [\[Link\]](#)
- Effects on Altering Reaction Conditions in Suzuki Cross Coupling Reactions Using the Microwave - ScholarWorks @ UTRGV. Available at: [\[Link\]](#)
- 4-Aminobiphenyl - Wikipedia. Available at: [\[Link\]](#)
- CN102351620A - Method for preparing biphenyl compound through catalyzing Suzuki coupling reaction by nanometer palladium catalyst - Google Patents.
- US6369271B1 - Process for preparing derivatives of biphenyl-2-carboxylic acid - Google Patents.
- 10.15.5 (Aminomethyl)biphenylcarboxylic Acid Peptides.
- (a) Effect of temperature on the progress of the assisted Suzuki... | Download Scientific Diagram - ResearchGate. Available at: [\[Link\]](#)
- A fruitful century for the scalable synthesis and reactions of biphenyl derivatives: applications and biological aspects - PMC. Available at: [\[Link\]](#)
- CN101367736A - A kind of synthetic method of 2-aminobiphenyl compound - Google Patents.
- Green synthesis of biphenyl carboxylic acids via Suzuki–Miyaura cross-coupling catalyzed by a water-soluble fullerene-supported PdCl₂ nanocatalyst - ResearchGate. Available at: [\[Link\]](#)

- Design and synthesis of biphenyl and biphenyl ether inhibitors of sulfatases - PMC - NIH. Available at: [\[Link\]](#)
- Chemistry Ullmann Reaction - SATHEE. Available at: [\[Link\]](#)
- Ullmann Reaction - BYJU'S. Available at: [\[Link\]](#)

Need Custom Synthesis?

BenchChem offers custom synthesis for rare earth carbides and specific isotopic labeling.

Email: info@benchchem.com or [Request Quote Online](#).

Sources

- 1. [mdpi.com](https://www.mdpi.com) [[mdpi.com](https://www.mdpi.com)]
- 2. pubs.acs.org [pubs.acs.org]
- 3. [researchgate.net](https://www.researchgate.net) [[researchgate.net](https://www.researchgate.net)]
- 4. [researchgate.net](https://www.researchgate.net) [[researchgate.net](https://www.researchgate.net)]
- 5. [benchchem.com](https://www.benchchem.com) [[benchchem.com](https://www.benchchem.com)]
- 6. US5756724A - High-yielding ullmann reaction for the preparation of bipyrrroles - Google Patents [patents.google.com]
- 7. Ullmann condensation - Wikipedia [en.wikipedia.org]
- 8. SATHEE: Chemistry Ullmann Reaction [sathee.iitk.ac.in]
- 9. abstracts.societyforscience.org [abstracts.societyforscience.org]
- 10. [ajgreenchem.com](https://www.ajgreenchem.com) [[ajgreenchem.com](https://www.ajgreenchem.com)]
- 11. [mdpi.com](https://www.mdpi.com) [[mdpi.com](https://www.mdpi.com)]
- To cite this document: BenchChem. [Technical Support Center: Optimizing Temperature for Biphenyl Acid Synthesis]. BenchChem, [2026]. [Online PDF]. Available at: [\[https://www.benchchem.com/product/b572574/docs#technical-support-center-optimizing-temperature-for-biphenyl-acid-synthesis\]](https://www.benchchem.com/product/b572574/docs#technical-support-center-optimizing-temperature-for-biphenyl-acid-synthesis)

Disclaimer & Data Validity:

The information provided in this document is for Research Use Only (RUO) and is strictly not intended for diagnostic or therapeutic procedures. While BenchChem strives to provide accurate protocols, we make no warranties, express or implied, regarding the fitness of this product for every specific experimental setup.

Technical Support: The protocols provided are for reference purposes. Unsure if this reagent suits your experiment?

Need Industrial/Bulk Grade? [Request Custom Synthesis Quote](#)

BenchChem

Our mission is to be the trusted global source of essential and advanced chemicals, empowering scientists and researchers to drive progress in science and industry.

Contact

Address: 3281 E Guasti Rd
Ontario, CA 91761, United States
Phone: (601) 213-4426
Email: info@benchchem.com

[Contact our Ph.D. Support Team for a compatibility check](#)