

# Application Notes and Protocols for AM6545 in Metabolic Research

**Author:** BenchChem Technical Support Team. **Date:** April 2026

## Compound of Interest

Compound Name:	AM6545
CAS No.:	1245626-05-4
Cat. No.:	B570646

[Get Quote](#)

For Researchers, Scientists, and Drug Development Professionals

These application notes provide a comprehensive overview of **AM6545**, a peripherally restricted cannabinoid receptor 1 (CB1) neutral antagonist, and its utility in metabolic research. Detailed protocols for key in vivo experiments are provided to facilitate the design and execution of studies investigating the therapeutic potential of **AM6545** for obesity and related metabolic disorders.

## Introduction

The endocannabinoid system, particularly the CB1 receptor, plays a significant role in regulating energy balance, food intake, and metabolism.[1] While central CB1 receptor antagonists have shown efficacy in reducing body weight, their clinical use has been hampered by neuropsychiatric side effects.[2][3] **AM6545** is a novel CB1 receptor antagonist designed to have limited penetration of the central nervous system (CNS), thereby minimizing centrally-mediated adverse effects.[2][4] It acts as a neutral antagonist, binding to the CB1 receptor without altering its basal signaling activity, which may offer a better safety profile compared to inverse agonists.[2][5] Preclinical studies have demonstrated the potential of **AM6545** to

ameliorate metabolic dysfunction by reducing food intake, body weight, and improving insulin sensitivity.[3][6][7]

## Mechanism of Action

**AM6545** selectively binds to the CB1 receptor with a high affinity ( $K_i$  of 1.7 nM) and has a much lower affinity for the CB2 receptor ( $K_i$  of 523 nM).[2] Its "peripheral restriction" is due to its limited ability to cross the blood-brain barrier.[4] By blocking peripheral CB1 receptors, primarily located in adipose tissue, liver, and the gastrointestinal tract, **AM6545** can modulate metabolic processes without directly impacting the CNS.[6][8] The blockade of these peripheral CB1 receptors is believed to counteract the overactivity of the endocannabinoid system often observed in obesity and metabolic syndrome.[6][9] This leads to a reduction in lipogenesis, an increase in adiponectin levels, and improved glucose homeostasis.[6][8]

## Key Research Findings

**AM6545** has been shown to have beneficial effects on several key metabolic parameters in various rodent models of obesity and metabolic syndrome.

## Effects on Body Weight and Food Intake

Chronic administration of **AM6545** has been demonstrated to reduce body weight gain and food intake.[3][4] In diet-induced obese mice, a daily dose of 10 mg/kg **AM6545** for 28 days significantly counteracted high-fat diet-induced increases in body weight.[8] Similarly, in a monosodium glutamate (MSG)-induced obesity model, 3-week treatment with **AM6545** dose-dependently decreased body weight.[6]

## Effects on Glucose Metabolism and Insulin Sensitivity

**AM6545** treatment has been shown to improve glucose tolerance and insulin sensitivity.[6][8][10] In MSG-induced obese mice, **AM6545** treatment resulted in significantly lower blood glucose levels during an oral glucose tolerance test (OGTT) and reduced fasting insulin levels.[6] Studies in high-fructose, high-salt-fed rats also demonstrated that **AM6545** significantly inhibited the development of insulin resistance.[10][11]

## Effects on Adipose Tissue and Lipid Profile

**AM6545** has been observed to positively impact adipose tissue function and systemic lipid profiles. It can reduce intraperitoneal fat mass and the size of adipocytes.[6][12] Furthermore, **AM6545** treatment has been associated with beneficial changes in circulating adipokines, including increased levels of high molecular weight (HMW) adiponectin and decreased levels of leptin and TNF- $\alpha$ . [6][12] It also helps to rectify dyslipidemia by reducing elevated serum triglycerides and total cholesterol.[6]

## Quantitative Data Summary

The following tables summarize the quantitative data from key preclinical studies investigating the effects of **AM6545** on various metabolic parameters.

Table 1: Effects of **AM6545** on Body Weight and Food Intake in Rodent Models

Animal Model	Treatment Group	Dose (mg/kg)	Duration	Change in Body Weight	Change in Food Intake	Reference
Diet-Induced Obese Mice	AM6545	10	28 days	Significant reduction vs. HFD control	Not specified	[8]
MSG-Induced Obese Mice	AM6545	3	3 weeks	Significant decrease from day 6-13	No significant impact	[6][12]
MSG-Induced Obese Mice	AM6545	10	3 weeks	Significant decrease from day 6-13	Transient reduction in the initial period	[6][12]
Rats on Chow Diet	AM6545	10	7 days	Significant reduction in weight gain from day 4-7	Significant inhibition from day 1-5	[4]

Table 2: Effects of **AM6545** on Glucose Homeostasis in Rodent Models

Animal Model	Treatment Group	Dose (mg/kg)	Test	Key Findings	Reference
Diet-Induced Obese Mice	AM6545	10	OGTT	Improved glucose tolerance	[8]
Diet-Induced Obese Mice	AM6545	10	ITT	Improved insulin sensitivity	[8]
MSG-Induced Obese Mice	AM6545	10	OGTT	Markedly lower blood glucose at 30, 60, 120 min	[6]
MSG-Induced Obese Mice	AM6545	10	Fasting Insulin	Significantly lowered	[6]
High-Fructose/High-Salt Rats	AM6545	10	OGTT	Significantly lower AUC vs. metabolic syndrome group	[10]
High-Fructose/High-Salt Rats	AM6545	10	HOMA-IR	Significantly inhibited increase in insulin resistance	[10][11]

 Table 3: Effects of **AM6545** on Lipid Profile and Adipokines in Rodent Models

Animal Model	Treatment Group	Dose (mg/kg)	Parameter	Change	Reference
Diet-Induced Obese Mice	AM6545	10	Plasma Triglycerides	Significant reduction	[8]
Diet-Induced Obese Mice	AM6545	10	Plasma Cholesterol	Significant reduction	[8]
MSG-Induced Obese Mice	AM6545	10	Serum Triglycerides	Rectified elevation	[6][12]
MSG-Induced Obese Mice	AM6545	10	Serum Total Cholesterol	Rectified elevation	[6][12]
MSG-Induced Obese Mice	AM6545	10	HMW Adiponectin	Increased	[6][12]
MSG-Induced Obese Mice	AM6545	10	Leptin	Lowered	[6][12]
MSG-Induced Obese Mice	AM6545	10	TNF- $\alpha$	Lowered	[6][12]
High-Fructose/High-Salt Rats	AM6545	10	Serum Cholesterol	Significant reduction	[10]
High-Fructose/High-Salt Rats	AM6545	10	Serum Triglycerides	Significant reduction	[10]
High-Fructose/High-Salt Rats	AM6545	10	Adiponectin	Inhibited decrease	[10][11]
High-Fructose/High-Salt Rats	AM6545	10	Liver TNF- $\alpha$	Inhibited increase	[10][11]

## Experimental Protocols

Detailed methodologies for key experiments are provided below. These protocols are based on established methods and can be adapted for studies involving **AM6545**.

## In Vivo Study Design for Metabolic Syndrome Model

This protocol describes a general framework for inducing metabolic syndrome in rats and assessing the therapeutic effects of **AM6545**.

Animals: Male Wistar rats (6 weeks old, weighing 150-190 g).[13]

Housing: Housed at room temperature with a 12:12 h light/dark cycle and free access to a standard rodent diet and water.[13]

Metabolic Syndrome Induction:

- Divide rats into experimental groups (e.g., Control, Metabolic Syndrome, Metabolic Syndrome + **AM6545**).
- The Metabolic Syndrome group receives a high-fructose (20% w/v in drinking water) and high-salt (3% in food pellets) diet for 12 weeks.[9][10][14] The control group receives a standard diet and water.

**AM6545** Administration:

- During the final four weeks of the study, the treatment group receives daily intraperitoneal (i.p.) injections of **AM6545** (e.g., 10 mg/kg).[9][10][14]
- The vehicle control group receives i.p. injections of the vehicle solution (e.g., 1:1:8 dimethyl sulfoxide:emulphor:saline).[15]

Outcome Measures:

- Weekly monitoring of body weight and food/water intake.
- At the end of the study, perform an Oral Glucose Tolerance Test (OGTT) and/or an Insulin Tolerance Test (ITT).

- Collect blood samples for analysis of glucose, insulin, lipids (triglycerides, cholesterol), and adipokines (adiponectin, leptin).
- Harvest tissues (liver, adipose tissue) for histological analysis and measurement of inflammatory markers (e.g., TNF- $\alpha$ ).[\[10\]](#)[\[14\]](#)

## Oral Glucose Tolerance Test (OGTT)

The OGTT is used to assess how quickly glucose is cleared from the blood, providing an indication of glucose tolerance and insulin sensitivity.[\[16\]](#)[\[17\]](#)

Procedure:

- Fast animals for 6-8 hours (mice) or 12-16 hours (rats) with free access to water.[\[6\]](#)[\[17\]](#)[\[18\]](#)
- Record the baseline blood glucose level (t=0) from a tail vein blood sample using a glucometer.[\[16\]](#)
- Administer a glucose solution (e.g., 2 g/kg body weight) via oral gavage.[\[16\]](#)
- Measure blood glucose levels at specific time points after glucose administration (e.g., 15, 30, 60, 90, and 120 minutes).[\[6\]](#)[\[16\]](#)
- Plot the blood glucose concentration over time and calculate the area under the curve (AUC) for a quantitative comparison between groups.[\[10\]](#)

## Insulin Tolerance Test (ITT)

The ITT is a standard method to evaluate systemic insulin sensitivity.[\[19\]](#)

Procedure:

- Fast animals for 4-6 hours.[\[19\]](#)[\[20\]](#)
- Record the baseline blood glucose level (t=0).
- Administer human insulin (e.g., 0.75 U/kg body weight for mice) via intraperitoneal injection.

- Measure blood glucose levels at specific time points after insulin injection (e.g., 15, 30, 45, 60, 90, and 120 minutes).[21]
- Plot the percentage decrease in blood glucose from baseline over time. A greater and more sustained decrease indicates higher insulin sensitivity.

## Body Composition Analysis

Dual-energy X-ray absorptiometry (DEXA) is a non-invasive technique to measure fat mass, lean mass, and bone mineral density, providing a comprehensive assessment of body composition changes.[22]

Procedure:

- Anesthetize the animal according to approved institutional protocols.
- Place the animal in a prone position on the DEXA scanner bed.
- Perform a whole-body scan according to the manufacturer's instructions.
- Analyze the scan data to determine fat mass, lean mass, and bone mineral content.

## Visualizations

### Signaling Pathway

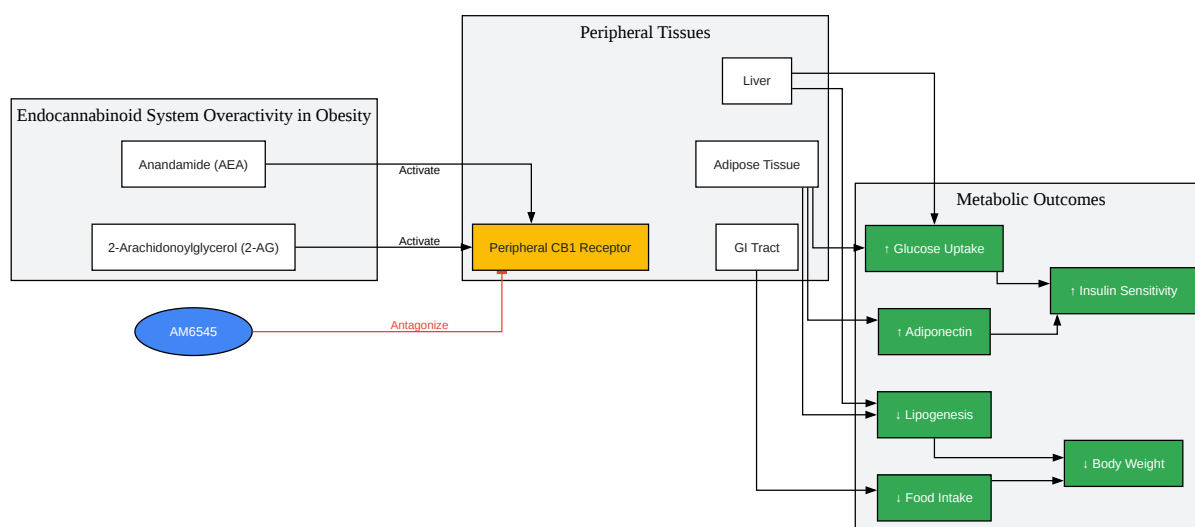

[Click to download full resolution via product page](#)

Caption: **AM6545** antagonizes peripheral CB1 receptors, leading to beneficial metabolic effects.

## Experimental Workflow

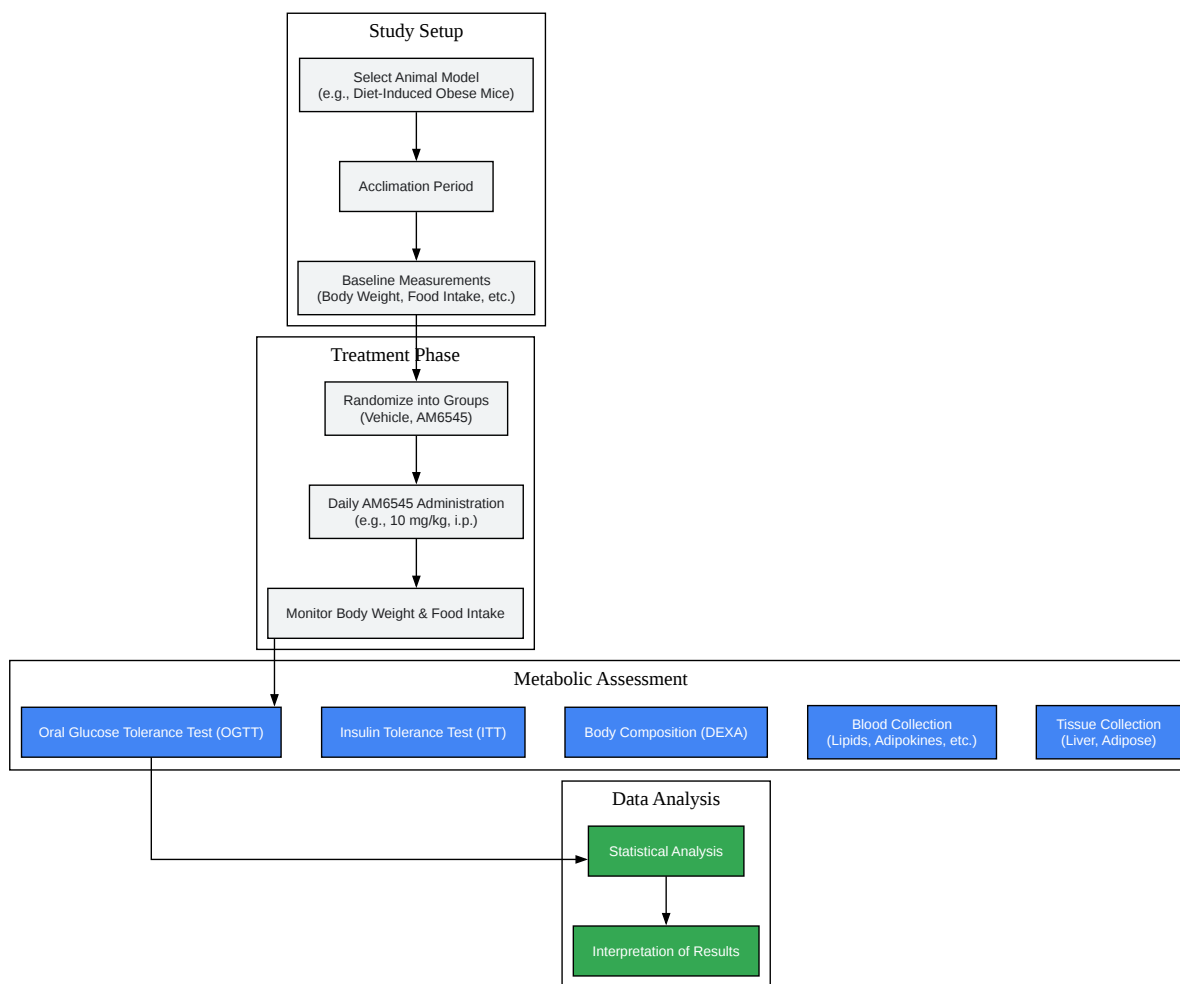

[Click to download full resolution via product page](#)

Caption: A typical experimental workflow for evaluating **AM6545** in metabolic research.

## Logical Relationship

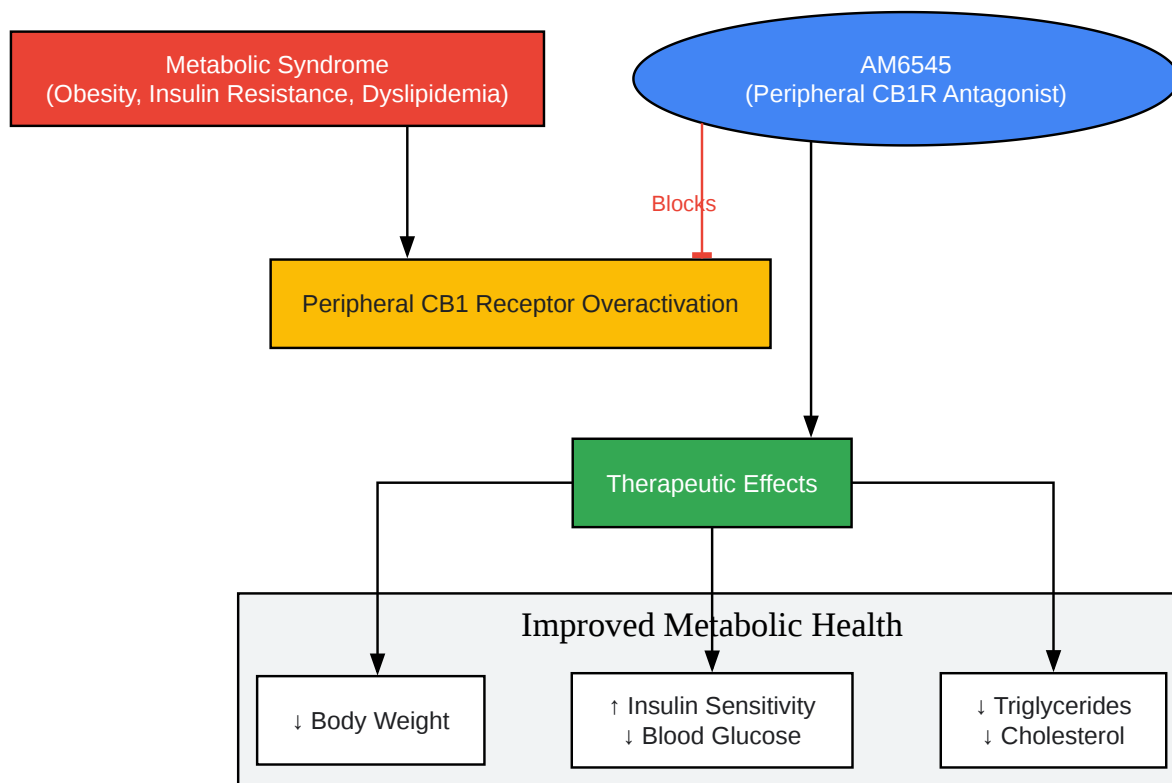

[Click to download full resolution via product page](#)

Caption: Logical relationship of **AM6545** action in metabolic syndrome.

### Need Custom Synthesis?

BenchChem offers custom synthesis for rare earth carbides and specific isotopic labeling.

Email: [info@benchchem.com](mailto:info@benchchem.com) or [Request Quote Online](#).

## References

- 1. [mdpi.com \[mdpi.com\]](https://www.mdpi.com)
- 2. A novel peripherally restricted cannabinoid receptor antagonist, AM6545, reduces food intake and body weight, but does not cause malaise, in rodents - PubMed [[pubmed.ncbi.nlm.nih.gov](https://pubmed.ncbi.nlm.nih.gov)]

- [3. researchgate.net \[researchgate.net\]](#)
- [4. A novel peripherally restricted cannabinoid receptor antagonist, AM6545, reduces food intake and body weight, but does not cause malaise, in rodents - PMC \[pmc.ncbi.nlm.nih.gov\]](#)
- [5. THE NOVEL CANNABINOID CB1 ANTAGONIST AM6545 SUPPRESSES FOOD INTAKE AND FOOD-REINFORCED BEHAVIOR - PMC \[pmc.ncbi.nlm.nih.gov\]](#)
- [6. Frontiers | Peripheral CB1 Receptor Neutral Antagonist, AM6545, Ameliorates Hypometabolic Obesity and Improves Adipokine Secretion in Monosodium Glutamate Induced Obese Mice \[frontiersin.org\]](#)
- [7. realmofcaring.org \[realmofcaring.org\]](#)
- [8. JCI - Peripheral CB1 cannabinoid receptor blockade improves cardiometabolic risk in mouse models of obesity \[jci.org\]](#)
- [9. Effects of the CB1 receptor antagonists AM6545 and AM4113 on metabolic syndrome-induced prostatic hyperplasia in rats - PMC \[pmc.ncbi.nlm.nih.gov\]](#)
- [10. Effects of the CB1 Receptor Antagonists AM6545 and AM4113 on Insulin Resistance in a High-Fructose High-Salt Rat Model of Metabolic Syndrome - PMC \[pmc.ncbi.nlm.nih.gov\]](#)
- [11. Effects of the CB1 Receptor Antagonists AM6545 and AM4113 on Insulin Resistance in a High-Fructose High-Salt Rat Model of Metabolic Syndrome - PubMed \[pubmed.ncbi.nlm.nih.gov\]](#)
- [12. Peripheral CB1 Receptor Neutral Antagonist, AM6545, Ameliorates Hypometabolic Obesity and Improves Adipokine Secretion in Monosodium Glutamate Induced Obese Mice - PMC \[pmc.ncbi.nlm.nih.gov\]](#)
- [13. researchgate.net \[researchgate.net\]](#)
- [14. Effects of the CB1 Receptor Antagonists AM6545 and AM4113 on Insulin Resistance in a High-Fructose High-Salt Rat Model of Metabolic Syndrome \[mdpi.com\]](#)
- [15. Peripherally restricted cannabinoid type 1 receptor \(CB1R\) antagonist, AM6545, potentiates stress-induced hypothalamic–pituitary–adrenal axis activation via a non-CB1R mechanism - PMC \[pmc.ncbi.nlm.nih.gov\]](#)
- [16. Glucose Tolerance Test \[protocols.io\]](#)
- [17. Glucose Tolerance Test - StatPearls - NCBI Bookshelf \[ncbi.nlm.nih.gov\]](#)
- [18. PhenX Toolkit: Protocols \[phenxtoolkit.org\]](#)
- [19. Insulin Tolerance Test \[protocols.io\]](#)
- [20. Insulin Tolerance Test in Mouse \[protocols.io\]](#)

- [21. Guidelines and Considerations for Metabolic Tolerance Tests in Mice - PMC \[pmc.ncbi.nlm.nih.gov\]](#)
- [22. Body composition techniques - PMC \[pmc.ncbi.nlm.nih.gov\]](#)
- To cite this document: BenchChem. [Application Notes and Protocols for AM6545 in Metabolic Research]. BenchChem, [2026]. [Online PDF]. Available at: [\[https://www.benchchem.com/product/b570646/docs#application-notes-and-protocols-for-am6545-in-metabolic-research\]](https://www.benchchem.com/product/b570646/docs#application-notes-and-protocols-for-am6545-in-metabolic-research)

---

**Disclaimer & Data Validity:**

The information provided in this document is for Research Use Only (RUO) and is strictly not intended for diagnostic or therapeutic procedures. While BenchChem strives to provide accurate protocols, we make no warranties, express or implied, regarding the fitness of this product for every specific experimental setup.

**Technical Support:** The protocols provided are for reference purposes. Unsure if this reagent suits your experiment?

**Need Industrial/Bulk Grade?** [Request Custom Synthesis Quote](#)

## BenchChem

Our mission is to be the trusted global source of essential and advanced chemicals, empowering scientists and researchers to drive progress in science and industry.

### Contact

Address: 3281 E Guasti Rd  
Ontario, CA 91761, United States  
Phone: (601) 213-4426  
Email: [info@benchchem.com](mailto:info@benchchem.com)

[Contact our Ph.D. Support Team for a compatibility check](#)

