

A Comparative Guide to the Enantioselectivity of Osmium Catalysts

Author: BenchChem Technical Support Team. **Date:** December 2025

Compound of Interest

Compound Name: *Potassium osmate(VI) dihydrate*

Cat. No.: B570676

[Get Quote](#)

For Researchers, Scientists, and Drug Development Professionals

The quest for enantiomerically pure compounds is a cornerstone of modern chemistry, particularly in the pharmaceutical industry where the chirality of a molecule can dictate its efficacy and safety. Osmium-catalyzed asymmetric reactions, most notably the Sharpless Asymmetric Dihydroxylation (AD) and Asymmetric Aminohydroxylation (AA), have emerged as powerful and reliable methods for the stereoselective synthesis of chiral diols and amino alcohols. These products are invaluable building blocks in the synthesis of a vast array of complex molecules, including natural products and therapeutic agents.

This guide provides an objective comparison of the performance of different osmium catalyst systems, with a focus on the enantioselectivity achieved in asymmetric dihydroxylation and aminohydroxylation reactions. The data presented is compiled from peer-reviewed literature and is intended to assist researchers in selecting the optimal catalyst and reaction conditions for their specific synthetic challenges.

Performance Comparison of Osmium Catalysts in Asymmetric Dihydroxylation

The Sharpless Asymmetric Dihydroxylation has become the benchmark for the enantioselective synthesis of vicinal diols from olefins. The most widely used catalyst systems are the commercially available "AD-mix" formulations, which contain a catalytic amount of potassium osmate ($K_2OsO_2(OH)_4$), a stoichiometric re-oxidant (potassium ferricyanide, $K_3Fe(CN)_6$), a

base (potassium carbonate, K_2CO_3), and a chiral ligand.[1] The choice of the chiral ligand, a derivative of either dihydroquinine (DHQ) or dihydroquinidine (DHQD), dictates the facial selectivity of the dihydroxylation and thus the absolute configuration of the resulting diol.[2]

The two most common ligands are $(DHQ)_2PHAL$ and $(DHQD)_2PHAL$, which are the chiral components of AD-mix- α and AD-mix- β , respectively.[3] These ligands are considered pseudoenantiomeric and generally deliver the opposite enantiomer of the diol product.[4]

Table 1: Enantioselectivity of AD-mix- α vs. AD-mix- β in the Dihydroxylation of Substituted Styrenes[4]

Substrate	Ligand System	Yield (%)	ee (%)	Configuration
Styrene	AD-mix- α $((DHQ)_2PHAL)$	95	97	R
AD-mix- β $((DHQD)_2PHAL)$	96	97	S	
4-Methoxy-styrene	AD-mix- α $((DHQ)_2PHAL)$	92	94	R
AD-mix- β $((DHQD)_2PHAL)$	91	93	S	
4-Chloro-styrene	AD-mix- α $((DHQ)_2PHAL)$	88	84	R
AD-mix- β $((DHQD)_2PHAL)$	85	80	S	

Table 2: Enantioselectivity of AD-mix- α vs. AD-mix- β in the Dihydroxylation of trans-Disubstituted and Other Olefins[4]

Substrate	Ligand System	Yield (%)	ee (%)
trans-Stilbene	AD-mix- α ((DHQ) ₂ PHAL)	94	98
AD-mix- β ((DHQD) ₂ PHAL)	96	>99	
1-Decene	AD-mix- α ((DHQ) ₂ PHAL)	90	86
AD-mix- β ((DHQD) ₂ PHAL)	92	91	
Methyl trans-cinnamate	AD-mix- α ((DHQ) ₂ PHAL)	97	94
AD-mix- β ((DHQD) ₂ PHAL)	98	98	

Performance Comparison of Osmium Catalysts in Asymmetric Aminohydroxylation

The Sharpless Asymmetric Aminohydroxylation (AA) allows for the direct, enantioselective synthesis of vicinal amino alcohols from olefins.[5] Similar to the AD reaction, the catalyst system consists of a catalytic amount of an osmium source and a chiral ligand, with a stoichiometric nitrogen source that also acts as the re-oxidant.[6] The choice of chiral ligand and nitrogen source can influence both the yield and the enantioselectivity of the reaction.

Table 3: Enantioselectivity in the Asymmetric Aminohydroxylation of Various Olefins[7][8]

Olefin	Chiral Ligand	Nitrogen Source	Yield (%)	ee (%)
Isopropyl trans-cinnamate	(DHQD) ₂ PHAL	N-Bromoacetamide	92	98
Methyl trans-cinnamate	(DHQD) ₂ PHAL	Chloramine-T	90	99
Styrene	(DHQD) ₂ PHAL	N-Sodio-p-toluenesulfonamide	85	96
1-Octene	(DHQ) ₂ PHAL	N-Bromoacetamide	78	89

Homogeneous vs. Heterogeneous Osmium Catalysts

A significant drawback of traditional osmium-catalyzed reactions is the high toxicity and cost of osmium tetroxide. To address this, considerable effort has been directed towards the development of heterogeneous (immobilized) osmium catalysts.^{[7][8]} These catalysts offer the advantages of easy separation from the reaction mixture, potential for recycling, and reduced osmium contamination in the final product.^[9]

Several strategies have been employed for immobilization, including supporting the osmium catalyst on polymers, silica gel, or layered double hydroxides (LDHs).^{[7][9]} While these heterogeneous catalysts often show comparable enantioselectivities to their homogeneous counterparts, their yields and recyclability can vary depending on the support and the specific substrate.

Table 4: Comparison of Homogeneous and Heterogeneous Osmium Catalysts in the Asymmetric Dihydroxylation of trans-Stilbene^[11]

Catalyst System	Chiral Ligand	Yield (%) (1st Run)	ee (%) (1st Run)	Yield (%) (3rd Run)	ee (%) (3rd Run)
Homogeneous (K ₂ OsO ₂ (OH) ₄)	(DHQD) ₂ PHA L	96	>99	-	-
LDH-OsO ₄	(DHQD) ₂ PHA L	95	99	92	98
Resin-OsO ₄	(DHQD) ₂ PHA L	98	>99	97	>99

Experimental Protocols

General Procedure for Sharpless Asymmetric Dihydroxylation[12]

A mixture of tert-butanol (5 mL) and water (5 mL) is added to a round-bottomed flask containing the AD-mix (1.4 g per 1 mmol of olefin). The mixture is stirred at room temperature until two clear phases are formed. The olefin (1 mmol) is then added, and the reaction mixture is stirred vigorously at room temperature or 0 °C until the reaction is complete (monitored by TLC). Upon completion, solid sodium sulfite (1.5 g) is added, and the mixture is stirred for an additional hour. The product is then extracted with an organic solvent (e.g., ethyl acetate), and the combined organic layers are washed with brine, dried over anhydrous sodium sulfate, and concentrated under reduced pressure. The crude product is purified by flash column chromatography or recrystallization.

Experimental Workflow for Sharpless Asymmetric Dihydroxylation

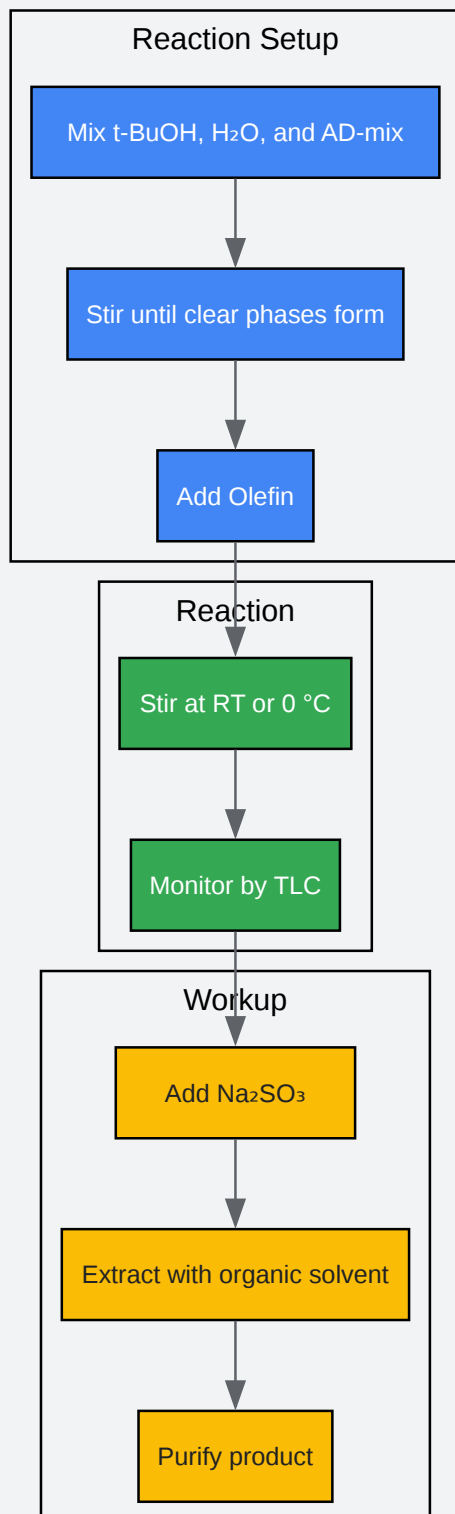

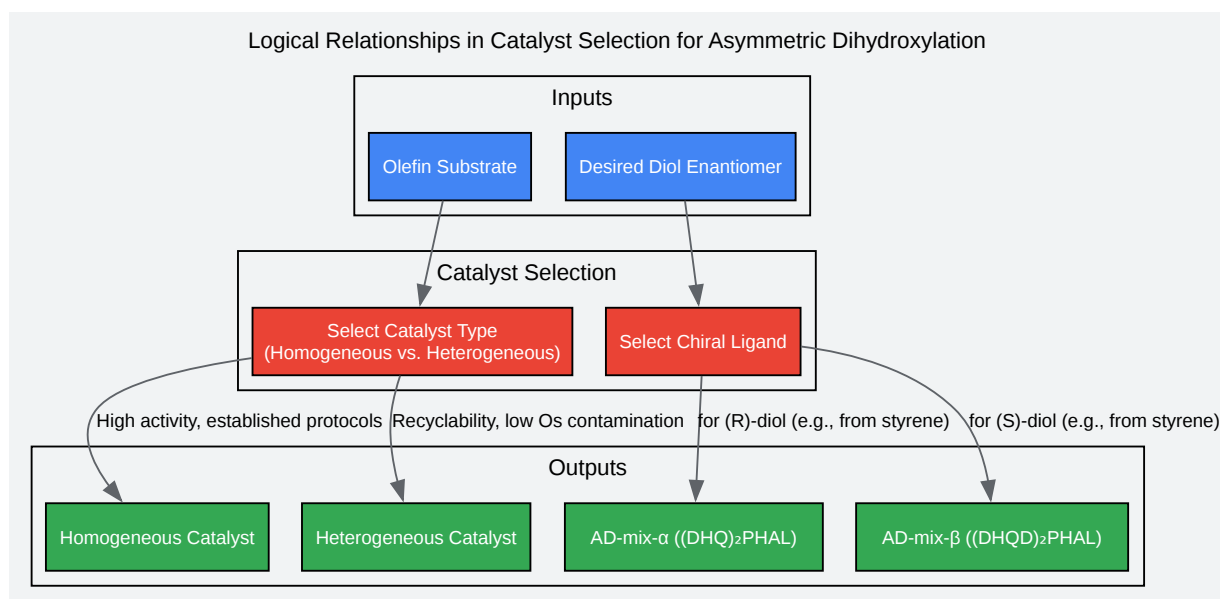

[Click to download full resolution via product page](#)

Need Custom Synthesis?

BenchChem offers custom synthesis for rare earth carbides and specific isotopic labeling.

Email: info@benchchem.com or [Request Quote Online](#).

References

- 1. benchchem.com [benchchem.com]
- 2. Sharpless asymmetric dihydroxylation - Wikipedia [en.wikipedia.org]
- 3. rroj.com [rroj.com]
- 4. benchchem.com [benchchem.com]
- 5. Application of asymmetric Sharpless aminohydroxylation in total synthesis of natural products and some synthetic complex bio-active molecules - PMC [pmc.ncbi.nlm.nih.gov]
- 6. Sharpless Aminohydroxylation (Oxyamination) [organic-chemistry.org]

- 7. researchgate.net [researchgate.net]
- 8. researchgate.net [researchgate.net]
- 9. books.lucp.net [books.lucp.net]
- To cite this document: BenchChem. [A Comparative Guide to the Enantioselectivity of Osmium Catalysts]. BenchChem, [2025]. [Online PDF]. Available at: [https://www.benchchem.com/product/b570676#enantioselectivity-comparison-of-different-osmium-catalysts]

Disclaimer & Data Validity:

The information provided in this document is for Research Use Only (RUO) and is strictly not intended for diagnostic or therapeutic procedures. While BenchChem strives to provide accurate protocols, we make no warranties, express or implied, regarding the fitness of this product for every specific experimental setup.

Technical Support: The protocols provided are for reference purposes. Unsure if this reagent suits your experiment? [[Contact our Ph.D. Support Team for a compatibility check](#)]

Need Industrial/Bulk Grade? [Request Custom Synthesis Quote](#)

BenchChem

Our mission is to be the trusted global source of essential and advanced chemicals, empowering scientists and researchers to drive progress in science and industry.

Contact

Address: 3281 E Guasti Rd

Ontario, CA 91761, United States

Phone: (601) 213-4426

Email: info@benchchem.com