

# Technical Guide: GC-MS Fragmentation & Performance of C H BrF (PFB-Br)

**Author:** BenchChem Technical Support Team. **Date:** May 2026

## Compound of Interest

Compound Name: *6-Bromo-2,3-difluorobenzotrifluoride*

CAS No.: *1242339-23-6*

Cat. No.: *B569885*

[Get Quote](#)

## Executive Summary

C

H

BrF

is not merely an analyte; it is the "gold standard" electrophilic derivatization reagent for the ultra-sensitive detection of acidic moieties (carboxyls, phenols, thiols, sulfonamides) in drug development. While Silylation (BSTFA/TMS) remains the default for general profiling, PFB-Br is the obligatory choice when femtomolar sensitivity is required via Negative Chemical Ionization (NCI).

This guide dissects the mass spectral fingerprint of the reagent itself (for purity verification) and contrasts its performance with silylation alternatives.

## Part 1: The Spectral Fingerprint (Fragmentation Pattern)[1]

Understanding the fragmentation of C

H

BrF

is two-fold: identifying the reagent purity in Electron Ionization (EI) and leveraging its specific dissociation mechanism in Negative Chemical Ionization (NCI).

### Electron Ionization (EI) – The Purity Check

In standard 70 eV EI mode, C

H

BrF

exhibits a distinct, "hard" fragmentation pattern driven by the labile C-Br bond.

- Molecular Ion (M

): Weak intensity at  $m/z$  260 (

Br) and  $m/z$  262 (

Br). The 1:1 isotopic ratio confirms the presence of one bromine atom.

- Base Peak ( $m/z$  181): The spectrum is dominated by the pentafluorobenzyl cation [C

F

CH

]

. This ion is formed by the heterolytic cleavage of the C-Br bond. It is the diagnostic "fingerprint" ion for this reagent.

- Secondary Fragments:

- o m/z 161: [C

H

F

]

(Loss of F from the tropylium-like core).

- o m/z 155: [C

F

]

(Ring contraction/fragmentation).

## EI Fragmentation Pathway (Graphviz)

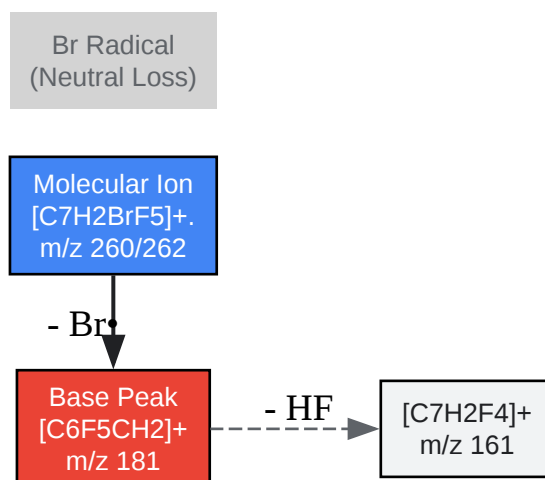

[Click to download full resolution via product page](#)

Figure 1: EI Fragmentation pathway of PFB-Br showing the dominance of the pentafluorobenzyl cation (m/z 181).

## Negative Chemical Ionization (NCI) – The Performance Engine

In NCI (using Methane or Ammonia as reagent gas), C

H

BrF

behaves differently. It acts as an electron capture agent.<sup>[1][2]</sup>

- Mechanism: Dissociative Electron Capture (DEC).
- Reagent Ions: If injected pure, the spectrum is dominated by Br (m/z 79/81).
- Background Artifacts: You will often observe m/z 167 ([C

F

]

) and m/z 196 (likely [C

F

CHO]

), which are degradation products or impurities formed in the source.

## Part 2: Comparative Performance (PFB-Br vs. Alternatives)

For drug development professionals, the choice between PFB-Br and Silylation (e.g., BSTFA/TMS) determines the limit of detection (LOD).

### Performance Matrix

Feature	PFB-Br (Alkylation)	BSTFA/TMS (Silylation)	Scientific Rationale
Primary Ionization	NCI (Negative Chemical Ionization)	EI (Electron Ionization)	PFB moiety has high electron affinity ( ), acting as an "electron magnet."
Sensitivity (LOD)	Attomole ( )	Picomole ( )	NCI background is near-zero; EI background is high. PFB-Br is more sensitive for acidic drugs.
Selectivity	High (Specific to acidic protons)	Low (Reacts with all active H)	PFB-Br targets -COOH/-OH/-SH specifically; TMS covers everything, increasing noise.
Spectral Stability	High (Stable covalent bond)	Low (Hydrolytically unstable)	TMS esters revert to acids upon moisture exposure; PFB esters are robust.
Diagnostic Ion	[M-PFB] (Carboxylate anion)	[M-15] or [M-TMS]	PFB derivatives lose the tag to reveal the intact drug anion ( ).

## Decision Logic for Researchers

Use PFB-Br if:

- Target analyte concentration is < 10 ng/mL (trace analysis).
- Matrix is complex (plasma/urine) and requires high selectivity.

- Analyte has a carboxylic acid or phenolic group.<sup>[2][3]</sup>

Use BSTFA if:

- General unknown screening is required (library matching with NIST).
- Analyte is an alcohol or amine without acidic functions.
- Concentration is high (> 1 µg/mL).

## Part 3: Experimental Protocol (Self-Validating)

This protocol describes the derivatization of a generic acidic drug metabolite (R-COOH) using PFB-Br.

### Reagents

- Reagent A: 5% C

H

BrF

in anhydrous acetonitrile.

- Base: Diisopropylethylamine (DIEA) or finely powdered K

CO

.

- Solvent: Hexane (for extraction).<sup>[4]</sup>

### Step-by-Step Workflow

- Preparation: Dissolve dry residue of the biological extract in 50 µL acetonitrile.
- Catalysis: Add 10 µL of Base (DIEA). Rationale: Neutralizes the acid to form the carboxylate nucleophile.
- Alkylation: Add 20 µL of Reagent A. Cap and heat at 60°C for 30 mins.

- Mechanism:[5] S
  - 2 nucleophilic attack of R-COO
  - on the benzylic carbon of PFB-Br.
- Cleanup (CRITICAL): Evaporate to dryness under N
  - or react excess PFB-Br with an amine.
- Why? Excess PFB-Br enters the source and depletes the electron population, suppressing the signal of your analyte.
- Reconstitution: Dissolve in 100  $\mu$ L Hexane.
- Validation Check: Inject 1  $\mu$ L into GC-MS (NCI Mode).
  - Pass Criteria: Presence of [M-181]  
ion (Analyte anion).
  - Fail Criteria: Dominant m/z 79/81 peaks (indicates insufficient cleanup of reagent).

## Derivatization Pathway Diagram

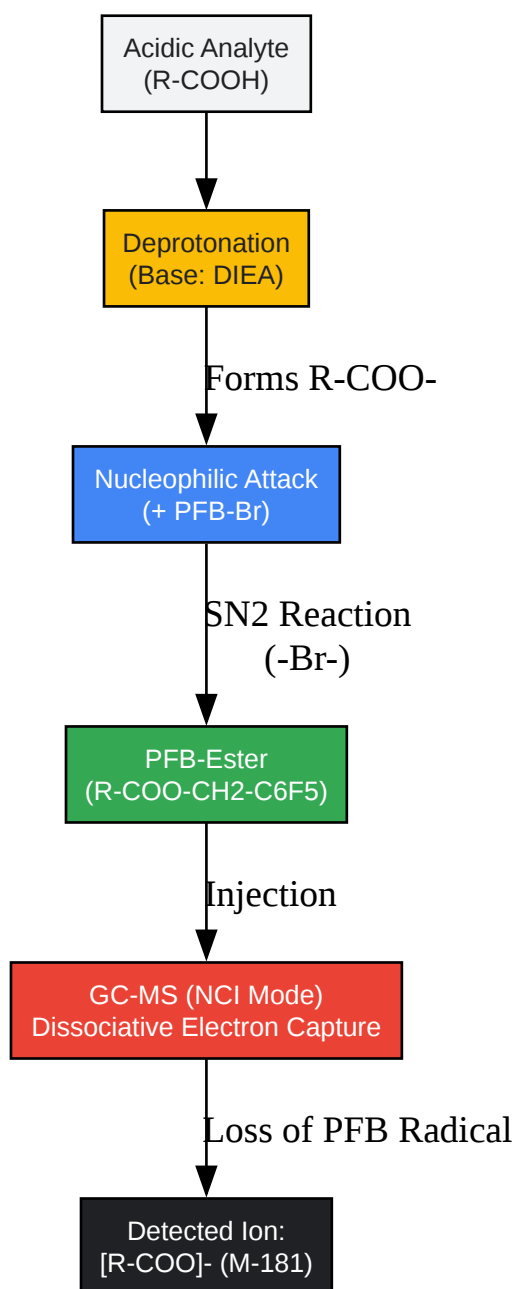

[Click to download full resolution via product page](#)

Figure 2: Reaction and detection workflow for PFB-Br derivatization in NCI-GC-MS.

## References

- National Institute of Standards and Technology (NIST). (2023).[6] Mass Spectrum of Pentafluorobenzyl Bromide (m/z 181). NIST Chemistry WebBook, SRD 69. [\[Link\]](#)

- Tsikas, D. (2025). Pentafluorobenzyl bromide - A versatile derivatization agent in chromatography and mass spectrometry: II. Analysis of organic acids and bases. Journal of Chromatography B. [[Link](#)]
- Wu, H., et al. (2020). Comparison of MTBSTFA and BSTFA in derivatization reactions of polar compounds prior to GC/MS analysis. ResearchGate. [[Link](#)]

### Need Custom Synthesis?

BenchChem offers custom synthesis for rare earth carbides and specific isotopic labeling.

Email: [info@benchchem.com](mailto:info@benchchem.com) or [Request Quote Online](#).

## Sources

- 1. [α-Bromo-2,3,4,5,6-pentafluorotoluene | 1765-40-8 \[chemicalbook.com\]](#)
- 2. [pentafluorobenzyl bromide derivatization: Topics by Science.gov \[science.gov\]](#)
- 3. [chem.libretexts.org \[chem.libretexts.org\]](#)
- 4. [Comparison of methods for extraction, storage, and silylation of pentafluorobenzyl derivatives of carbonyl compounds and multi-functional carbonyl compounds - PubMed \[pubmed.ncbi.nlm.nih.gov\]](#)
- 5. [echemi.com \[echemi.com\]](#)
- 6. [Pentafluorobenzyl bromide | C7H2BrF5 | CID 74484 - PubChem \[pubchem.ncbi.nlm.nih.gov\]](#)
- To cite this document: BenchChem. [Technical Guide: GC-MS Fragmentation & Performance of C H BrF (PFB-Br)]. BenchChem, [2026]. [Online PDF]. Available at: [<https://www.benchchem.com/product/b569885/docs#technical-guide-gc-ms-fragmentation-performance-of-c-h-brf-pfb-br>]

---

### Disclaimer & Data Validity:

The information provided in this document is for Research Use Only (RUO) and is strictly not intended for diagnostic or therapeutic procedures. While BenchChem strives to provide accurate protocols, we make no warranties, express or implied, regarding the fitness of this product for every specific experimental setup.

**Technical Support:** The protocols provided are for reference purposes. Unsure if this reagent suits your experiment?

**Need Industrial/Bulk Grade?** [Request Custom Synthesis Quote](#)

## BenchChem

Our mission is to be the trusted global source of essential and advanced chemicals, empowering scientists and researchers to drive progress in science and industry.

### Contact

Address: 3281 E Guasti Rd  
Ontario, CA 91761, United States  
Phone: (601) 213-4426  
Email: [info@benchchem.com](mailto:info@benchchem.com)

[Contact our Ph.D. Support Team for a compatibility check](#)