

Precision Quantification of 14S-HDHA via Chiral LC-MS/MS

Author: BenchChem Technical Support Team. **Date:** May 2026

Compound of Interest

Compound Name: 14S-Hdha
CAS No.: 119433-37-3
Cat. No.: B569566

[Get Quote](#)

Application Note & Protocol Guide

Abstract

This application note details a high-sensitivity, stereoselective Liquid Chromatography-Tandem Mass Spectrometry (LC-MS/MS) protocol for the quantification of 14(S)-hydroxy-docosahexaenoic acid (**14S-HDHA**) in biological matrices. **14S-HDHA** is a bioactive lipid mediator and a stable pathway marker for the biosynthesis of Maresins (Macrophage Mediator in Resolving Inflammation). Unlike standard lipidomics workflows that utilize achiral C18 chromatography, this protocol emphasizes chiral separation to distinguish the enzymatic 14S-isomer (12-LOX derived) from the non-enzymatic 14R-isomer (autoxidation derived), ensuring data integrity in inflammation and resolution studies.

Introduction & Biological Context

The resolution of inflammation is an active process governed by Specialized Pro-resolving Mediators (SPMs). Docosahexaenoic acid (DHA) is converted by 12-Lipoxygenase (12-LOX) into 14S-hydroperoxy-DHA (14S-HpDHA), which is rapidly reduced to **14S-HDHA** or further metabolized into Maresin 1 (MaR1) via the 13S,14S-epoxide intermediate.^{[1][2][3][4]}

While **14S-HDHA** possesses its own anti-inflammatory properties, its accurate quantification is critical primarily as a stable surrogate for 12-LOX activity and Maresin pathway flux.

The Isomer Challenge: Biological samples often contain a mixture of enantiomers.

- 14(S)-HDHA: Enzymatic product (Anti-inflammatory/Pro-resolving).[5]
- 14(R)-HDHA: Product of free-radical autoxidation or cytochrome P450 activity.
- Achiral Analysis (C18): Co-elutes both isomers, leading to overestimation of enzymatic pathway activity.
- Chiral Analysis: Separates R and S forms, providing a true measure of biological orchestration.

Biosynthetic Pathway of 14S-HDHA and Maresins[1][3][6]

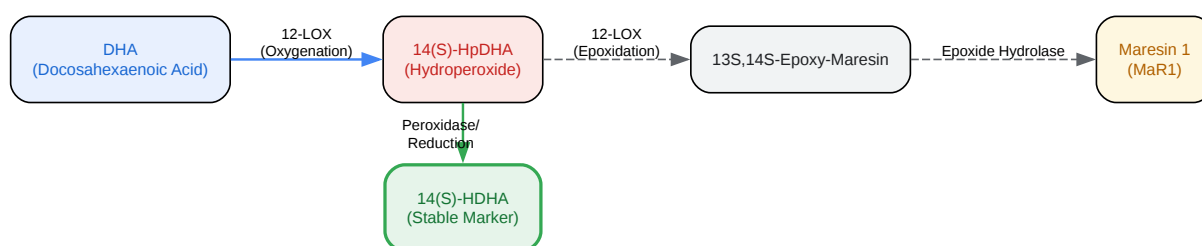

[Click to download full resolution via product page](#)

Figure 1: Biosynthetic route of **14S-HDHA** from DHA via 12-Lipoxygenase. **14S-HDHA** serves as the stable reduced marker of the transient hydroperoxide intermediate.

Experimental Design Strategy

3.1 Internal Standards (The Pillar of Accuracy)

Quantification in lipidomics is prone to matrix effects (ion suppression). You must use a deuterated internal standard (IS) added prior to extraction.

- Primary Choice: 14(S)-HDHA-d5 (if commercially available).

- Alternative: DHA-d5 or 12(S)-HETE-d8.
- Rationale: The IS corrects for extraction loss and ionization variability.

3.2 Sample Preparation: Solid Phase Extraction (SPE)

Liquid-Liquid Extraction (LLE) is common but often yields "dirty" extracts with high phospholipid background that contaminates the MS source. SPE is preferred for targeted SPM analysis to enrich fatty acid metabolites and remove neutral lipids and proteins.

3.3 Chromatography: Chiral vs. Achiral[7]

- Protocol A (Screening): Reverse Phase C18. Fast, robust, but cannot distinguish S/R isomers.
- Protocol B (Validation - Recommended): Chiral Stationary Phase (e.g., Chiralpak AD-RH). Essential for proving the enzymatic origin of the metabolite.

Protocol 1: Sample Preparation (Solid Phase Extraction)

Reagents:

- Methanol (MeOH), Acetonitrile (ACN), Water (LC-MS grade).[8]
- Formic Acid or Acetic Acid.
- Methyl formate.
- Internal Standard Solution (1 ng/μL in MeOH).
- SPE Cartridges: C18 (e.g., 200mg/3mL) or Polymeric Reversed-Phase (e.g., Oasis HLB).

Step-by-Step Workflow:

- Sample Thawing: Thaw plasma/tissue homogenates on ice. Work quickly to prevent ex vivo oxidation.
- Protein Precipitation:

- Aliquot 200-500 μ L of sample.
- Add cold methanol (3x sample volume) containing the Internal Standard (e.g., 1 ng of d5-14-HDHA).
- Why: Denatures proteins and releases lipids bound to albumin.
- Centrifugation: Spin at 10,000 x g for 10 min at 4°C. Collect supernatant.
- Dilution: Dilute supernatant with acidified water (pH 3.5, using dilute HCl or Acetic Acid) to reduce organic content to <15% MeOH.
 - Why: High organic content will cause lipids to break through the SPE column during loading.
- SPE Conditioning:
 - Wash cartridge with 3 mL MeOH.
 - Equilibrate with 3 mL Water (pH 3.5).
- Loading: Load the diluted sample onto the cartridge by gravity or low vacuum.
- Washing: Wash with 3 mL Water/MeOH (90:10) to remove salts and polar interferences.
- Elution: Elute **14S-HDHA** with 3 mL Methyl Formate or Methanol.
 - Note: Methyl formate is excellent for PUFA metabolites and evaporates quickly.
- Drying: Evaporate eluate to dryness under a gentle stream of Nitrogen (N₂).
- Reconstitution: Dissolve residue in 100 μ L of Mobile Phase (50:50 Water/MeOH).

Protocol 2: LC-MS/MS Method Parameters[9]

5.1 Chromatographic Conditions (Chiral Method)

To ensure the analyte is 14S-HDHA and not the 14R isomer.

- System: UHPLC (e.g., Agilent 1290, Shimadzu Nexera, Waters Acquity).

- Column: Chiralpak AD-RH (150 x 2.1 mm, 5 μ m) or equivalent amylose-based reverse-phase chiral column.
- Column Temp: 25°C (Lower temperature often improves chiral resolution).
- Flow Rate: 0.2 mL/min.
- Mobile Phase A: Water + 0.1% Acetic Acid.
- Mobile Phase B: Acetonitrile/Methanol (50:50) + 0.1% Acetic Acid.
- Gradient:
 - 0-1 min: 40% B
 - 1-15 min: Linear gradient to 95% B
 - 15-18 min: Hold at 95% B
 - 18.1 min: Re-equilibrate at 40% B.

5.2 Mass Spectrometry Parameters

- Ionization: Electrospray Ionization (ESI), Negative Mode (-).[9]
- Detection: Multiple Reaction Monitoring (MRM).[10][11]
- Source Temp: 350°C.
- Capillary Voltage: -3500 V.

MRM Transition Table:

Analyte	Precursor Ion (m/z)	Product Ion (m/z)	Dwell (ms)	Collision Energy (V)	Role
14(S)-HDHA	343.2	205.2	50	18-22	Quantifier
14(S)-HDHA	343.2	221.2	50	16-20	Qualifier
14(S)-HDHA	343.2	59.0	50	30	Qualifier (Acetate)
IS (d5-DHA)	332.3	288.3	50	15	Internal Std

Note: The transition 343 -> 205 corresponds to cleavage adjacent to the hydroxyl group at C14, highly specific for 14-HDHA.

Analytical Workflow Diagram

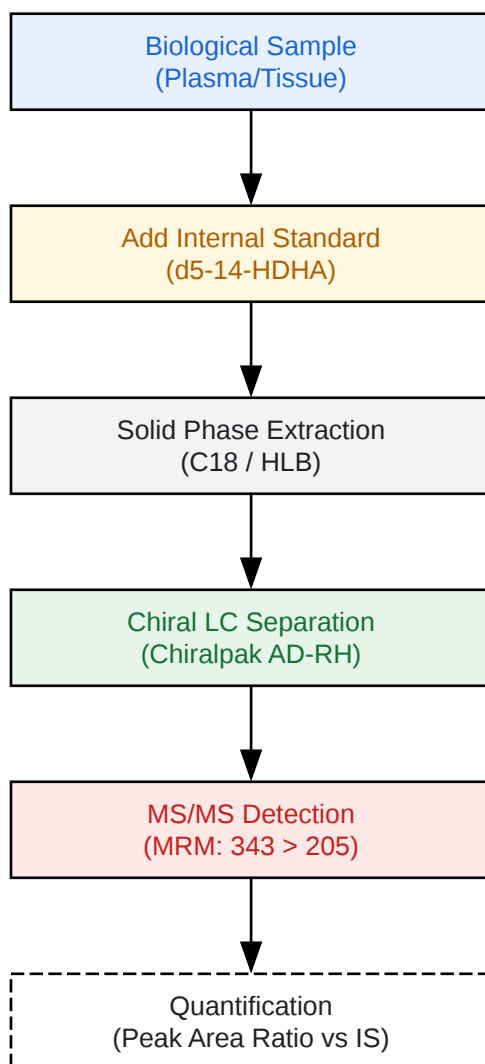

[Click to download full resolution via product page](#)

Figure 2: Step-by-step analytical workflow for **14S-HDHA** quantification.

Validation & Quality Control (Self-Validating System)

To ensure Trustworthiness (Part 2 of Core Requirements), the method must be validated:

- Linearity: Construct a calibration curve (e.g., 0.1 ng/mL to 100 ng/mL) using synthetic **14S-HDHA** standards spiked into PBS or stripped plasma. R^2 should be > 0.99 .
- Recovery: Compare the peak area of IS added before extraction vs. IS added after extraction. Recovery should be $> 70\%$.

- Chiral Resolution: Inject a racemic mixture of 14(R/S)-HDHA. Ensure baseline separation (Resolution > 1.5) between the R and S peaks. If they co-elute, the method is invalid for specific enzymatic profiling.
- Carryover: Inject a solvent blank after the highest standard. Peak area in blank should be < 20% of the LLOQ (Lower Limit of Quantification).

Data Analysis

Calculate the concentration of **14S-HDHA** using the Isotope Dilution Method:

- : Concentration of **14S-HDHA**[1][3][5]
- : Concentration of Internal Standard
- : Response Factor (derived from calibration curve slope)

References

- Dalli, J., et al. (2013). The novel 13S,14S-epoxy-maresin is converted by human macrophages to maresin 1 (MaR1), inhibits leukotriene A4 hydrolase (LTA4H), and shifts macrophage phenotype. FASEB Journal.
- Serhan, C. N., et al. (2009). Maresins: novel macrophage mediators with potent antiinflammatory and proresolving actions.[12] Journal of Experimental Medicine.
- Gladine, C., et al. (2014). Lipid mediator profiling of inflammatory resolution in human adipose tissue. Journal of Chromatography B.
- Masoodi, M., et al. (2012). Comprehensive lipidomics analysis of bioactive lipids in complex biological matrices. Analytical Chemistry.[13][11][14][15]
- Yang, R., et al. (2013). LC-MS/MS-based chiral profiling of DHA-derived specialized pro-resolving mediators.[5] Metabolomics.[10][12][16]

Need Custom Synthesis?

BenchChem offers custom synthesis for rare earth carbides and specific isotopic labeling.

Email: info@benchchem.com or [Request Quote Online](#).

Sources

- 1. Biosynthesis of the Maresin Intermediate, 13S,14S-Epoxy-DHA, by Human 15-Lipoxygenase and 12-Lipoxygenase and Its Regulation through Negative Allosteric Modulators - PubMed [pubmed.ncbi.nlm.nih.gov]
- 2. The Development of a Specific and Sensitive LC-MS-Based Method for the Detection and Quantification of Hydroperoxy- and Hydroxydocosaehaenoic Acids as a Tool for Lipidomic Analysis - PMC [pmc.ncbi.nlm.nih.gov]
- 3. pnas.org [pnas.org]
- 4. The novel 13S,14S-epoxy-maresin is converted by human macrophages to maresin 1 (MaR1), inhibits leukotriene A4 hydrolase (LTA4H), and shifts macrophage phenotype - PMC [pmc.ncbi.nlm.nih.gov]
- 5. researchgate.net [researchgate.net]
- 6. mdpi.com [mdpi.com]
- 7. Deducing formation routes of oxylipins by quantitative multiple heart-cutting achiral-chiral 2D-LC-MS - PMC [pmc.ncbi.nlm.nih.gov]
- 8. Chiral lipidomics of monoepoxy and monohydroxy metabolites derived from long-chain polyunsaturated fatty acids - PMC [pmc.ncbi.nlm.nih.gov]
- 9. Targeted Metabolomic Profiling of Total Fatty Acids in Human Plasma by Liquid Chromatography-Tandem Mass Spectrometry - PMC [pmc.ncbi.nlm.nih.gov]
- 10. LC-MS/MS-MRM-Based Targeted Metabolomics for Quantitative Analysis of Polyunsaturated Fatty Acids and Oxylipins | Springer Nature Experiments [experiments.springernature.com]
- 11. lcms.cz [lcms.cz]
- 12. Maresin Biosynthesis and Identification of Maresin 2, a New Anti-Inflammatory and Pro-Resolving Mediator from Human Macrophages | PLOS One [journals.plos.org]
- 13. jsbms.jp [jsbms.jp]
- 14. agilent.com [agilent.com]
- 15. mdpi.com [mdpi.com]
- 16. A Novel Solid Phase Extraction Sample Preparation Method for Lipidomic Analysis of Human Plasma Using Liquid Chromatography/Mass Spectrometry - PubMed [pubmed.ncbi.nlm.nih.gov]

- To cite this document: BenchChem. [Precision Quantification of 14S-HDHA via Chiral LC-MS/MS]. BenchChem, [2026]. [Online PDF]. Available at: [<https://www.benchchem.com/product/b569566/docs#precision-quantification-of-14s-hdha-via-chiral-lc-ms-ms>]

Disclaimer & Data Validity:

The information provided in this document is for Research Use Only (RUO) and is strictly not intended for diagnostic or therapeutic procedures. While BenchChem strives to provide accurate protocols, we make no warranties, express or implied, regarding the fitness of this product for every specific experimental setup.

Technical Support: The protocols provided are for reference purposes. Unsure if this reagent suits your experiment?

Need Industrial/Bulk Grade? [Request Custom Synthesis Quote](#)

BenchChem

Our mission is to be the trusted global source of essential and advanced chemicals, empowering scientists and researchers to drive progress in science and industry.

Contact

Address: 3281 E Guasti Rd

Ontario, CA 91761, United States

Phone: (601) 213-4426

Email: info@benchchem.com

[Contact our Ph.D. Support Team for a compatibility check](#)