

Application Note: Investigating 14S-Hdha Function in Inflammation Resolution

Author: BenchChem Technical Support Team. **Date:** May 2026

Compound of Interest

Compound Name:	14S-Hdha
CAS No.:	119433-37-3
Cat. No.:	B569566

[Get Quote](#)

Subtitle: Advanced Protocols for Animal Models, Lipidomic Profiling, and Pathway Analysis

Executive Summary

The resolution of inflammation is an active, biochemically regulated process driven by Specialized Pro-resolving Mediators (SPMs).^{[1][2][3][4]} **14S-Hdha** is a critical bioactive marker and the immediate biosynthetic precursor to the Maresin family (Macrophage Mediator in Resolving Inflammation), specifically Maresin 1 (MaR1).^[3]

Understanding the function of **14S-Hdha** requires a dual approach:

- Genetic/Functional Models: Utilizing Alox15 deficient mice to isolate the enzymatic source.
- Analytical Precision: Distinguishing the enzymatic 14S-stereoisomer from the auto-oxidative 14R-isomer using chiral LC-MS/MS.

This guide provides a validated framework for studying **14S-Hdha** in murine models of inflammation, focusing on the "Gold Standard" Zymosan-induced peritonitis model.

The Biological Context: The Maresin Pathway

14S-Hdha is not merely a passive intermediate; it possesses intrinsic bioactivity (e.g., inhibiting platelet aggregation) and serves as the obligate precursor for tissue-regenerative Maresins.

Mechanism of Action

In murine systems, 12/15-Lipoxygenase (Alox15) oxygenates Docosahexaenoic Acid (DHA) at the carbon-14 position. This produces 14S-hydroperoxy-DHA (14S-HpDHA), which is rapidly reduced to **14S-Hdha** or epoxidized to 13S,14S-epoxy-maresin, the precursor to MaR1.[5]

Expert Insight: While human 12-LOX is the primary enzyme for this pathway in humans, the murine ortholog Alox15 (12/15-LOX) performs this function in mice. Therefore, Alox15 knockout mice are the definitive negative control for **14S-Hdha** studies.

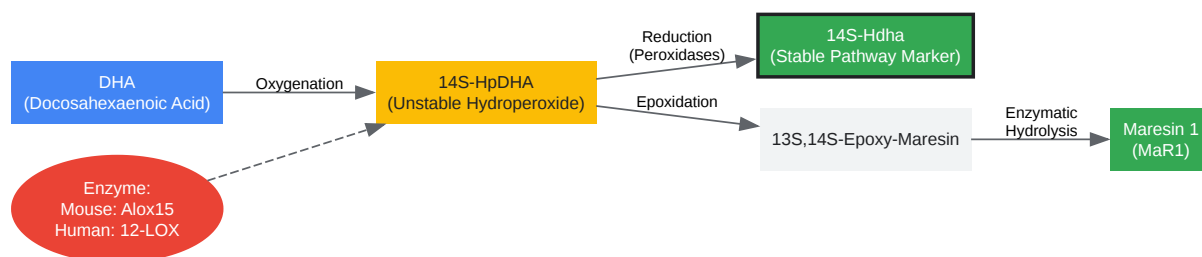

[Click to download full resolution via product page](#)

Figure 1: The biosynthetic hierarchy of the Maresin pathway. **14S-Hdha** serves as the stable bioactive marker for pathway activation.

Animal Model Selection

To rigorously study **14S-Hdha**, researchers must select models that challenge the resolution phase of inflammation.

Model Type	Strain/Agent	Rationale	Key Readout for 14S-Hdha
Loss of Function	Alox15 ^{-/-} (C57BL/6 background)	Removes the primary enzyme responsible for 14S-oxygenation of DHA in mice.	Absent/Low 14S-Hdha levels despite inflammation; delayed resolution.
Resolution Challenge	Zymosan A Peritonitis	Self-resolving acute inflammation. Distinct onset (PMN influx) and resolution (Macrophage cleanup) phases.	Peak 14S-Hdha occurs during the resolution phase (12h–24h post-challenge).
Tissue Injury	Ischemia-Reperfusion (I/R)	Mimics stroke or MI; induces massive lipid mediator storms.	14S-Hdha correlates with tissue protection and reduced infarct size.
Dietary Gain of Function	DHA Enrichment	Feeding 1-3% DHA diet for 4 weeks prior to injury.	Substrate loading increases basal and stimulated 14S-Hdha.

Experimental Protocol: Zymosan-Induced Peritonitis

This protocol is designed to maximize the detection of resolution-phase lipid mediators like **14S-Hdha**.

Phase 1: Induction (In Vivo)

- Animals: Male C57BL/6 mice (or Alox15 ^{-/-}), 8-10 weeks old.
- Reagent: Zymosan A (Sigma), prepared at 1 mg/mL in sterile saline. Note: Sonicate mildly to ensure homogenous suspension.
- Dosage: 1 mg per mouse (1 mL i.p. injection).
- Timepoints:

- 0h: Baseline.
- 4h: Peak Inflammation (Maximal Neutrophil infiltration).
- 12h - 24h: Resolution Phase (Critical Window for **14S-Hdha**/Maresins).

Phase 2: Exudate Collection (Ex Vivo)

- Euthanasia: Isoflurane overdose or CO₂ asphyxiation.
- Lavage: Inject 3 mL of cold PBS (with calcium/magnesium free) into the peritoneum. Massage abdomen gently for 30 seconds.
- Recovery: Aspirate fluid.
- Immediate Stabilization (CRITICAL):
 - Add 2 volumes of ice-cold Methanol immediately to the lavage fluid.
 - Why? This denatures proteins and stops enzymatic degradation or further oxidation of lipids.
 - Add Internal Standard: d5-**14S-HDHA** (500 pg) to correct for extraction losses.

Phase 3: Lipid Extraction (Solid Phase Extraction - SPE)

- Cartridge: C18 SPE columns (e.g., Waters Sep-Pak tC18).
- Conditioning: Wash with 1 volume Methanol, then 1 volume Water (pH 3.5).
- Loading: Acidify sample to pH 3.5 (using HCl) and load onto column.
- Wash: Wash with water (neutralize acid) and Hexane (remove non-polar fats).
- Elution: Elute SPM fraction with Methyl Formate.
- Drying: Evaporate solvent under a gentle stream of Nitrogen gas. Resuspend in Methanol/Water (50:50) for LC-MS.

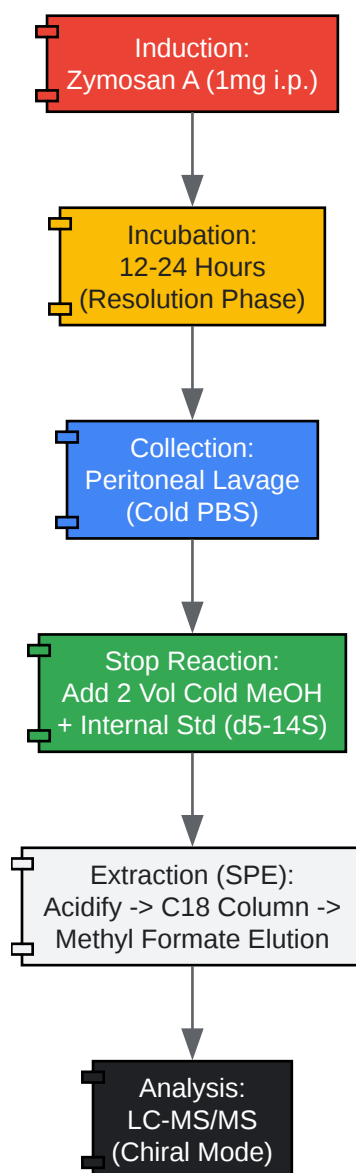

[Click to download full resolution via product page](#)

Figure 2: Step-by-step workflow for isolating **14S-Hdha** from murine peritonitis exudates.

Analytical Validation: LC-MS/MS Targeted Profiling

The validity of **14S-Hdha** data hinges on separating it from its auto-oxidation isomer (14R-Hdha). Standard Reverse Phase (RP) chromatography cannot distinguish these.

Protocol Parameters

- Instrument: Triple Quadrupole MS (e.g., Sciex 6500+ or equivalent).

- Ionization: Electrospray Ionization (ESI) Negative Mode.
- Chiral Column (Mandatory): Chiralpak AD-H or equivalent (Amylose tris-3,5-dimethylphenylcarbamate).
- Mobile Phase: Hexane/Methanol/Ethanol gradients (Normal Phase Chiral) or specialized Reverse Phase Chiral methods.

MRM Transitions (Multiple Reaction Monitoring)

Analyte	Precursor Ion (Q1) m/z	Product Ion (Q3) m/z	Retention Time (Approx)
14S-Hdha	343.2	205.1	Distinct from 14R
14R-Hdha	343.2	205.1	Distinct from 14S
d5-14S-Hdha (IS)	348.2	210.1	Co-elutes with 14S
MaR1	359.2	250.1	Downstream metabolite

Data Interpretation:

- Enzymatic Source: A sharp, dominant peak at the 14S retention time indicates LOX activity.
- Oxidative Stress: Two equal peaks (racemic mixture) of 14S and 14R indicate non-enzymatic auto-oxidation (random attack by ROS).

References

- Serhan, C. N., et al. (2009).^{[3][6]} Maresins: novel macrophage mediators with potent antiinflammatory and proresolving actions.^[4] The Journal of Experimental Medicine.
- Dalli, J., et al. (2013).^[3] The novel 13S,14S-epoxy-maresin is converted by human macrophages to maresin 1 (MaR1), inhibits leukotriene A4 hydrolase (LTA4H), and shifts macrophage phenotype.^[3] FASEB Journal.
- Deng, B., et al. (2014). Maresin biosynthesis and identification of maresin 2, a new anti-inflammatory and pro-resolving mediator from human macrophages. PLOS ONE.

- Arita, M., et al. (2005). Stereochemical assignment, antiinflammatory properties, and receptor interaction of the new 10,17-docosatriene (neuroprotectin D1). *Journal of Experimental Medicine*.
- Reisch, F., et al. (2023).[7][8] Knock-in mice expressing a humanized arachidonic acid 15-lipoxygenase (Alox15) carry a partly dysfunctional erythropoietic system.[7] *Cellular & Molecular Biology Letters*.[7]

Need Custom Synthesis?

BenchChem offers custom synthesis for rare earth carbides and specific isotopic labeling.

Email: info@benchchem.com or [Request Quote Online](#).

Sources

- [1. mdpi.com \[mdpi.com\]](https://www.mdpi.com)
- [2. Potential Clinical Applications of Pro-Resolving Lipids Mediators from Docosahexaenoic Acid - PMC \[pmc.ncbi.nlm.nih.gov\]](https://pubmed.ncbi.nlm.nih.gov/)
- [3. DHA- and EPA-derived resolvins, protectins, and maresins in airway inflammation - PMC \[pmc.ncbi.nlm.nih.gov\]](https://pubmed.ncbi.nlm.nih.gov/)
- [4. researchgate.net \[researchgate.net\]](https://www.researchgate.net)
- [5. Maresin Biosynthesis and Identification of Maresin 2, a New Anti-Inflammatory and Pro-Resolving Mediator from Human Macrophages | PLOS One \[journals.plos.org\]](https://doi.org/10.1371/journal.plosone.0171111)
- [6. Frontiers | Novel lipid mediator 7S,14R-docosahexaenoic acid: biogenesis and harnessing mesenchymal stem cells to ameliorate diabetic mellitus and retinal pericyte loss \[frontiersin.org\]](https://doi.org/10.3389/fnins.2017.00111)
- [7. researchgate.net \[researchgate.net\]](https://www.researchgate.net)
- [8. Knock-in mice expressing a humanized arachidonic acid 15-lipoxygenase \(Alox15\) carry a partly dysfunctional erythropoietic system - PMC \[pmc.ncbi.nlm.nih.gov\]](https://pubmed.ncbi.nlm.nih.gov/)
- To cite this document: BenchChem. [Application Note: Investigating 14S-Hdha Function in Inflammation Resolution]. BenchChem, [2026]. [Online PDF]. Available at: [\[https://www.benchchem.com/product/b569566/docs#application-note-investigating-14s-hdha-function-in-inflammation-resolution\]](https://www.benchchem.com/product/b569566/docs#application-note-investigating-14s-hdha-function-in-inflammation-resolution)

Disclaimer & Data Validity:

The information provided in this document is for Research Use Only (RUO) and is strictly not intended for diagnostic or therapeutic procedures. While BenchChem strives to provide accurate protocols, we make no warranties, express or implied, regarding the fitness of this product for every specific experimental setup.

Technical Support: The protocols provided are for reference purposes. Unsure if this reagent suits your experiment?

Need Industrial/Bulk Grade? [Request Custom Synthesis Quote](#)

BenchChem

Our mission is to be the trusted global source of essential and advanced chemicals, empowering scientists and researchers to drive progress in science and industry.

Contact

Address: 3281 E Guasti Rd
Ontario, CA 91761, United States
Phone: (601) 213-4426
Email: info@benchchem.com

[Contact our Ph.D. Support Team for a compatibility check](#)