

6-Bromotriazolo[1,5-a]pyrazine: A Comprehensive Technical Guide for Researchers

Author: BenchChem Technical Support Team. **Date:** December 2025

Compound of Interest

Compound Name: 6-Bromo[1,2,4]triazolo[1,5-a]pyrazine

Cat. No.: B567526

[Get Quote](#)

For Immediate Release

This technical guide provides an in-depth overview of the chemical properties, synthesis, and potential applications of 6-Bromotriazolo[1,5-a]pyrazine, a key intermediate in medicinal chemistry. This document is intended for researchers, scientists, and drug development professionals interested in the utility of this versatile heterocyclic compound.

Core Chemical Properties

6-Bromotriazolo[1,5-a]pyrazine is a yellowish solid at room temperature.^[1] It is a valuable building block in the synthesis of various biologically active molecules, particularly kinase inhibitors.^[1] The presence of the bromine atom at the 6-position allows for facile derivatization through cross-coupling reactions, making it a versatile scaffold for creating diverse chemical libraries.^[1]

Quantitative Data Summary

Property	Value	Source
CAS Number	1233026-51-1	[1]
Molecular Formula	C ₅ H ₃ BrN ₄	[2]
Molecular Weight	199.01 g/mol	[1]
Appearance	Yellowish solid	[1]
Solubility	Poor in water; Soluble in DMSO and DMF	[1]
Thermal Stability	Decomposition starts at 220 °C	[1]
Storage	Sensitive to light; Store at 2-8 °C in an amber vial	[1]

Experimental Protocols

Detailed experimental protocols are crucial for the successful application of 6-Bromotriazolo[1,5-a]pyrazine in research and development. The following sections provide generalized procedures for its synthesis, purification, and a key synthetic application.

Synthesis of 6-Bromotriazolo[1,5-a]pyrazine

While a specific detailed protocol for 6-Bromotriazolo[1,5-a]pyrazine was not found in the public domain, a general synthesis for a related compound, 6-bromo-2-methyl[1][3][4]triazolo[1,5-a]pyridine, can be adapted. This synthesis involves the cyclization of a substituted aminopyridine precursor.

General Procedure (Adapted):

- A solution of the appropriate aminopyrazine precursor is prepared in a suitable solvent (e.g., ethanol).
- A cyclizing agent is added, and the reaction mixture is heated under reflux for a specified period.

- Upon completion, the reaction is cooled, and the solvent is removed under reduced pressure.
- The crude product is then purified as described in the following section.

Purification Protocol

Purification of the crude 6-Bromotriazolo[1,5-a]pyrazine is essential to remove unreacted starting materials and byproducts.

Recrystallization:

- Dissolve the crude solid in a minimal amount of a hot solvent in which the compound has high solubility (e.g., ethanol or a mixture of chloroform and hexane).
- Allow the solution to cool slowly to room temperature, then cool further in an ice bath to promote crystallization.
- Collect the crystals by filtration, wash with a small amount of cold solvent, and dry under vacuum.

Column Chromatography:

- Prepare a silica gel column using an appropriate eluent system (e.g., a mixture of hexane and ethyl acetate).
- Dissolve the crude product in a minimal amount of the eluent and load it onto the column.
- Elute the column with the chosen solvent system, collecting fractions.
- Monitor the fractions by thin-layer chromatography (TLC) to identify those containing the pure product.
- Combine the pure fractions and remove the solvent under reduced pressure to yield the purified compound.

Analytical Characterization

The identity and purity of 6-Bromotriazolo[1,5-a]pyrazine can be confirmed using standard analytical techniques. While specific spectral data for this exact compound is not readily available, the expected spectroscopic characteristics can be inferred from related structures.

- ^1H NMR: The proton NMR spectrum is expected to show distinct signals for the protons on the triazolopyrazine ring system.
- ^{13}C NMR: The carbon NMR spectrum will provide information on the number and chemical environment of the carbon atoms in the molecule.
- Mass Spectrometry: Mass spectrometry will confirm the molecular weight of the compound. High-resolution mass spectrometry (HRMS) can be used to confirm the elemental composition.

Suzuki-Miyaura Cross-Coupling Reaction

The bromine atom on the 6-Bromotriazolo[1,5-a]pyrazine scaffold is well-suited for palladium-catalyzed Suzuki-Miyaura cross-coupling reactions, enabling the introduction of various aryl or heteroaryl groups.

Representative Protocol:

- To a reaction vessel, add 6-Bromotriazolo[1,5-a]pyrazine, an arylboronic acid (1.1-1.5 equivalents), a palladium catalyst (e.g., $\text{Pd}(\text{PPh}_3)_4$, 2-5 mol%), and a base (e.g., K_2CO_3 or Cs_2CO_3 , 2-3 equivalents).
- Add a suitable solvent system, such as a mixture of 1,4-dioxane and water.
- Degas the mixture by bubbling with an inert gas (e.g., argon or nitrogen) for 10-15 minutes.
- Heat the reaction mixture at a specified temperature (typically 80-100 °C) for several hours, monitoring the progress by TLC or LC-MS.
- Upon completion, cool the reaction to room temperature and perform an aqueous workup.
- Extract the product with an organic solvent (e.g., ethyl acetate), dry the organic layer over anhydrous sodium sulfate, and concentrate under reduced pressure.

- Purify the crude product by column chromatography to obtain the desired coupled product.

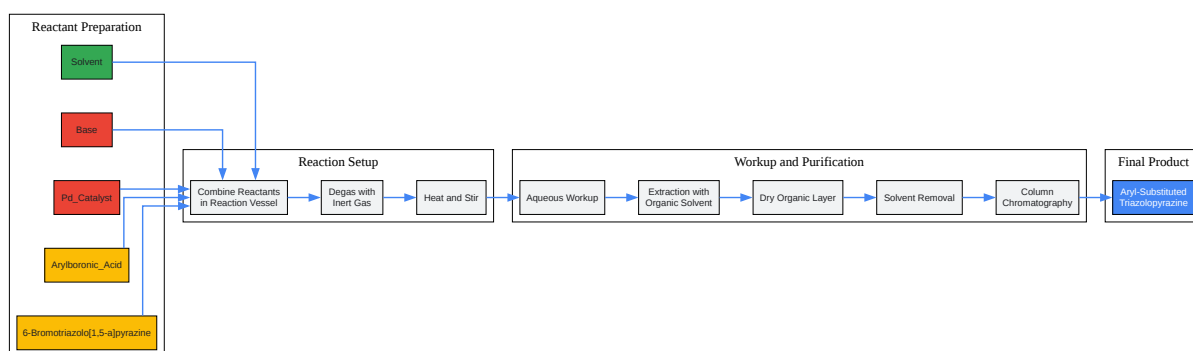

[Click to download full resolution via product page](#)

Experimental workflow for the Suzuki-Miyaura cross-coupling reaction.

Biological Context: Targeting the PI3K/Akt/mTOR Signaling Pathway

The triazolopyridine scaffold is a privileged structure in medicinal chemistry, frequently utilized in the design of kinase inhibitors. Derivatives of nitrogen-containing heterocycles, including triazines, have shown inhibitory activity against the PI3K/Akt/mTOR signaling pathway.[5] This pathway is a critical regulator of cell proliferation, growth, survival, and metabolism, and its dysregulation is a hallmark of many cancers.[5]

Inhibitors targeting this pathway can prevent the phosphorylation cascade that leads to uncontrolled cell growth. A hypothetical inhibitor derived from the 6-Bromotriazolo[1,5-a]pyrazine scaffold could be designed to bind to the ATP-binding pocket of one of the key kinases in this pathway, such as PI3K, Akt, or mTOR, thereby blocking its activity.

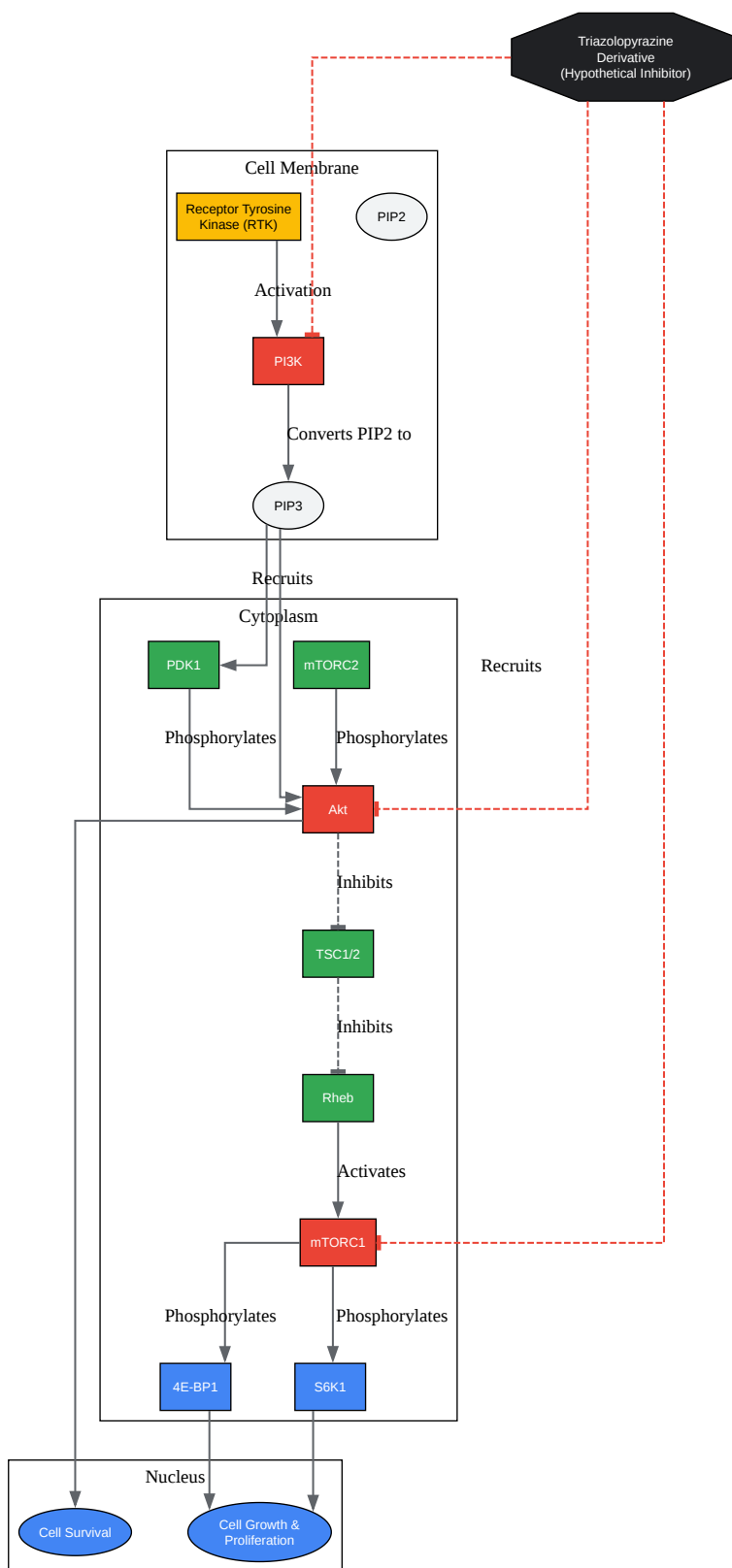

[Click to download full resolution via product page](#)

The PI3K/Akt/mTOR signaling pathway and potential points of inhibition.

Conclusion

6-Bromotriazolo[1,5-a]pyrazine is a highly valuable and versatile chemical intermediate with significant potential in drug discovery and medicinal chemistry. Its adaptable scaffold, particularly its utility in Suzuki-Miyaura cross-coupling reactions, allows for the synthesis of a wide range of derivatives. The demonstrated link between related heterocyclic structures and the inhibition of key cellular signaling pathways, such as the PI3K/Akt/mTOR pathway, underscores the importance of this compound in the development of novel therapeutics. This guide provides a foundational resource for researchers looking to leverage the chemical properties of 6-Bromotriazolo[1,5-a]pyrazine in their scientific endeavors.

Need Custom Synthesis?

BenchChem offers custom synthesis for rare earth carbides and specific isotopic labeling.

Email: info@benchchem.com or [Request Quote Online](#).

References

- 1. chemshuttle.com [chemshuttle.com]
- 2. fluorochem.co.uk [fluorochem.co.uk]
- 3. chembk.com [chembk.com]
- 4. 1184915-33-0|6-Bromo-[1,2,4]triazolo[1,5-a]pyrazin-2-amine|BLD Pharm [bldpharm.com]
- 5. Synthesis and Antiproliferative Activity of a New Series of Mono- and Bis(dimethylpyrazolyl)-s-triazine Derivatives Targeting EGFR/PI3K/AKT/mTOR Signaling Cascades - PMC [pmc.ncbi.nlm.nih.gov]
- To cite this document: BenchChem. [6-Bromotriazolo[1,5-a]pyrazine: A Comprehensive Technical Guide for Researchers]. BenchChem, [2025]. [Online PDF]. Available at: [https://www.benchchem.com/product/b567526#6-bromotriazolo-1-5-a-pyrazine-chemical-properties]

Disclaimer & Data Validity:

The information provided in this document is for Research Use Only (RUO) and is strictly not intended for diagnostic or therapeutic procedures. While BenchChem strives to provide

accurate protocols, we make no warranties, express or implied, regarding the fitness of this product for every specific experimental setup.

Technical Support: The protocols provided are for reference purposes. Unsure if this reagent suits your experiment? [[Contact our Ph.D. Support Team for a compatibility check](#)]

Need Industrial/Bulk Grade? [Request Custom Synthesis Quote](#)

BenchChem

Our mission is to be the trusted global source of essential and advanced chemicals, empowering scientists and researchers to drive progress in science and industry.

Contact

Address: 3281 E Guasti Rd

Ontario, CA 91761, United States

Phone: (601) 213-4426

Email: info@benchchem.com