

Introduction: The Imperative for Unambiguous Structural Verification

Author: BenchChem Technical Support Team. **Date:** May 2026

Compound of Interest

Compound Name:	1-(3,4-Dichlorophenyl)pentan-1-one
CAS No.:	68120-72-9
Cat. No.:	B1586451

[Get Quote](#)

In the realms of pharmaceutical development and agrochemical synthesis, the precise molecular architecture of a compound dictates its function, efficacy, and safety profile. **1-(3,4-Dichlorophenyl)pentan-1-one** (CAS No: 68120-72-9) is a key chemical intermediate utilized in the synthesis of various organic compounds, including potential new drug candidates and agrochemicals.^[1] Its molecular formula is C₁₁H₁₂Cl₂O.^{[2][3]} Given its role as a foundational building block, rigorous and unequivocal confirmation of its structure is not merely an academic exercise but a critical step in quality control and regulatory compliance.

This technical guide provides a comprehensive, multi-technique approach to the structure elucidation of **1-(3,4-Dichlorophenyl)pentan-1-one**. We will move beyond a simple recitation of data, delving into the strategic rationale behind the selection of analytical techniques and the synergistic interpretation of the resulting data. The workflow described herein represents a self-validating system, where evidence from each independent analysis converges to build an unassailable structural assignment.

Visualizing the Target Structure

A clear hypothesis of the target structure is the first step in any elucidation workflow. This allows for the prediction of expected analytical data, against which experimental results can be compared.

Caption: Proposed structure of **1-(3,4-Dichlorophenyl)pentan-1-one** with atom numbering.

Part 1: Mass Spectrometry – The Molecular Blueprint

Expertise & Experience: The initial and most fundamental question in structure elucidation is "What is the molecular weight?". Electron Ionization Mass Spectrometry (EI-MS) provides this answer and offers the first glimpse into the molecule's composition through predictable fragmentation patterns. For a molecule containing chlorine, the isotopic distribution is a powerful confirmatory tool.

Experimental Protocol: Electron Ionization Mass Spectrometry (EI-MS)

- **Sample Preparation:** A dilute solution of the analyte is prepared in a volatile solvent (e.g., methanol or dichloromethane).
- **Introduction:** The sample is introduced into the mass spectrometer, often via a Gas Chromatography (GC) system for purification and separation (GC-MS).[4]
- **Ionization:** The sample is bombarded with high-energy electrons (typically 70 eV), causing the molecule to lose an electron and form a positively charged molecular ion ($M^{\bullet+}$).[5]
- **Fragmentation:** The high energy of the molecular ion causes it to fragment into smaller, characteristic charged ions and neutral radicals.[5]
- **Analysis:** The positively charged ions are accelerated and separated based on their mass-to-charge ratio (m/z).
- **Detection:** The abundance of each ion is measured, generating a mass spectrum.

Data Interpretation and Trustworthiness

The mass spectrum provides two layers of validation: the molecular ion and the fragmentation pattern.

1. The Molecular Ion (M^+): The molecular weight of $C_{11}H_{12}Cl_2O$ is 230.0265 g/mol for the most common isotopes (^{12}C , 1H , ^{35}Cl , ^{16}O).^[2] A key validation step is observing the isotopic pattern of chlorine. Chlorine has two stable isotopes: ^{35}Cl (~75.8% abundance) and ^{37}Cl (~24.2% abundance). For a molecule with two chlorine atoms, the mass spectrum will exhibit a characteristic cluster of peaks:

- M^+ peak: Contains two ^{35}Cl isotopes. (Relative abundance = 100%)
- $M+2$ peak: Contains one ^{35}Cl and one ^{37}Cl isotope. (Relative abundance \approx 65%)
- $M+4$ peak: Contains two ^{37}Cl isotopes. (Relative abundance \approx 10%)

Observing this ~100:65:10 ratio in the m/z 230, 232, and 234 region provides high confidence in the presence of two chlorine atoms.

2. Key Fragmentation Pathways: Energetically unstable molecular ions break apart in predictable ways, providing structural clues.^[5] For **1-(3,4-Dichlorophenyl)pentan-1-one**, two primary fragmentations are expected:

- Alpha-Cleavage: The bond between the carbonyl carbon and the alkyl chain is weak and prone to cleavage. This results in the formation of a stable acylium ion. This is often a favored fragmentation pathway for ketones.^[4]
- McLafferty Rearrangement: This is a characteristic fragmentation for carbonyl compounds with a sufficiently long alkyl chain (at least three carbons long with a γ -hydrogen).^[4] It involves the transfer of a hydrogen atom from the γ -carbon to the carbonyl oxygen, followed by the cleavage of the α - β carbon bond.

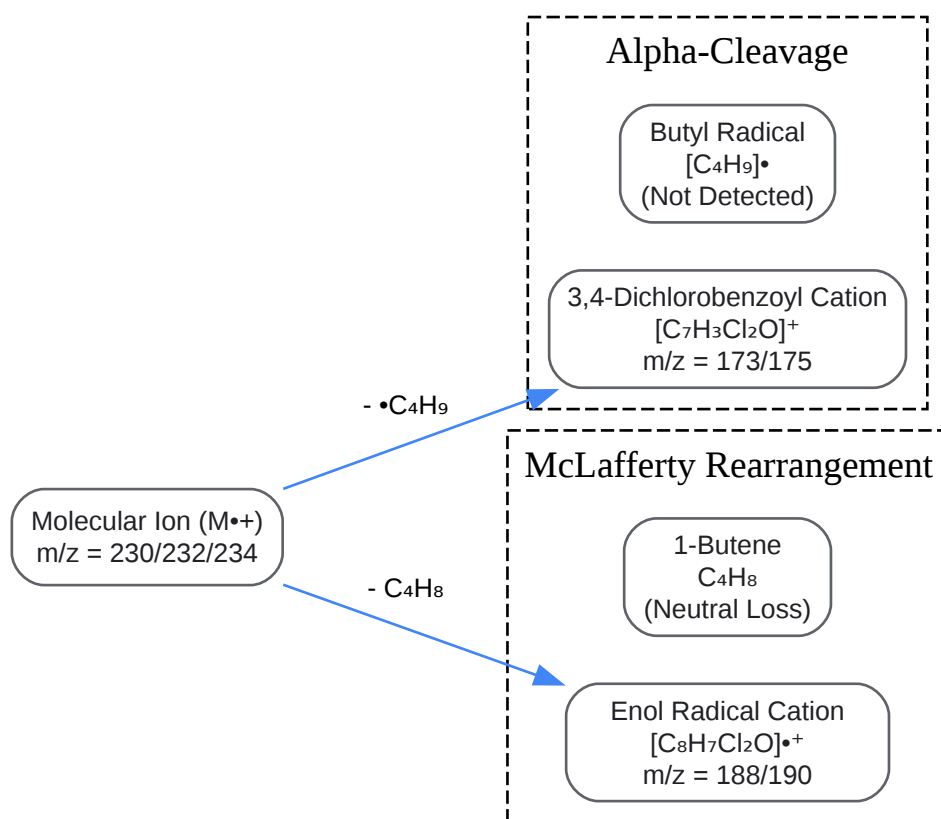

[Click to download full resolution via product page](#)

Caption: Predicted major fragmentation pathways in the EI-MS of the target compound.

Data Summary

Ion Description	Predicted m/z (for ³⁵ Cl)	Significance
Molecular Ion (M ^{•+})	230	Confirms molecular weight.
M+2 Peak	232	Confirms presence of two Cl atoms.
M+4 Peak	234	Confirms presence of two Cl atoms.
Acylium Cation	173	Confirms dichlorobenzoyl substructure.
McLafferty Fragment	188	Supports the presence of a pentanoyl chain.

Part 2: Infrared (IR) Spectroscopy – Functional Group Fingerprinting

Expertise & Experience: IR spectroscopy is a rapid and non-destructive technique that excels at identifying the functional groups present in a molecule. The principle lies in the absorption of specific frequencies of IR radiation that correspond to the vibrational energies of molecular bonds. For our target compound, the most telling absorption will be the strong, sharp peak from the carbonyl (C=O) group.

Experimental Protocol: Attenuated Total Reflectance (ATR) FT-IR

- **Instrument Setup:** Perform a background scan to account for atmospheric CO₂ and H₂O.
- **Sample Application:** Apply a small amount of the neat liquid or solid sample directly onto the ATR crystal (e.g., diamond or germanium).
- **Data Acquisition:** An IR beam is passed through the crystal and reflects off the internal surface in contact with the sample. The sample absorbs energy at specific frequencies, and the attenuated beam is measured by a detector.
- **Spectrum Generation:** A Fourier Transform (FT) is applied to the signal to generate the final spectrum of absorbance vs. wavenumber.

Data Interpretation and Trustworthiness

The IR spectrum of an aromatic ketone has several characteristic regions. The presence of a strong absorption in the 1670-1780 cm⁻¹ range is a clear indicator of a carbonyl group.^{[6][7]}

- **Carbonyl (C=O) Stretch:** For aromatic ketones, conjugation of the carbonyl group with the benzene ring lowers the vibrational frequency compared to a saturated ketone (which appears around 1715 cm⁻¹).^[8] A strong, sharp peak is expected around 1690 cm⁻¹.^{[8][9]}
- **Aromatic C=C Stretch:** Medium to weak absorptions in the 1450-1600 cm⁻¹ region are characteristic of the benzene ring.

- Aromatic C-H Stretch: These appear as a group of weaker absorptions just above 3000 cm^{-1} .
- Aliphatic C-H Stretch: Stronger absorptions from the pentanoyl chain will be visible just below 3000 cm^{-1} (typically 2850-2960 cm^{-1}).^[7]
- C-Cl Stretch: Absorptions for the C-Cl bonds are typically found in the fingerprint region, between 600-800 cm^{-1} .

Data Summary

Vibrational Mode	Expected Wavenumber (cm^{-1})	Intensity	Significance
Aromatic C-H Stretch	3000 - 3100	Weak-Medium	Presence of aromatic ring.
Aliphatic C-H Stretch	2850 - 2960	Strong	Presence of alkyl chain.
Carbonyl (C=O) Stretch	~1690	Strong, Sharp	Confirms conjugated ketone.
Aromatic C=C Stretch	1450 - 1600	Medium	Confirms aromatic ring.
C-Cl Stretch	600 - 800	Medium-Strong	Supports presence of chlorine.

Part 3: Nuclear Magnetic Resonance (NMR) Spectroscopy – The Definitive Map

Expertise & Experience: While MS gives the mass and IR identifies functional groups, NMR spectroscopy maps the carbon-hydrogen framework of the molecule, revealing how atoms are connected. It is the most powerful tool for unambiguous structure elucidation in solution. We utilize both ^1H and ^{13}C NMR to create a complete picture.

Experimental Protocol: ^1H and ^{13}C NMR

- **Sample Preparation:** Dissolve 5-10 mg of the purified sample in ~0.6 mL of a deuterated solvent (e.g., Chloroform-d, CDCl_3). Add a small amount of an internal standard like Tetramethylsilane (TMS, $\delta = 0.00$ ppm).
- **Instrument Tuning:** Place the NMR tube in the spectrometer. The instrument is tuned to the specific nucleus (^1H or ^{13}C) and the magnetic field is "shimmed" to ensure homogeneity.
- **^1H NMR Acquisition:** A standard proton spectrum is acquired. Key parameters include the number of scans, pulse width, and relaxation delay.
- **^{13}C NMR Acquisition:** A broadband proton-decoupled ^{13}C spectrum is acquired. This provides a single peak for each unique carbon atom. More scans are required due to the lower natural abundance of ^{13}C .
- **Data Processing:** The raw data (Free Induction Decay, FID) is Fourier transformed, phased, and baseline corrected to produce the final spectrum.

^1H NMR Data Interpretation

The ^1H NMR spectrum provides four key pieces of information: number of signals (unique proton environments), chemical shift (electronic environment), integration (number of protons), and multiplicity (neighboring protons).

Protons (See Structure)	Predicted δ (ppm)	Multiplicity	Integration	Rationale
H-C5	~0.95	Triplet (t)	3H	Terminal methyl group, split by 2 protons on C4.
H-C4	~1.40	Sextet	2H	Split by 3 protons on C5 and 2 protons on C3.
H-C3	~1.70	Quintet	2H	Split by 2 protons on C4 and 2 protons on C2.
H-C2	~2.95	Triplet (t)	2H	α - to carbonyl, deshielded. Split by 2 protons on C3.
H-C6'	~7.50	Doublet (d)	1H	Aromatic proton ortho to carbonyl, ortho to Cl.
H-C5'	~7.65	Doublet of Doublets (dd)	1H	Aromatic proton meta to carbonyl, between two Cl atoms.
H-C2'	~7.85	Doublet (d)	1H	Aromatic proton ortho to carbonyl, meta to Cl. Deshielded.

¹³C NMR Data Interpretation

The ¹³C NMR spectrum shows a single peak for each unique carbon environment. The chemical shift is highly indicative of the carbon type.

Carbon Atom (See Structure)	Predicted δ (ppm)	Rationale
C1 (C=O)	~198.5	Carbonyl carbon, highly deshielded.[9]
C1'	~136.0	Aromatic carbon attached to the carbonyl group.
C2', C6'	~129.0 - 131.0	Aromatic C-H carbons.
C5'	~132.0	Aromatic C-H carbon.
C3', C4'	~134.0 - 138.0	Aromatic carbons attached to chlorine, deshielded.
C2	~38.5	α -carbon to carbonyl.
C3	~26.5	Aliphatic carbon.
C4	~22.5	Aliphatic carbon.
C5	~14.0	Terminal methyl carbon.

Part 4: X-ray Crystallography – The Gold Standard

For absolute and unambiguous proof of structure, single-crystal X-ray crystallography is the definitive technique.[10][11] It provides a three-dimensional model of the molecule as it exists in the crystal lattice, confirming not only connectivity but also stereochemistry and conformation.[10]

Causality Behind Use: While the spectroscopic data provides overwhelming evidence, X-ray crystallography serves as the ultimate arbiter, especially for regulatory submissions or when subtle stereochemical questions are at play. The primary challenge is often not the analysis itself, but the ability to grow a single, high-quality crystal suitable for diffraction.[11]

Experimental Workflow

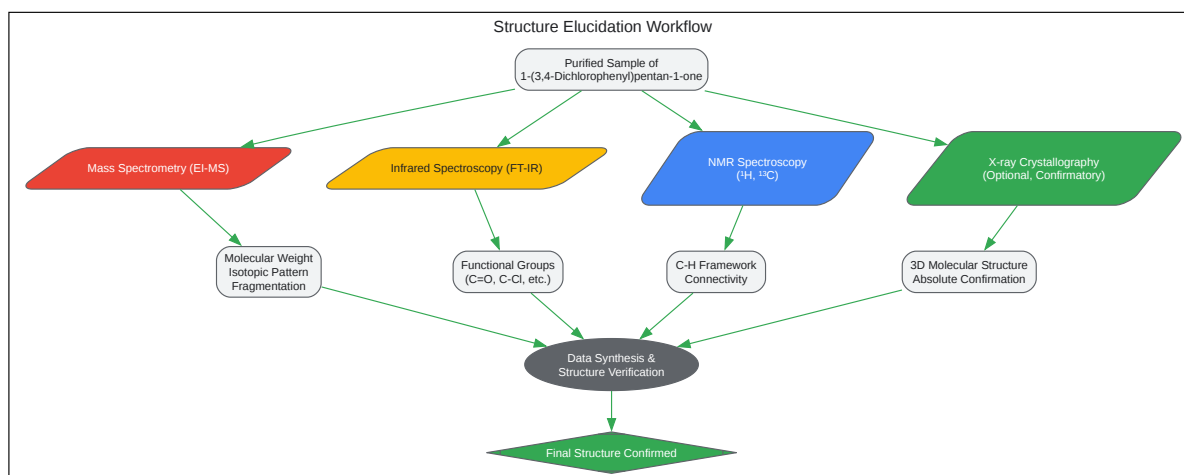

[Click to download full resolution via product page](#)

Caption: A comprehensive workflow for the structural elucidation of a novel compound.

Conclusion: A Synergistic Approach to Certainty

The structure elucidation of **1-(3,4-Dichlorophenyl)pentan-1-one** is achieved not by a single technique, but by the logical synthesis of data from orthogonal analytical methods.

- Mass Spectrometry confirms the elemental composition ($C_{11}H_{12}Cl_2O$) via the molecular weight and the characteristic chlorine isotope pattern.

- Infrared Spectroscopy provides a rapid and definitive confirmation of the key conjugated ketone functional group ($\sim 1690\text{ cm}^{-1}$).
- NMR Spectroscopy provides the final, unambiguous map of the molecule, detailing the precise arrangement and connectivity of every hydrogen and carbon atom.

Each piece of evidence validates the others, creating a self-consistent and trustworthy conclusion. This rigorous, multi-faceted approach ensures the highest degree of confidence in the molecular structure, a prerequisite for any further research or development involving this important chemical intermediate.

References

- Ballard, C. E. (2010). pH-Controlled Oxidation of an Aromatic Ketone: Structural Elucidation of the Products of Two Green Chemical Reactions. *Journal of Chemical Education*, 87(2), 190-192. Available at: [\[Link\]](#)
- Ballard, C. E. (2010). pH-Controlled Oxidation of an Aromatic Ketone: Structural Elucidation of the Products of Two Green Chemical Reactions. ERIC. Available at: [\[Link\]](#)
- ResearchGate. (n.d.). A, Structure of aromatic ketones... Download Scientific Diagram. Available at: [\[Link\]](#)
- Chemistry LibreTexts. (2024). 12.8: Infrared Spectra of Some Common Functional Groups. Available at: [\[Link\]](#)
- OpenStax. (2023). 12.8 Infrared Spectra of Some Common Functional Groups - Organic Chemistry. Available at: [\[Link\]](#)
- Unacademy. (n.d.). All About Aromatic Ketones. Available at: [\[Link\]](#)
- LookChem. (n.d.). 1-(3,4-DICHLORO-PHENYL)-PENTAN-1-ONE(68120-72-9). Available at: [\[Link\]](#)
- Enthuziastic. (2023). Ketones Structural Formula: Definition, Occurrence, Naming, Uses. Available at: [\[Link\]](#)

- PubChem. (n.d.). **1-(3,4-Dichlorophenyl)pentan-1-one**. National Center for Biotechnology Information. Available at: [\[Link\]](#)
- McMurry, J. (n.d.). 19.14 Spectroscopy of Aldehydes and Ketones. In Organic Chemistry: A Tenth Edition. Available at: [\[Link\]](#)
- Berkeley Learning Hub. (2024). Ketone IR Spectroscopy Analysis. Available at: [\[Link\]](#)
- ResearchGate. (n.d.). X-ray diffraction patterns of o -hydroxy acetophenone azine. Available at: [\[Link\]](#)
- Chemistry LibreTexts. (2025). 19.14: Spectroscopy of Aldehydes and Ketones. Available at: [\[Link\]](#)
- ACS Publications. (n.d.). The Journal of Organic Chemistry Ahead of Print. Available at: [\[Link\]](#)
- Wikipedia. (n.d.). X-ray crystallography. Available at: [\[Link\]](#)
- National Institutes of Health. (n.d.). X-Ray Crystallography of Chemical Compounds. PMC. Available at: [\[Link\]](#)
- ResearchGate. (n.d.). a) ¹H-NMR, b) ¹³C-NMR, and c) ¹³C-DEPT-135-NMR spectra of... Available at: [\[Link\]](#)
- Capot Chemical. (n.d.). Specifications of **1-(3,4-Dichlorophenyl)pentan-1-one**. Available at: [\[Link\]](#)
- The Royal Society of Chemistry. (n.d.). VI. ¹H and ¹³C NMR Spectra. Available at: [\[Link\]](#)
- ResearchGate. (2019). Crystal Structures and Spectroscopic Characterization of Four Synthetic Cathinones... Available at: [\[Link\]](#)
- MDPI. (n.d.). Synthesis and X-ray Crystal Structure Analysis of Substituted 1,2,4-Triazolo [4',3':2,3]pyridazino[4,5-b]indole and Its Precursor. Available at: [\[Link\]](#)
- CORE. (n.d.). Mass Spectrometric Fragmentation of the Tautomers of 1,3=Diketones. Available at: [\[Link\]](#)

- Chemistry LibreTexts. (2023). Fragmentation Patterns in Mass Spectra. Available at: [\[Link\]](#)
- Organic Chemistry Data. (2021). NMR Spectroscopy :: ¹³C NMR Chemical Shifts. Available at: [\[Link\]](#)
- MDPI. (2023). Spectroscopic and Crystallographic Characterization of Two Hydrochloride Cathinones... Available at: [\[Link\]](#)
- PubMed. (1999). Mass spectral fragmentation of cis- and trans-1a,3-disubstituted 1,1-dichloro-1a,2,3,4-tetrahydro-1H-azirino[1,2-a][7][12]benzodiazepines. Available at: [\[Link\]](#)
- Chemistry LibreTexts. (2023). Mass spectrometry 1. Available at: [\[Link\]](#)
- National Institutes of Health. (n.d.). The synthesis, crystal structure and spectroscopic analysis of (E)-3-(4-chlorophenyl)-1-(2,3-dihydrobenzo[b][6][12]dioxin-6-yl)prop-2-en-1-one. Available at: [\[Link\]](#)
- Universitat de València. (n.d.). ¹H and ¹³C NMR signal assignment of synthetic (-)-methyl thyriflorin B acetate... Available at: [\[Link\]](#)
- ResearchGate. (n.d.). The synthesis, crystal structure and spectroscopic analysis of (E)-3-(4-chlorophenyl)-1-(2,3-dihydrobenzo[b][6][12]dioxin-6-yl)prop-2-en-1-one. Available at: [\[Link\]](#)

Need Custom Synthesis?

BenchChem offers custom synthesis for rare earth carbides and specific isotopic labeling.

Email: info@benchchem.com or [Request Quote Online](#).

Sources

- [1. lookchem.com](https://www.lookchem.com) [[lookchem.com](https://www.lookchem.com)]
- [2. pubchem.ncbi.nlm.nih.gov](https://pubchem.ncbi.nlm.nih.gov) [pubchem.ncbi.nlm.nih.gov]
- [3. capotchem.com](https://www.capotchem.com) [[capotchem.com](https://www.capotchem.com)]
- [4. chem.libretexts.org](https://chem.libretexts.org) [chem.libretexts.org]
- [5. chem.libretexts.org](https://chem.libretexts.org) [chem.libretexts.org]

- [6. chem.libretexts.org \[chem.libretexts.org\]](https://chem.libretexts.org)
- [7. 12.8 Infrared Spectra of Some Common Functional Groups - Organic Chemistry | OpenStax \[openstax.org\]](#)
- [8. 19.14 Spectroscopy of Aldehydes and Ketones – Organic Chemistry: A Tenth Edition – OpenStax adaptation 1 \[ncstate.pressbooks.pub\]](#)
- [9. chem.libretexts.org \[chem.libretexts.org\]](https://chem.libretexts.org)
- [10. X-ray crystallography - Wikipedia \[en.wikipedia.org\]](https://en.wikipedia.org)
- [11. X-Ray Crystallography of Chemical Compounds - PMC \[pmc.ncbi.nlm.nih.gov\]](https://pubmed.ncbi.nlm.nih.gov)
- [12. pubs.acs.org \[pubs.acs.org\]](https://pubs.acs.org)
- To cite this document: BenchChem. [Introduction: The Imperative for Unambiguous Structural Verification]. BenchChem, [2026]. [Online PDF]. Available at: [\[https://www.benchchem.com/product/b1586451/docs#introduction-the-imperative-for-unambiguous-structural-verification\]](https://www.benchchem.com/product/b1586451/docs#introduction-the-imperative-for-unambiguous-structural-verification)

Disclaimer & Data Validity:

The information provided in this document is for Research Use Only (RUO) and is strictly not intended for diagnostic or therapeutic procedures. While BenchChem strives to provide accurate protocols, we make no warranties, express or implied, regarding the fitness of this product for every specific experimental setup.

Technical Support: The protocols provided are for reference purposes. Unsure if this reagent suits your experiment?

Need Industrial/Bulk Grade? [Request Custom Synthesis Quote](#)

BenchChem

Our mission is to be the trusted global source of essential and advanced chemicals, empowering scientists and researchers to drive progress in science and industry.

Contact

Address: 3281 E Guasti Rd
Ontario, CA 91761, United States
Phone: (601) 213-4426
Email: info@benchchem.com

Contact our Ph.D. Support Team for a compatibility check