

Application Note: Synthesis Protocol for Di-(2-picolyl)aminomethyl BODIPY

Author: BenchChem Technical Support Team. **Date:** May 2026

Compound of Interest

Compound Name: *Di-(2-picolyl)aminomethyl BODIPY*

CAS No.: 1187315-90-7

Cat. No.: B565619

[Get Quote](#)

Abstract

This application note details the synthesis, purification, and characterization of 8-((di(2-picolyl)amino)methyl)-4,4-difluoro-1,3,5,7-tetramethyl-4-bora-3a,4a-diaza-s-indacene (BODIPY-DPA). This conjugate functions as a highly specific "Turn-ON" fluorescent sensor for transition metal ions, particularly Zinc (Zn^{2+}) and Cadmium (Cd^{2+}), utilizing the Photoinduced Electron Transfer (PET) mechanism. The protocol employs a modular two-step synthetic route: (1) the construction of a reactive meso-chloromethyl BODIPY core, followed by (2) a nucleophilic substitution with dipicolylamine (DPA). This guide is designed for medicinal chemists and chemical biologists requiring high-purity probes for intracellular ion imaging.

Introduction & Mechanism of Action

Significance

BODIPY dyes are renowned for their high quantum yields, sharp emission peaks, and photostability.^{[1][2][3][4]} However, the core itself is insensitive to the environment. By conjugating the BODIPY core with a Di-(2-picolyl)amine (DPA) receptor via a methylene bridge at the meso (C-8) position, the molecule becomes a PET-based sensor.

Sensing Mechanism (PET)

The operation of the sensor relies on the thermodynamic modulation of electron transfer:

- **OFF State (Free Ligand):** The lone pair electrons on the benzylic nitrogen of the DPA moiety possess an energy level between the HOMO and LUMO of the BODIPY fluorophore. Upon excitation of the BODIPY, an electron transfers from the DPA nitrogen to the BODIPY HOMO, quenching fluorescence (non-radiative decay).
- **ON State (Metal Bound):** When a metal ion (e.g., Zn^{2+}) coordinates with the DPA nitrogen, the lone pair energy is lowered (stabilized). This prevents electron transfer to the BODIPY HOMO, restoring the radiative pathway and resulting in strong fluorescence.

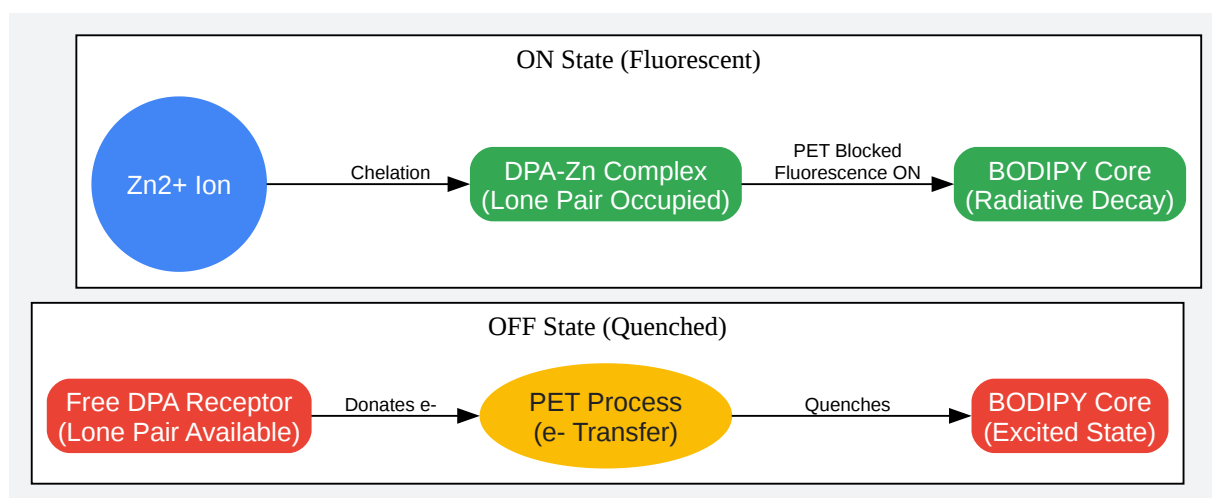

[Click to download full resolution via product page](#)

Figure 1: Logic gate diagram illustrating the Photoinduced Electron Transfer (PET) mechanism switching from OFF to ON upon metal chelation.

Materials & Reagents

Reagent	CAS Number	Role	Purity Grade
2,4-Dimethylpyrrole	625-82-1	Starting Material	>97%
Chloroacetyl chloride	79-04-9	Electrophile	>98%
Boron trifluoride diethyl etherate	109-63-7	Complexing Agent	Synthesis Grade
Triethylamine (Et ₃ N)	121-44-8	Base	Anhydrous
Di-(2-picoly)amine (DPA)	1239-64-1	Receptor Ligand	>97%
Potassium Carbonate (K ₂ CO ₃)	584-08-7	Base (Step 2)	Anhydrous, Powder
Potassium Iodide (KI)	7681-11-0	Catalyst (Finkelstein)	>99%
Dichloromethane (DCM)	75-09-2	Solvent	Anhydrous
Acetonitrile (MeCN)	75-05-8	Solvent	Anhydrous

Experimental Protocol

Synthetic Route Overview

The synthesis is a linear two-step process. The meso-chloromethyl handle is installed first, providing a versatile electrophile for the subsequent attachment of the bulky DPA group.

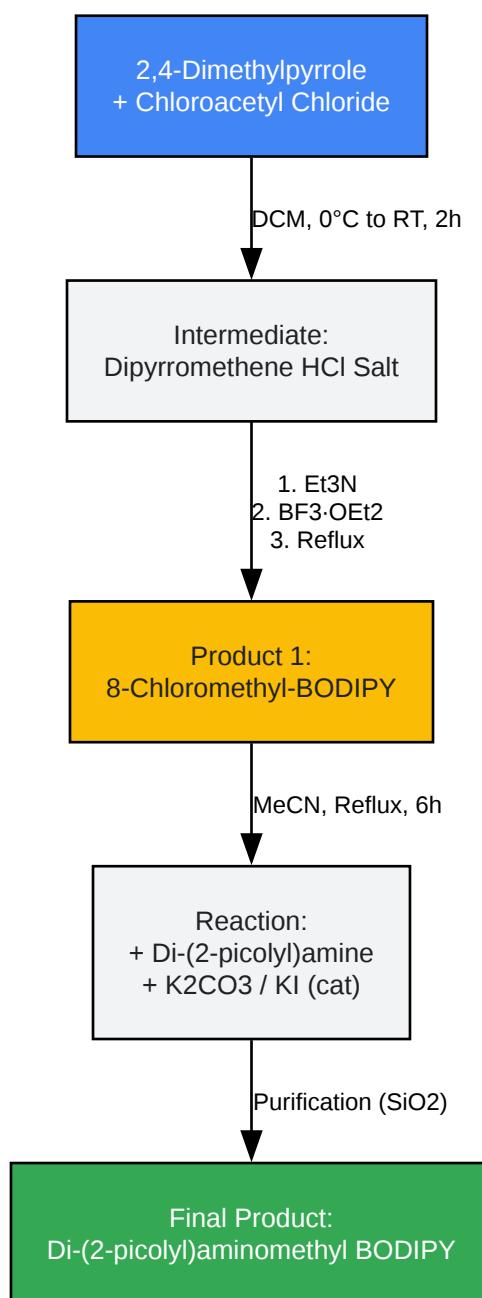

[Click to download full resolution via product page](#)

Figure 2: Step-wise synthetic workflow for the target BODIPY-DPA conjugate.

Step 1: Synthesis of meso-Chloromethyl BODIPY

Objective: Synthesize 8-chloromethyl-4,4-difluoro-1,3,5,7-tetramethyl-4-bora-3a,4a-diaza-s-indacene.

- Condensation:

- In a flame-dried 250 mL round-bottom flask (RBF) under Argon, dissolve 2,4-dimethylpyrrole (2.0 g, 21.0 mmol, 2.0 eq) in anhydrous DCM (80 mL).
- Cool the solution to 0°C using an ice bath.
- Dropwise add chloroacetyl chloride (1.19 g, 10.5 mmol, 1.0 eq) dissolved in 10 mL DCM over 15 minutes. The solution will turn dark red/brown.
- Critical Step: Allow the mixture to warm to room temperature (RT) and stir for 2–3 hours. Monitor by TLC (disappearance of pyrrole). Note: This forms the unstable dipyrromethene hydrochloride salt.
- Complexation:
 - Cool the mixture back to 0°C.
 - Add Triethylamine (4.5 mL, 32 mmol, ~3 eq) dropwise. Stir for 15 minutes.
 - Add $\text{BF}_3 \cdot \text{OEt}_2$ (6.0 mL, 48 mmol, ~4.5 eq) dropwise carefully (exothermic).
 - Remove the ice bath and stir at RT for 1 hour.
 - (Optional but recommended): Reflux the mixture for 1 hour to ensure complete boron complexation.
- Workup & Purification:
 - Quench with water (100 mL). Extract the organic layer.[5]
 - Wash the organic layer with 0.1 M HCl (2 x 50 mL) to remove excess amine, followed by saturated NaHCO_3 and brine.
 - Dry over Na_2SO_4 , filter, and concentrate in vacuo.
 - Column Chromatography: Silica gel, eluting with DCM/Hexane (1:1). The product is a bright fluorescent orange/red solid.
 - Expected Yield: 30–40%.

Step 2: Substitution with Di-(2-picolyl)amine (DPA)

Objective: Nucleophilic displacement of the chloride by DPA.

- Reaction Setup:
 - In a 50 mL RBF, dissolve 8-chloromethyl-BODIPY (100 mg, 0.33 mmol, 1.0 eq) in anhydrous Acetonitrile (MeCN) (15 mL).
 - Add Potassium Carbonate (K_2CO_3) (138 mg, 1.0 mmol, 3.0 eq).
 - Add Potassium Iodide (KI) (10 mg, catalytic). Expert Tip: KI generates the iodomethyl intermediate in situ, which is a better electrophile (Finkelstein reaction), significantly accelerating the reaction.
 - Add Di-(2-picolyl)amine (80 mg, 0.40 mmol, 1.2 eq).
- Execution:
 - Reflux the mixture (approx. 82°C) under Argon for 4–6 hours.
 - Monitoring: Check TLC (DCM/MeOH 95:5). The starting material (high R_f in non-polar) should disappear, and a new, slightly more polar spot (product) should appear. Note: The product may be less fluorescent on the TLC plate than the starting material due to PET quenching.
- Workup:
 - Cool to RT and filter off the inorganic solids (K_2CO_3 /KCl).
 - Concentrate the filtrate to dryness.
 - Redissolve in DCM (30 mL) and wash with water (2 x 20 mL). Caution: Do not use acidic wash here, as it will protonate the DPA and extract the product into the aqueous phase.
- Purification:
 - Column Chromatography: Silica gel.

- Eluent: Start with 100% DCM, then gradient to DCM/MeOH (98:2 to 95:5).
- Isolate the dark orange/red solid.
- Expected Yield: 60–75%.

Characterization & Validation

NMR Spectroscopy (¹H NMR, 400 MHz, CDCl₃)

The success of the synthesis is validated by the shift of the meso-methylene protons.

Proton Environment	Chemical Shift (δ ppm)	Multiplicity	Integration	Diagnostic Note
Py-H (Aromatic)	8.5 – 7.1	Multiplets	8H	Characteristic pyridine pattern.
BODIPY-CH (β-pyrrole)	~6.0	Singlet	2H	Core protons.
N-CH ₂ -Py	~3.9 – 4.0	Singlet	4H	Picolyl methylene protons.
BODIPY-CH ₂ -N	~4.2 – 4.4	Singlet	2H	Key Signal: Upfield shift from ~4.9 ppm (Cl-CH ₂) confirms substitution.
BODIPY-CH ₃	2.5 & 1.3	Singlets	12H	1,3,5,7-Methyl groups.

Mass Spectrometry

- Technique: ESI-MS or MALDI-TOF.
- Expected Ion: [M+H]⁺ or [M+Na]⁺.

- Molecular Formula: $C_{27}H_{29}BF_2N_5$ (Calculated MW: ~ 472.3 g/mol).

Fluorescence Titration (Functional Assay)

To verify the sensor capability:

- Prepare a 10 μ M solution of the product in MeCN/Water (1:1, buffered at pH 7.2 with HEPES).
- Measure fluorescence emission (Excitation: ~ 490 nm). The signal should be low (Quenched).
- Add aliquots of $Zn(ClO_4)_2$ or $ZnCl_2$.
- Result: Fluorescence intensity at ~ 510 nm should increase significantly (Turn-ON) and plateau at 1:1 stoichiometry.

Troubleshooting & Expert Tips

- Instability of Dipyrromethene: In Step 1, do not attempt to isolate the dipyrromethene intermediate. It is unstable to air and light. Proceed directly to the BF_2 complexation in the same pot.
- Water Sensitivity: The $BF_3 \cdot OEt_2$ complexation step is moisture-sensitive. Ensure glassware is flame-dried and reagents are anhydrous.
- Purification Difficulty: If the DPA-BODIPY product streaks on the silica column, add 1% Triethylamine to the eluent to deactivate acidic sites on the silica.
- Low Yield in Step 2: If the reaction is sluggish, ensure the KI is fresh. Old KI oxidizes to iodine (yellow/brown) and is less effective. Alternatively, use Cs_2CO_3 as a stronger base, but watch for degradation.

Safety Considerations

- Chloroacetyl Chloride: Highly corrosive and lachrymator. Handle only in a fume hood.

- $\text{BF}_3 \cdot \text{OEt}_2$: Corrosive and moisture-sensitive. Releases HF upon hydrolysis. Use plastic syringes or glass syringes with PTFE plungers; avoid metal needles if possible or clean immediately.
- BODIPY Dyes: Generally non-toxic but should be treated as unknown chemicals. Avoid inhalation of silica dust during column chromatography.

References

- Loudet, A., & Burgess, K. (2007). BODIPY dyes and their derivatives: syntheses and spectroscopic properties. *Chemical Reviews*, 107(11), 4891-4932. [Link](#)
- Cheng, T., Xu, Y., Zhang, S., Zhu, W., Qian, X., & Duan, L. (2010). A highly sensitive and selective OFF-ON fluorescent sensor for Zn^{2+} based on the BODIPY fluorophore and its application in living cells. *Journal of the American Chemical Society*, 132(12), 4052-4053.
- Boens, N., Leen, V., & Dehaen, W. (2012). Fluorescent indicators based on BODIPY. *Chemical Society Reviews*, 41(3), 1130-1172. [Link](#)
- Lakowicz, J. R. (2006). *Principles of Fluorescence Spectroscopy*. Springer.
- Turfan, B., & Akkaya, E. U. (2002). Modulation of the cation binding ability of crown ethers by styryl-BODIPY dyes. *Organic Letters*, 4(17), 2857-2859. (Reference for DPA-BODIPY sensing concepts).

Need Custom Synthesis?

BenchChem offers custom synthesis for rare earth carbides and specific isotopic labeling.

Email: info@benchchem.com or [Request Quote Online](#).

Sources

- 1. probes.bocsci.com [probes.bocsci.com]
- 2. [Synthesis of Functional Fluorescent BODIPY-based Dyes through Electrophilic Aromatic Substitution: Straightforward Approach towards Customized Fluorescent Probes - PMC](#) [pmc.ncbi.nlm.nih.gov]
- 3. mocsci.com [mocsci.com]

- [4. Stepwise Polychlorination of 8-Chloro-BODIPY and Regioselective Functionalization of 2,3,5,6,8-Pentachloro-BODIPY - PMC \[pmc.ncbi.nlm.nih.gov\]](#)
- [5. mdpi.com \[mdpi.com\]](#)
- To cite this document: BenchChem. [Application Note: Synthesis Protocol for Di-(2-picolyl)aminomethyl BODIPY]. BenchChem, [2026]. [Online PDF]. Available at: [<https://www.benchchem.com/product/b565619/docs#application-note-synthesis-protocol-for-di-2-picolyl-aminomethyl-bodipy>]

Disclaimer & Data Validity:

The information provided in this document is for Research Use Only (RUO) and is strictly not intended for diagnostic or therapeutic procedures. While BenchChem strives to provide accurate protocols, we make no warranties, express or implied, regarding the fitness of this product for every specific experimental setup.

Technical Support: The protocols provided are for reference purposes. Unsure if this reagent suits your experiment?

Need Industrial/Bulk Grade? [Request Custom Synthesis Quote](#)

BenchChem

Our mission is to be the trusted global source of essential and advanced chemicals, empowering scientists and researchers to drive progress in science and industry.

Contact

Address: 3281 E Guasti Rd
Ontario, CA 91761, United States
Phone: (601) 213-4426
Email: info@benchchem.com

[Contact our Ph.D. Support Team for a compatibility check](#)

