

Enhancing detection sensitivity of low-abundance lipids

Author: BenchChem Technical Support Team. **Date:** May 2026

Compound of Interest

Compound Name: *(cis-9)-2-Hydroxyoctadecen-17-ynoic Acid*

CAS No.: *1159977-43-1*

Cat. No.: *B564529*

[Get Quote](#)

Technical Support Center: Enhancing Detection Sensitivity of Low-Abundance Lipids

Welcome to the Advanced Lipidomics Support Hub. This guide addresses the technical bottlenecks preventing the detection of low-abundance lipid species (e.g., signaling lipids, oxidized phospholipids, and specific isomers). It is designed for researchers requiring femtomolar-level sensitivity.

Module 1: Sample Preparation & Extraction Efficiency

Core Directive: You cannot detect what you fail to extract. For low-abundance lipids, standard protocols (Folch/Bligh & Dyer) often fail due to phase partitioning losses or degradation.

Troubleshooting Guide

Q1: I am targeting low-abundance phosphoinositides (PIPs) and phosphatidic acids (PA), but my recovery is inconsistent. Why? Diagnosis: Standard neutral extractions cause these acidic

lipids to bind to proteins or glass surfaces, or partition poorly into the organic phase. Solution: Implement an Acidified Liquid-Liquid Extraction.

- Mechanism: Acidification suppresses the ionization of phosphate groups, rendering the lipids more hydrophobic and driving them into the organic phase.
- Protocol Adjustment: Use the Acidified Bligh & Dyer method. Add 0.1M HCl or dilute acetic acid to the aqueous phase during extraction.
- Critical Step: Use silanized glass or low-binding plasticware to prevent adsorption loss.

Q2: My oxidized lipid (oxylipin) signals are buried in noise. Is my extraction destroying them?

Diagnosis: Oxylipins are extremely labile and prone to ex vivo oxidation, creating a high background of artifactual species that masks the biological signal. Solution: Integrate Antioxidant Shielding & Cryo-Extraction.

- Protocol:
 - Add BHT (Butylated hydroxytoluene) (50 µg/mL) and TPP (Triphenylphosphine) to the extraction solvent immediately. TPP specifically reduces hydroperoxides to more stable hydroxides, simplifying the spectra.
 - Perform all steps on ice or at 4°C.
 - Flush all headspace with Argon or Nitrogen gas.

Comparative Data: Extraction Efficiency for Signaling Lipids

Extraction Method	Target Lipid Class	Recovery Efficiency	Pros	Cons
Folch (CHCl ₃ :MeOH)	Bulk Lipids (PC, PE, TG)	>95%	Gold standard for bulk	Toxic; poor recovery of acidic lipids
MTBE (Methyl-tert-butyl ether)	Bulk & Neutral Lipids	>90%	Automatable (floating lipid layer)	Lower recovery for very polar species
Acidified BuOH/EtOAc	Acidic Lipids (PA, PS, PIPs)	>85% (High)	Essential for signaling lipids	Requires evaporation of high-boiling solvents
SPE (Solid Phase Extraction)	Eicosanoids / Oxylipins	>80%	Removes phospholipid matrix	Labor-intensive; potential column loss

Module 2: Chemical Derivatization Strategies

Core Directive: When ionization efficiency is the limiting factor, chemical tagging is the amplifier. This transforms "silent" lipids into highly ionizable species.

Troubleshooting Guide

Q3: Free Fatty Acids (FFAs) and short-chain organic acids show poor ionization in positive mode. How can I boost sensitivity? Diagnosis: FFAs lack a fixed charge and ionize poorly in positive ESI. Negative mode suffers from high background noise. Solution: Charge-Reversal Derivatization using AMPP or Girard's Reagent.

- Technique: Derivatize carboxyl groups with AMPP (N-(4-aminomethylphenyl)pyridinium).
- Mechanism: AMPP introduces a permanent positive charge (pyridinium ring) to the fatty acid. This shifts detection to Positive ESI, increasing signal-to-noise (S/N) ratio by 10-100 fold.
- Validation: Look for the characteristic reporter ion in MS/MS fragmentation.

Q4: I cannot resolve C=C double bond isomers (e.g., omega-3 vs. omega-6 positions).

Diagnosis: Standard collision-induced dissociation (CID) breaks the weakest bonds (headgroups), not the C=C backbone. Solution: Paternò–Büchi (PB) Photochemical Derivatization.

- Protocol: Irradiate the sample with UV light (254 nm) in the presence of Acetone (the PB reagent).
- Mechanism: Acetone reacts with the C=C double bond to form an oxetane ring. Subsequent MS/MS fragmentation cleaves the ring, yielding diagnostic ions that pinpoint the exact double bond location.

Visualization: Derivatization Workflow

Caption: Decision logic for selecting the correct derivatization strategy based on lipid functional group.

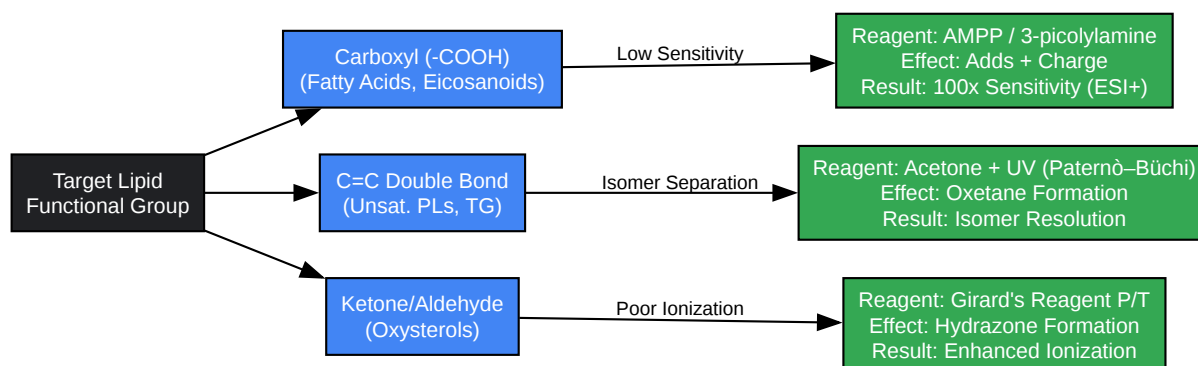

[Click to download full resolution via product page](#)

Module 3: LC-MS/MS & Ion Mobility Optimization

Core Directive: Sensitivity is not just signal height; it is Signal-to-Noise. Reducing noise via separation is as critical as boosting signal.

Troubleshooting Guide

Q5: High-abundance phospholipids (PC/PE) are suppressing my low-abundance analytes. How do I separate them? Diagnosis: Ion Suppression. The "matrix effect" occurs when abundant ions steal charge from trace analytes in the ESI source. Solution: Nano-LC or Ion Mobility Spectrometry (IMS).

- Nano-LC: Switching from analytical flow (0.4 mL/min) to nano-flow (300 nL/min) increases ionization efficiency due to smaller droplet size (fission occurs faster).
- Ion Mobility (IMS): If Nano-LC is not available, use IMS (e.g., FAIMS or TIMS). IMS separates ions by Collision Cross Section (CCS) (shape/size) after ionization but before detection. This physically separates the lipid noise (matrix) from your target analyte in the gas phase.

Q6: Should I use MRM or High-Resolution (HRMS) for femtomolar quantification?

Recommendation: Use MRM (Multiple Reaction Monitoring) on a Triple Quadrupole for absolute quantification of known targets.

- Why: MRM offers the highest duty cycle and sensitivity (S/N) by filtering out all background ions except the specific precursor-product pair.
- HRMS (Orbitrap/Q-TOF): Better for discovery and identifying unknowns, but generally less sensitive than high-end Triple Quads for targeted low-abundance work.

Visualization: Sensitivity Optimization Logic

Caption: Troubleshooting flow for resolving low sensitivity issues in lipidomics.

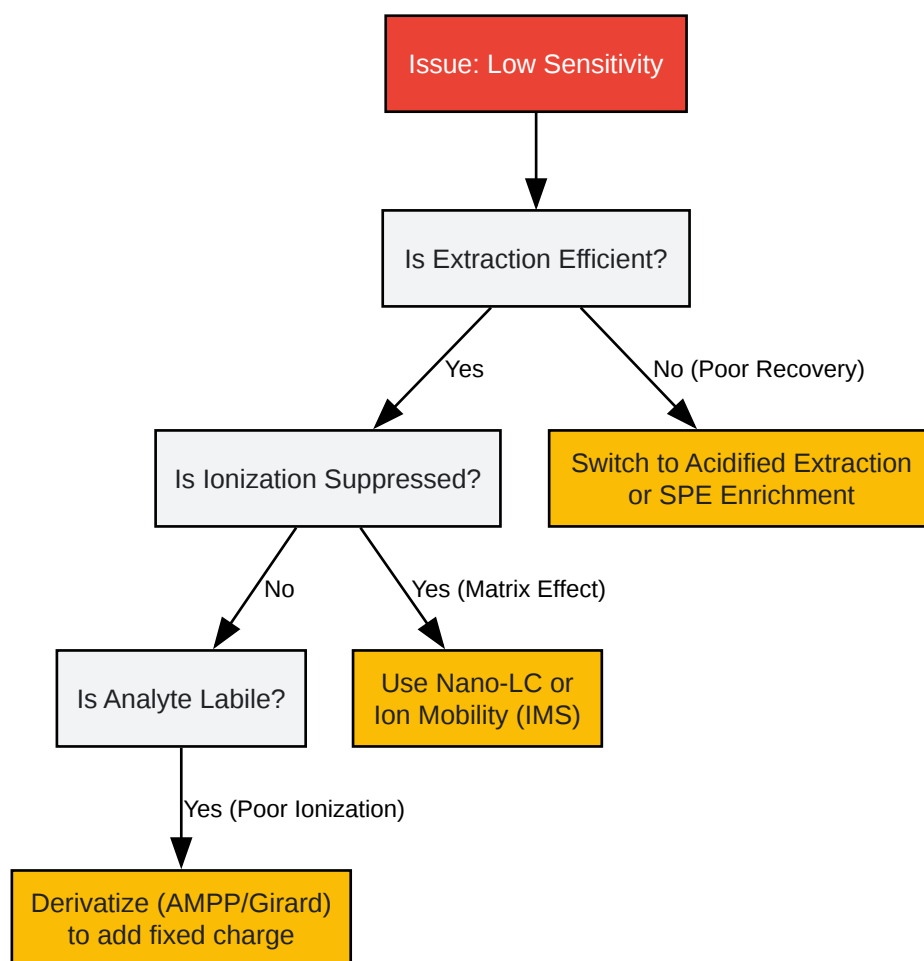

[Click to download full resolution via product page](#)

References

- Li, H., et al. (2021).[1] "Chemical derivatization strategy for mass spectrometry-based lipidomics." Mass Spectrometry Reviews. [Link](#)
- Han, X., & Gross, R. W. (2005).[2] "Shotgun lipidomics: electrospray ionization mass spectrometric analysis and quantitation of cellular lipidomes directly from crude extracts of biological samples." Mass Spectrometry Reviews. [Link](#)
- Ma, X., et al. (2016). "Paternò-Büchi reaction for localization of double bonds in lipids." Analytica Chimica Acta. [Link](#)
- Cajka, T., & Fiehn, O. (2014). "Comprehensive analysis of lipids in biological systems by liquid chromatography-mass spectrometry." Trends in Analytical Chemistry. [Link](#)

- Paglia, G., et al. (2015). "Ion mobility mass spectrometry in the analysis of lipids." Analytical Chemistry. [Link](#)
- BenchChem Technical Support. (2025). "Quantification of Low-Abundance Lipid Mediators." [Link](#)

Need Custom Synthesis?

BenchChem offers custom synthesis for rare earth carbides and specific isotopic labeling.

Email: info@benchchem.com or [Request Quote Online](#).

Sources

- 1. pubs.acs.org [pubs.acs.org]
- 2. [Frontiers | Integrating the potential of ion mobility spectrometry-mass spectrometry in the separation and structural characterisation of lipid isomers](#) [frontiersin.org]
- To cite this document: BenchChem. [Enhancing detection sensitivity of low-abundance lipids]. BenchChem, [2026]. [Online PDF]. Available at: [<https://www.benchchem.com/product/b564529/docs#enhancing-detection-sensitivity-of-low-abundance-lipids>]

Disclaimer & Data Validity:

The information provided in this document is for Research Use Only (RUO) and is strictly not intended for diagnostic or therapeutic procedures. While BenchChem strives to provide accurate protocols, we make no warranties, express or implied, regarding the fitness of this product for every specific experimental setup.

Technical Support: The protocols provided are for reference purposes. Unsure if this reagent suits your experiment?

Need Industrial/Bulk Grade? [Request Custom Synthesis Quote](#)

BenchChem

Our mission is to be the trusted global source of essential and advanced chemicals, empowering scientists and researchers to drive progress in science and industry.

Contact

Address: 3281 E Guasti Rd

Ontario, CA 91761, United States

Phone: (601) 213-4426

Email: info@benchchem.com

[Contact our Ph.D. Support Team for a compatibility check](#)