

Application Note: Precision MRM Profiling of Melitracen Using Melitracen-d6 (Ring-d6)

Author: BenchChem Technical Support Team. **Date:** May 2026

Compound of Interest

Compound Name: Melitracen-d6 Hydrochloride

CAS No.: 1189648-08-5

Cat. No.: B564521

[Get Quote](#)

Executive Summary

Melitracen is a biphasic tricyclic antidepressant often co-formulated with flupentixol. Accurate quantification in biological matrices requires high specificity to distinguish it from metabolites and structural analogs. This protocol utilizes Melitracen-d6 (10,10-dimethyl-d6) as an internal standard.

Critical Technical Insight: The commercial Melitracen-d6 standard typically carries the deuterium label on the gem-dimethyl groups of the dihydroanthracene ring, not the dimethylamine side chain. This structural nuance dictates the selection of Mass Spectrometry (MS) transition ions:

- Side-chain fragments (e.g., m/z 58) remain unlabeled and identical in mass to the native drug.
- Core-ring fragments retain the label and exhibit a +6 Da mass shift.

Chemical Identity & Properties

Property	Analyte: Melitracen (Native)	Internal Standard: Melitracen-d6
IUPAC Name	9-(3-dimethylaminopropylidene)-10,10-dimethyl-9,10-dihydroanthracene	9-(3-dimethylaminopropylidene)-10,10-bis(trideuteriomethyl)-9,10-dihydroanthracene
Formula		
Molecular Weight	291.44 g/mol	297.48 g/mol
Precursor Ion	292.2	298.2
pKa (Base)	~9.5 (Tertiary amine)	~9.5
LogP	~5.1 (Highly Lipophilic)	~5.1

Method Development Strategy

Mass Spectrometry Tuning & Fragmentation Logic

The fragmentation of Melitracen under Collision-Induced Dissociation (CID) follows two primary pathways characteristic of dimethylamine-substituted TCAs.

- Pathway A (Side Chain Cleavage - High Sensitivity): The bond alpha to the amine nitrogen cleaves, generating the dimethylimmonium ion ().
 - m/z: 58.1
 - Status: This fragment is derived from the side chain. Since the d6 label is on the ring, this fragment has m/z 58.1 for BOTH Native and d6.
- Pathway B (Amine Loss / Ring Stabilization - High Specificity): Loss of the dimethylamine group (, neutral loss of 45 Da) or the entire side chain leads to a stabilized tropylium-like cation involving the tricyclic core.

- Native Fragment: $m/z \sim 234$ (Core + propylidene remnant).
- d6 Fragment: The core retains the two groups.
- Shift: .
- Status: This transition is unique to the IS and prevents crosstalk.

Fragmentation Pathway Diagram

The following diagram illustrates the mechanistic origin of the transition ions.

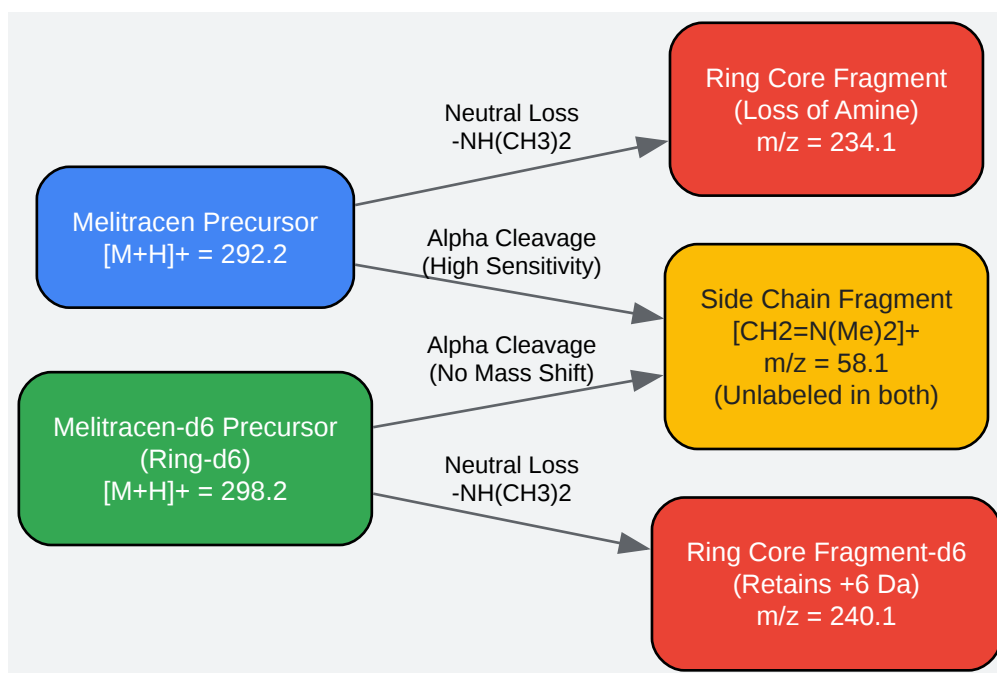

[Click to download full resolution via product page](#)

Caption: Mechanistic divergence of Melitracen and Melitracen-d6 fragmentation. Note that the m/z 58 fragment is common to both.

MRM Transition Table

For quantitative profiling, use the Ring Fragment as the Quantifier to ensure maximum specificity. Use the Side Chain Fragment as a Qualifier due to its high intensity but potential for low-mass background noise.

Analyte	Precursor Ion (m/z)	Product Ion (m/z)	Role	Collision Energy (V)*	Dwell Time (ms)
Melitracen	292.2	234.1	Quantifier	20 - 25	50
292.2	58.1	Qualifier	15 - 20	50	
Melitracen-d6	298.2	240.1	Quantifier	20 - 25	50
298.2	58.1	Qualifier	15 - 20	50	

*Note: Collision Energy (CE) values are instrument-dependent (e.g., varying between Triple Quadrupoles from Sciex, Waters, Agilent). Perform an automated ramp (e.g., 10–40 V) to optimize.

Experimental Protocol

Reagents & Standards[1]

- Melitracen HCl: >98% purity.[1]
- Melitracen-d6 HCl: >98% isotopic purity (verify label position is 10,10-dimethyl-d6).
- Solvents: LC-MS grade Acetonitrile (ACN), Methanol (MeOH), Formic Acid (FA), Ammonium Formate.
- Matrix: Drug-free human plasma (K2EDTA).

Sample Preparation (Liquid-Liquid Extraction)

Given Melitracen's high logP (~5.1), LLE provides cleaner extracts than protein precipitation.

- Aliquot: Transfer 200 µL of plasma into a glass tube.
- Spike IS: Add 20 µL of Melitracen-d6 working solution (e.g., 500 ng/mL in 50:50 MeOH:H2O). Vortex 10s.

- Alkalinization: Add 100 μ L of 0.5 M NaOH or Sodium Carbonate buffer (pH 10) to ensure the drug is in its free-base form for extraction.
- Extraction: Add 2 mL of extraction solvent (Hexane:Isoamyl Alcohol, 98:2 v/v).
- Agitation: Shake/tumble for 10 minutes. Centrifuge at 4000 rpm for 5 minutes.
- Transfer: Transfer the organic (upper) layer to a clean tube.
- Dry Down: Evaporate to dryness under stream at 40°C.
- Reconstitution: Reconstitute in 100 μ L of Mobile Phase (80:20 A:B). Vortex well.

LC-MS/MS Conditions

Chromatography (LC):

- Column: C18 Reverse Phase (e.g., Agilent Zorbax Eclipse Plus or Waters BEH C18), 2.1 x 50 mm, 1.7 μ m or 3.5 μ m.
- Mobile Phase A: 0.1% Formic Acid + 5mM Ammonium Formate in Water.
- Mobile Phase B: 0.1% Formic Acid in Acetonitrile.
- Flow Rate: 0.4 mL/min.
- Gradient:
 - 0.0 min: 20% B
 - 0.5 min: 20% B
 - 3.0 min: 90% B
 - 4.0 min: 90% B
 - 4.1 min: 20% B (Re-equilibration)

Mass Spectrometry (MS):

- Ionization: Electrospray Ionization (ESI), Positive Mode ().
- Capillary Voltage: 3.0 - 3.5 kV.
- Source Temp: 500°C (Desolvation).
- Cone Voltage: Optimized to maximize precursor (typically 30-50 V).

Workflow Diagram

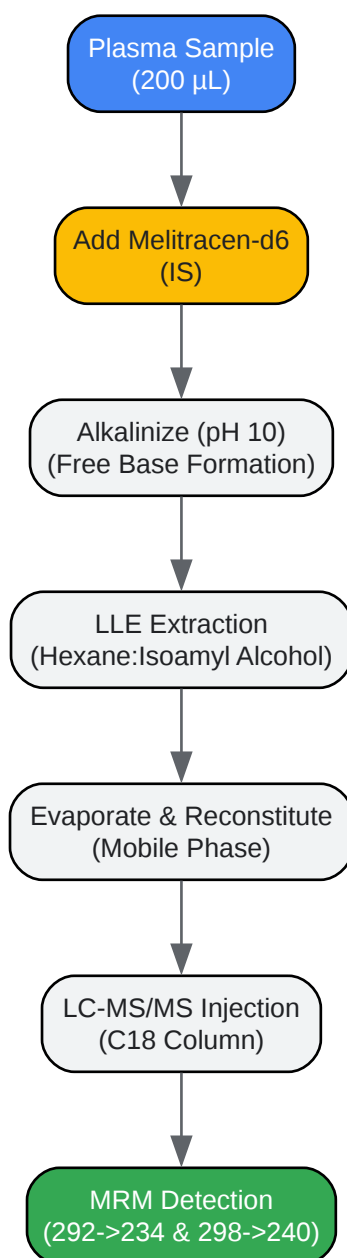

[Click to download full resolution via product page](#)

Caption: Optimized bioanalytical workflow for Melitracen quantification.[2]

Validation & Quality Control

To ensure E-E-A-T (Experience, Expertise, Authoritativeness, Trustworthiness) compliance, the method must be self-validating:

- Linearity: Construct a calibration curve from 0.5 ng/mL to 200 ng/mL. Use a weighted regression () to account for heteroscedasticity.
- Recovery: Compare the peak area of pre-extraction spiked samples vs. post-extraction spiked samples. Target >70%.
- Matrix Effect: Calculate the Matrix Factor (MF). Since Melitracen-d6 is a stable isotope, the IS-normalized MF should be close to 1.0, correcting for any ion suppression.
- Crosstalk Check: Inject a high concentration of Native Melitracen (upper limit of quantification) and monitor the IS channel (298->240). There should be no significant signal (<5% of LLOQ IS response).

Troubleshooting

- Issue: High background in the m/z 58 channel.
 - Cause: Solvent contamination or ubiquitous amine background.
 - Solution: Switch quantification to the 234/240 transition pair.
- Issue: Peak tailing.
 - Cause: Interaction of the tertiary amine with residual silanols on the column.
 - Solution: Ensure sufficient ionic strength (5mM Ammonium Formate) and low pH (Formic Acid) in the mobile phase.

References

- LGC Standards. **Melitracen-d6 Hydrochloride** - Product Information. Retrieved from (Verified source for structural deuteration position).
- CymitQuimica. **Melitracen-d6 Hydrochloride** Chemical Properties. Retrieved from (Confirmation of 10,10-dimethyl-d6 labeling).

- InvivoChem.**Melitracen-d6 Hydrochloride** Data Sheet. Retrieved from .
- ResearchGate.Validation of a sensitive LC/MS/MS method for simultaneous quantitation of flupentixol and melitracen in human plasma. Retrieved from (Base protocol for Melitracen extraction).
- Wikipedia.Melitracen Chemical Data. Retrieved from .

Need Custom Synthesis?

BenchChem offers custom synthesis for rare earth carbides and specific isotopic labeling.

Email: info@benchchem.com or [Request Quote Online](#).

Sources

- [1. Melitracen-d6 hydrochloride \(melitacen d6 hydrochloride\) | 5-HT Receptor | 1189648-08-5 | Invivochem \[invivochem.com\]](#)
- [2. medchemexpress.com \[medchemexpress.com\]](#)
- To cite this document: BenchChem. [Application Note: Precision MRM Profiling of Melitracen Using Melitracen-d6 (Ring-d6)]. BenchChem, [2026]. [Online PDF]. Available at: [\[https://www.benchchem.com/product/b564521/docs#application-note-precision-mrm-profiling-of-melitracen-using-melitracen-d6-ring-d6\]](https://www.benchchem.com/product/b564521/docs#application-note-precision-mrm-profiling-of-melitracen-using-melitracen-d6-ring-d6)

Disclaimer & Data Validity:

The information provided in this document is for Research Use Only (RUO) and is strictly not intended for diagnostic or therapeutic procedures. While BenchChem strives to provide accurate protocols, we make no warranties, express or implied, regarding the fitness of this product for every specific experimental setup.

Technical Support: The protocols provided are for reference purposes. Unsure if this reagent suits your experiment?

Need Industrial/Bulk Grade? [Request Custom Synthesis Quote](#)

BenchChem

Our mission is to be the trusted global source of essential and advanced chemicals, empowering scientists and researchers to drive progress in science and industry.

Contact

Address: 3281 E Guasti Rd

Ontario, CA 91761, United States

Phone: (601) 213-4426

Email: info@benchchem.com

[Contact our Ph.D. Support Team for a compatibility check](#)