

# Advanced Exploratory Frameworks for Synthetic Hydroxyproline Derivatives

**Author:** BenchChem Technical Support Team. **Date:** May 2026

## Compound of Interest

Compound Name: *Mth-DL-hydroxy proline*

CAS No.: 104809-12-3

Cat. No.: B564125

[Get Quote](#)

## Introduction: The Chiral Scaffold of Choice

Hydroxyproline (Hyp), specifically (2S,4R)-4-hydroxyproline, is more than a collagen constituent; it is a privileged chiral scaffold in modern drug discovery and asymmetric synthesis. Its rigid pyrrolidine ring, coupled with two stereocenters and orthogonal functional groups (amine, carboxyl, hydroxyl), allows for precise spatial positioning of pharmacophores.

For researchers, the value of Hyp derivatives lies in their conformational tunability. Unlike flexible amino acids, Hyp derivatives can be "locked" into specific ring puckers (C4-exo vs. C4-endo).[1] This guide explores the synthetic manipulation of these derivatives, focusing on how stereoelectronic effects dictate their utility in peptidomimetics, targeted protein degradation (PROTACs), and organocatalysis.

## Mechanistic Core: Stereoelectronic Control of Ring Pucker

The utility of Hyp derivatives is grounded in the ability to control the pyrrolidine ring conformation. The ring exists in dynamic equilibrium between two envelope conformations:

- C4-exo (Up): The C4 carbon is displaced to the same side as the carboxylate.
- C4-endo (Down): The C4 carbon is displaced to the opposite side.

## The Gauche Effect and $n \rightarrow \pi^*$ Interactions

The preference for one pucker over the other is driven by the electronegativity of the substituent at C4 and its stereochemistry.

- Electron-withdrawing groups (EWG) at 4R (trans): Induce a C4-exo pucker due to the gauche effect (maximization of orbital overlap between  $\sigma_{C-C}$  and  $\sigma_{C-O}$  orbitals) and  $n \rightarrow \pi^*$  interactions between the amide oxygen and the carbonyl carbon.
- Electron-withdrawing groups at 4S (cis): Induce a C4-endo pucker.

This control is critical in drug design. For instance, VHL E3 ligase ligands (used in PROTACs) strictly require the C4-exo conformation for binding, making the (4R)-stereochemistry non-negotiable.

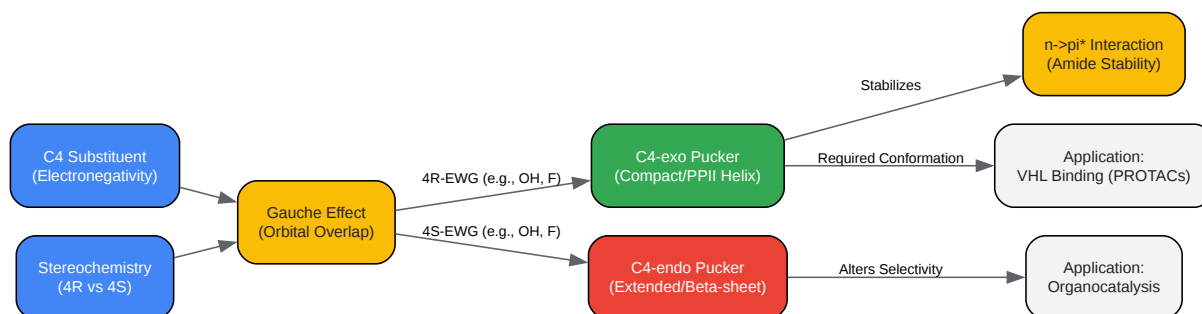

[Click to download full resolution via product page](#)

Figure 1: Stereoelectronic logic governing pyrrolidine ring pucker and downstream applications.

## Synthetic Strategies and Functionalization

Exploratory studies often require accessing non-natural isomers (e.g., cis-Hyp) or functionalized analogues (e.g., 4-fluoroproline).

### The Divergent Pathway

Starting from commercially available trans-4-hydroxy-L-proline, synthesis diverges based on the target:

- N-Protection: Essential first step. Boc or Cbz groups are preferred to prevent diketopiperazine formation during coupling.
- C4-Inversion (The Mitsunobu Route): To access cis-derivatives (4S), the configuration at C4 must be inverted. The Mitsunobu reaction is the gold standard here, using benzoic acid as the nucleophile followed by hydrolysis.
- C4-Fluorination: Replaces -OH with -F to enhance metabolic stability and tune pucker without hydrogen bonding potential. (DAST or Deoxo-Fluor reagents are standard).

### Quantitative Comparison of Derivatives

The following table summarizes the structural impact of common C4 modifications.

Derivative	Config	Ring Pucker Pref.	(Amide)	Key Application
Hyp (Natural)	(2S, 4R)	C4-exo (Strong)	High (Trans favored)	Collagen mimetics, VHL ligands
cis-Hyp	(2S, 4S)	C4-endo	Low (Cis favored)	Beta-turn mimetics, novel scaffolds
4R-Fluoroproline	(2S, 4R)	C4-exo (Very Strong)	Very High	Hyperstable collagen, high-affinity VHL
4S-Fluoroproline	(2S, 4S)	C4-endo (Very Strong)	Very Low	Destabilizing probes, conformational switches
4-Oxoproline	N/A	Planar/Flexible	Intermediate	Reactive intermediate for reductive amination

## Experimental Protocol: Stereoinversion to cis-4-Hydroxyproline

Objective: Synthesis of N-Boc-cis-4-hydroxy-L-proline methyl ester from N-Boc-trans-4-hydroxy-L-proline methyl ester via Mitsunobu inversion. Rationale: This protocol is chosen because accessing the cis (4S) isomer is a common bottleneck in exploratory medicinal chemistry. It demonstrates the manipulation of stereocenters critical for structure-activity relationship (SAR) studies.

### Reagents & Equipment[3][4]

- Substrate: N-Boc-trans-4-hydroxy-L-proline methyl ester (1.0 equiv)
- Reagents: Triphenylphosphine (

, 1.2 equiv), Diisopropyl azodicarboxylate (DIAD, 1.2 equiv), Benzoic acid (1.2 equiv).

- Solvent: Anhydrous THF (0.1 M concentration).
- Atmosphere: Dry Nitrogen or Argon.

## Step-by-Step Methodology

- Complex Formation:
  - Charge a flame-dried round-bottom flask with  
  
and Benzoic Acid.
  - Dissolve in anhydrous THF and cool to 0°C.
  - Critical Step: Add DIAD dropwise over 10 minutes. The solution will turn yellow. Allow the betaine complex to form for 15 minutes. Why? Pre-formation of the betaine prevents side reactions with the alcohol.
- Inversion Reaction:
  - Add the substrate (N-Boc-trans-4-Hyp-OMe) dissolved in minimal THF dropwise to the reaction mixture at 0°C.
  - Allow to warm to room temperature and stir for 12–16 hours.
  - Monitoring: Check via TLC (Hexane:EtOAc 3:1). The product (benzoate ester) usually runs higher than the starting alcohol.
- Hydrolysis (Unmasking the Alcohol):
  - Concentrate the reaction mixture. Redissolve the crude benzoate intermediate in Methanol.
  - Add  
  
(0.1 equiv) or NaOMe (1.1 equiv) and stir at room temperature for 2 hours.

- Note: Mild basic conditions preserve the methyl ester and Boc group while cleaving the benzoate.
- Purification:
  - Neutralize with dilute HCl (to pH 7).
  - Extract with EtOAc, wash with brine, dry over  
.
  - Purify via flash column chromatography (Silica gel, gradient 10-50% EtOAc in Hexane).

#### Validation Criteria:

- <sup>1</sup>H NMR: Look for the C4-H signal. In the trans isomer, it appears as a multiplet around 4.5 ppm. In the cis isomer, the signal often shifts and the coupling constants ( ) change due to the altered ring pucker (check and ).
- Optical Rotation: The specific rotation should invert sign or significantly change magnitude compared to the starting material.

## Applications in Drug Discovery: The VHL Paradigm

The most high-impact application of synthetic Hyp derivatives today is in Targeted Protein Degradation (TPD).

The Von Hippel-Lindau (VHL) E3 ubiquitin ligase naturally recognizes a hydroxylated proline residue on HIF-1

. Synthetic ligands for VHL mimic this interaction.

- The Anchor: The (2S,4R)-4-hydroxyproline core is the "anchor" that binds to the VHL protein.

- The Vector: The C4-hydroxyl group is often the attachment point for the linker that connects to the target protein ligand.
- Optimization: Replacing the C4-OH with C4-amino or C4-fluoro groups (with specific stereochemistry) allows researchers to tune the binding affinity and permeability of PROTACs.

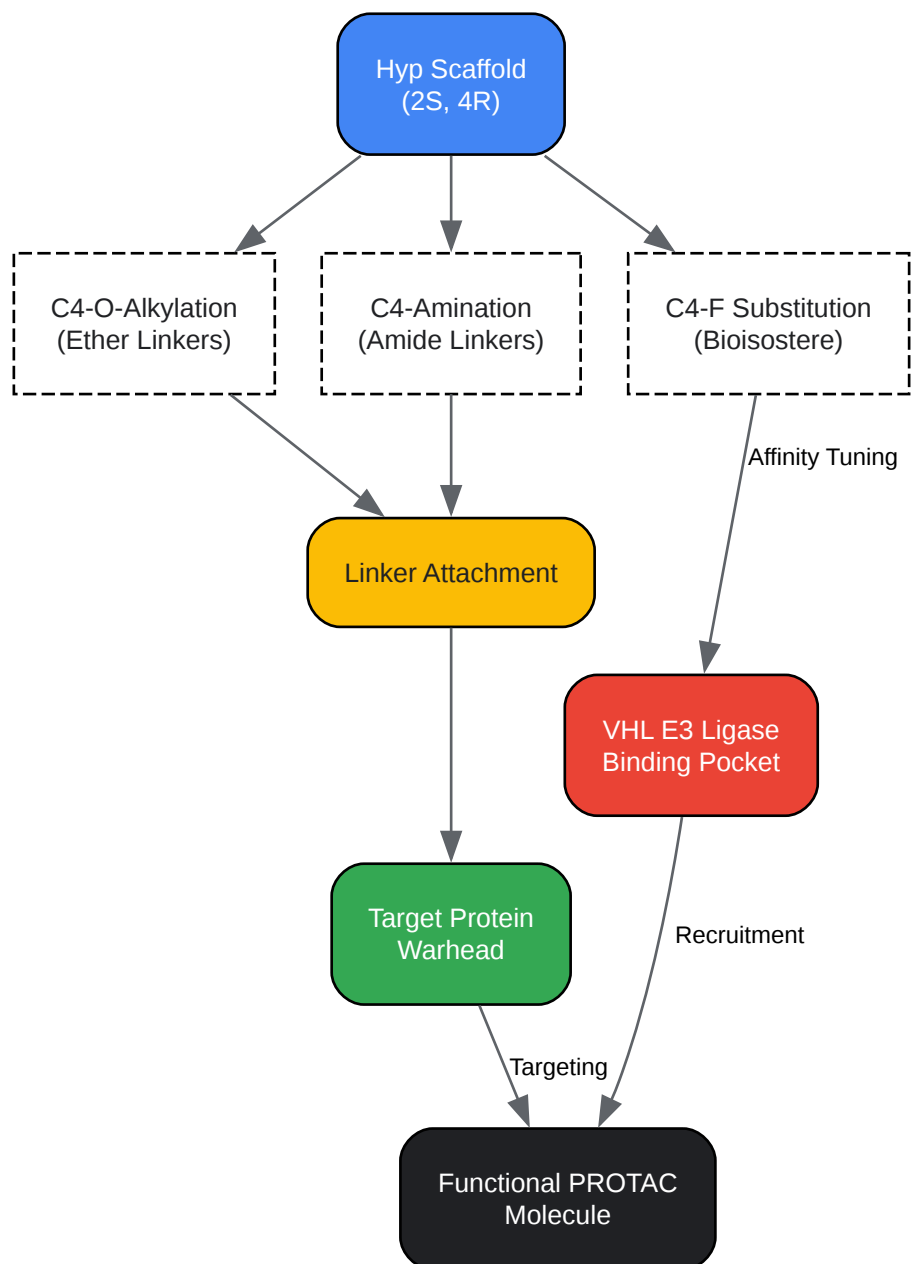

[Click to download full resolution via product page](#)

Figure 2: Workflow for integrating Hyp derivatives into PROTAC design for targeted protein degradation.

## Future Outlook

The field is moving beyond simple substitution. Emerging trends include:

- **Multicomponent Reactions:** Using 4-oxoproline in Ugi or Passerini reactions to generate highly substituted libraries.
- **Organocatalyst Immobilization:** Using the C4-hydroxyl as a handle to tether proline catalysts to polymers or magnetic nanoparticles for recycling.
- **Bio-orthogonal Chemistry:** Introducing azides or alkynes at C4 to allow "click" chemistry labeling of collagen in live cells.

## References

- Testa, A., et al. (2018). "3-Fluoro-4-hydroxyprolines: Synthesis, Conformational Analysis, and Stereoselective Recognition by the VHL E3 Ubiquitin Ligase for Targeted Protein Degradation." *Journal of the American Chemical Society*.<sup>[2]</sup> [Link](#)
- Raines, R. T. (2016). "4-Fluoroproline: Conformational Analysis and Effects on the Stability and Folding of Peptides and Proteins." Raines Lab Publications. [Link](#)
- Zlotin, S. G. (2015).<sup>[3]</sup> "Hydroxyproline Derivatives as Asymmetric Organocatalysts." *Sustainable Catalysis*. [Link](#)
- Smith, J. A., et al. (2011). "Simple Synthesis of cis-4-Hydroxy-L-Proline and Derivatives Suitable for Use as Intermediates in Peptide Synthesis." *ResearchGate*. [Link](#)
- BenchChem. (2025). "Technical Guide: Synthesis of N-Boc-D-proline and Derivatives." *BenchChem Technical Guides*. [Link](#)
- ChemicalBook. (2026). "N-Boc-trans-4-Hydroxy-L-proline methyl ester Properties and Synthesis." *ChemicalBook Database*. [Link](#)

**Need Custom Synthesis?**

BenchChem offers custom synthesis for rare earth carbides and specific isotopic labeling.

Email: [info@benchchem.com](mailto:info@benchchem.com) or [Request Quote Online](#).

## Sources

- 1. 3-Fluoro-4-hydroxyprolines: Synthesis, Conformational Analysis, and Stereoselective Recognition by the VHL E3 Ubiquitin Ligase for Targeted Protein Degradation - PubMed [[pubmed.ncbi.nlm.nih.gov](https://pubmed.ncbi.nlm.nih.gov)]
- 2. [kvinzo.com](https://kvinzo.com) [[kvinzo.com](https://kvinzo.com)]
- 3. [books.rsc.org](https://books.rsc.org) [[books.rsc.org](https://books.rsc.org)]
- To cite this document: BenchChem. [Advanced Exploratory Frameworks for Synthetic Hydroxyproline Derivatives]. BenchChem, [2026]. [Online PDF]. Available at: [<https://www.benchchem.com/product/b564125/docs#advanced-exploratory-frameworks-for-synthetic-hydroxyproline-derivatives>]

---

**Disclaimer & Data Validity:**

The information provided in this document is for Research Use Only (RUO) and is strictly not intended for diagnostic or therapeutic procedures. While BenchChem strives to provide accurate protocols, we make no warranties, express or implied, regarding the fitness of this product for every specific experimental setup.

**Technical Support:** The protocols provided are for reference purposes. Unsure if this reagent suits your experiment?

**Need Industrial/Bulk Grade?** [Request Custom Synthesis Quote](#)

# BenchChem

Our mission is to be the trusted global source of essential and advanced chemicals, empowering scientists and researchers to drive progress in science and industry.

## Contact

Address: 3281 E Guasti Rd

Ontario, CA 91761, United States

Phone: (601) 213-4426

Email: [info@benchchem.com](mailto:info@benchchem.com)

[Contact our Ph.D. Support Team for a compatibility check](#)