

Application Note: Comprehensive NMR Characterization of Ethyl (5-ethyl-2-pyridinyl)acetate

Author: BenchChem Technical Support Team. **Date:** May 2026

Compound of Interest

Compound Name: Ethyl (5-ethyl-2-pyridinyl)acetate

CAS No.: 99986-02-4

Cat. No.: B563064

[Get Quote](#)

Abstract

This application note provides a detailed protocol for the complete Nuclear Magnetic Resonance (NMR) characterization of **Ethyl (5-ethyl-2-pyridinyl)acetate** (CAS 99986-02-4), a key intermediate in organic synthesis.[1] The structural elucidation of this molecule is accomplished through a combination of one-dimensional (^1H and ^{13}C) and two-dimensional (COSY, HSQC, HMBC) NMR experiments. This guide is intended for researchers, scientists, and professionals in drug development, offering a robust methodology for the unambiguous assignment of all proton and carbon resonances, thereby ensuring structural integrity and purity assessment.

Introduction

Ethyl (5-ethyl-2-pyridinyl)acetate is a disubstituted pyridine derivative with applications in the synthesis of more complex molecules.[1] Accurate structural verification is a critical step in any synthetic workflow to ensure the desired compound has been obtained and is of sufficient purity for subsequent steps. NMR spectroscopy is the most powerful technique for the non-

destructive analysis of molecular structures in solution. This document outlines the systematic approach to characterizing this compound using a standard 400 MHz NMR spectrometer.

The structure of **Ethyl (5-ethyl-2-pyridinyl)acetate** presents several distinct spin systems that can be resolved and assigned using a suite of NMR experiments. The ethyl group on the pyridine ring, the ethyl ester moiety, and the aromatic protons of the pyridine ring all provide unique signatures that will be analyzed in detail.

Predicted NMR Data

Due to the absence of a publicly available, experimentally verified spectrum for **Ethyl (5-ethyl-2-pyridinyl)acetate**, the following data has been generated using validated NMR prediction software and cross-referenced with known chemical shifts for analogous structures, such as ethylbenzene and ethyl acetate.^{[2][3][4]}

¹H NMR (400 MHz, CDCl₃) Predicted Data

Peak	Chemical Shift (δ, ppm)	Multiplicity	Integration	Coupling Constant (J, Hz)	Assignment
1	8.35	d	1H	2.2	H-6
2	7.55	dd	1H	8.0, 2.3	H-4
3	7.20	d	1H	8.0	H-3
4	4.20	q	2H	7.1	O-CH ₂ -CH ₃
5	3.80	s	2H	-	Py-CH ₂ -CO
6	2.65	q	2H	7.6	Py-CH ₂ -CH ₃
7	1.28	t	3H	7.6	Py-CH ₂ -CH ₃
8	1.25	t	3H	7.1	O-CH ₂ -CH ₃

¹³C NMR (100 MHz, CDCl₃) Predicted Data

Peak	Chemical Shift (δ , ppm)	Assignment
1	171.5	C=O
2	155.0	C-2
3	148.5	C-6
4	137.0	C-4
5	135.0	C-5
6	123.0	C-3
7	61.0	O-CH ₂ -CH ₃
8	42.0	Py-CH ₂ -CO
9	25.5	Py-CH ₂ -CH ₃
10	15.0	Py-CH ₂ -CH ₃
11	14.2	O-CH ₂ -CH ₃

Experimental Protocols

Sample Preparation

- Weigh approximately 10-20 mg of **Ethyl (5-ethyl-2-pyridinyl)acetate**.
- Dissolve the sample in approximately 0.6 mL of deuterated chloroform (CDCl₃) containing 0.03% (v/v) tetramethylsilane (TMS) as an internal standard.
- Transfer the solution to a 5 mm NMR tube.

The choice of CDCl₃ as the solvent is based on its ability to dissolve a wide range of organic compounds and its well-characterized residual solvent peak.[5] TMS is used as the internal reference for both ¹H and ¹³C NMR, with its signal set to 0.00 ppm.[6]

NMR Data Acquisition

All NMR spectra should be acquired on a 400 MHz spectrometer equipped with a broadband probe. The following are suggested acquisition parameters, which may require optimization

based on the specific instrument and sample concentration.

¹H NMR Spectroscopy:

- Pulse Program: zg30
- Number of Scans: 16
- Acquisition Time: 4.096 s
- Relaxation Delay: 2.0 s
- Spectral Width: 8278 Hz (20.6 ppm)
- Temperature: 298 K

¹³C NMR Spectroscopy:

- Pulse Program: zgpg30 (proton-decoupled)
- Number of Scans: 1024
- Acquisition Time: 1.305 s
- Relaxation Delay: 2.0 s
- Spectral Width: 24038 Hz (238 ppm)
- Temperature: 298 K

2D NMR Spectroscopy (COSY, HSQC, HMBC):

Standard pulse programs available on the spectrometer software should be used. The spectral widths should be set to encompass all proton and carbon signals. The number of increments in the indirect dimension should be sufficient to achieve good resolution.

Data Processing and Analysis

- Apply a Fourier transform to the acquired Free Induction Decays (FIDs).

- Phase correct the spectra manually.
- Calibrate the ^1H spectrum by setting the TMS peak to 0.00 ppm. Calibrate the ^{13}C spectrum using the TMS signal or the residual solvent peak of CDCl_3 ($\delta = 77.16$ ppm).
- Integrate the signals in the ^1H spectrum.
- Analyze the chemical shifts, multiplicities, and coupling constants to assign the signals to the corresponding nuclei in the molecule.

Spectral Interpretation and Structural Elucidation

The predicted chemical shifts and coupling patterns provide a clear roadmap for the structural assignment of **Ethyl (5-ethyl-2-pyridinyl)acetate**.

^1H NMR Spectrum Analysis

- Aromatic Region (δ 7.0-8.5 ppm): Three signals are expected for the pyridine ring protons. The proton at the 6-position (H-6) is expected to be the most downfield due to its proximity to the nitrogen atom and will appear as a doublet. The H-4 proton will be a doublet of doublets due to coupling with both H-3 and H-6 (meta-coupling). The H-3 proton will appear as a doublet, coupled to H-4.
- Ethyl Ester Group (δ 4.2 and 1.25 ppm): The methylene protons ($-\text{O}-\text{CH}_2-\text{CH}_3$) are expected around 4.2 ppm as a quartet, coupled to the adjacent methyl group. The methyl protons ($-\text{O}-\text{CH}_2-\text{CH}_3$) will appear as a triplet around 1.25 ppm.
- Methylene Bridge (δ 3.80 ppm): The methylene protons between the pyridine ring and the carbonyl group ($\text{Py}-\text{CH}_2-\text{CO}$) are expected to be a singlet around 3.80 ppm as they have no adjacent protons to couple with.
- Ethyl Group on Pyridine (δ 2.65 and 1.28 ppm): The methylene protons ($\text{Py}-\text{CH}_2-\text{CH}_3$) will be a quartet around 2.65 ppm, and the methyl protons ($\text{Py}-\text{CH}_2-\text{CH}_3$) will be a triplet around 1.28 ppm.

^{13}C NMR Spectrum Analysis

The proton-decoupled ^{13}C NMR spectrum is predicted to show 11 distinct signals, corresponding to the 11 unique carbon atoms in the molecule.

- Carbonyl Carbon (δ 171.5 ppm): The ester carbonyl carbon is the most downfield signal.
- Aromatic Carbons (δ 123.0-155.0 ppm): Five signals are expected for the pyridine ring carbons. The carbons attached to the nitrogen (C-2 and C-6) will be the most downfield in this region.
- Aliphatic Carbons (δ 14.2-61.0 ppm): The remaining five signals correspond to the ethyl ester and ethyl substituent carbons, as well as the methylene bridge. The carbon of the O-CH₂ group will be around 61.0 ppm, while the other aliphatic carbons will be further upfield.

2D NMR for Unambiguous Assignments

- COSY (Correlation Spectroscopy): This experiment will confirm the coupling relationships between adjacent protons. For example, correlations are expected between the protons of the ethyl groups (CH₂ and CH₃) and between the coupled protons on the pyridine ring.
- HSQC (Heteronuclear Single Quantum Coherence): This experiment correlates each proton with the carbon to which it is directly attached, allowing for the definitive assignment of the carbon signals based on the already assigned proton spectrum.
- HMBC (Heteronuclear Multiple Bond Correlation): This experiment shows correlations between protons and carbons that are two or three bonds away. This is particularly useful for identifying quaternary carbons and for confirming the connectivity of the different fragments of the molecule. For instance, a correlation between the methylene bridge protons (Py-CH₂-CO) and the carbonyl carbon, as well as carbons in the pyridine ring, would confirm the overall structure.

Visualizations

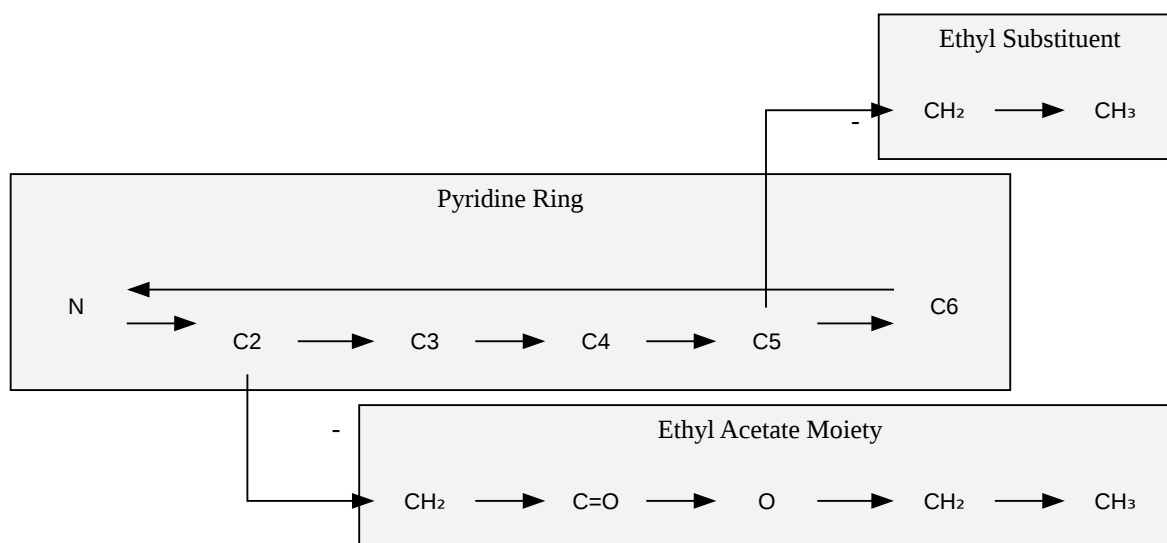

[Click to download full resolution via product page](#)

Caption: Molecular structure of **Ethyl (5-ethyl-2-pyridinyl)acetate**.

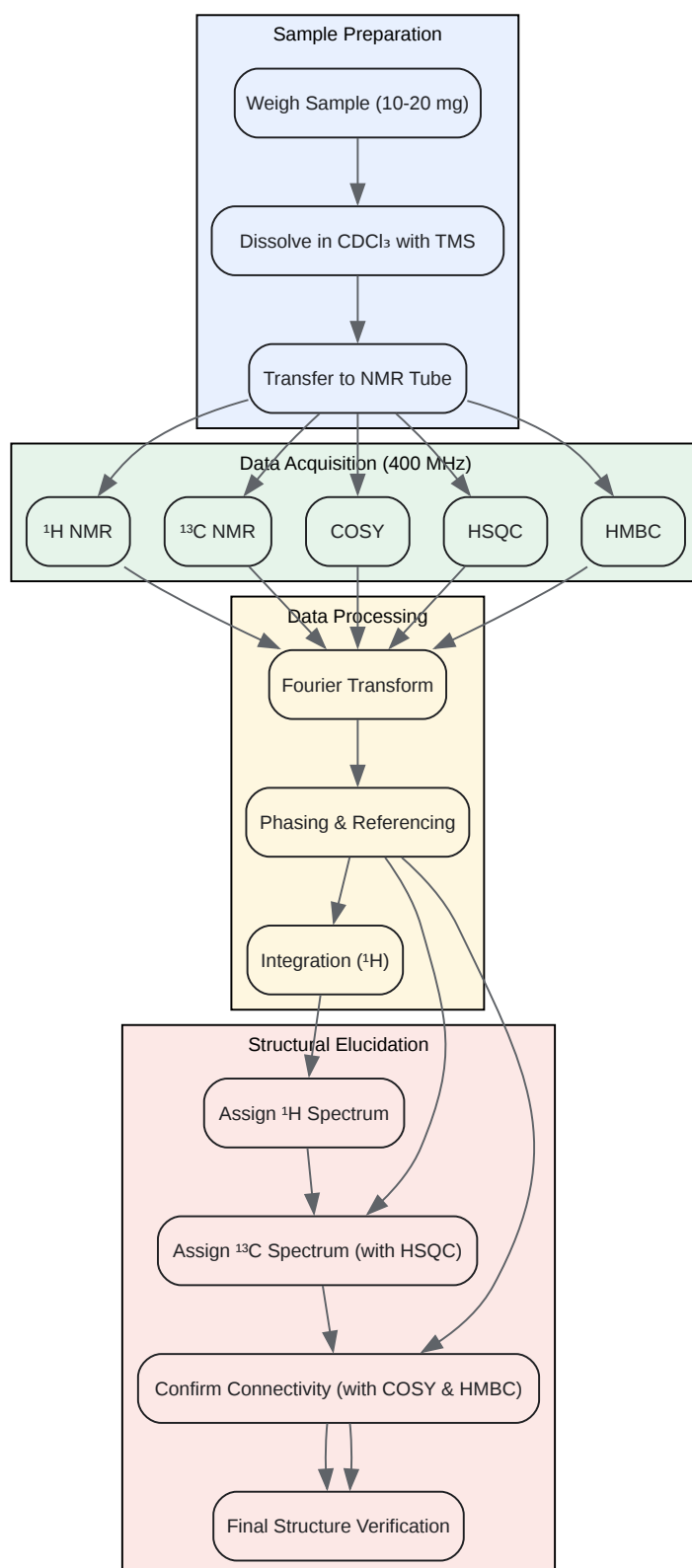

[Click to download full resolution via product page](#)

Caption: Workflow for NMR characterization.

Conclusion

The combination of one-dimensional and two-dimensional NMR techniques provides a comprehensive and unambiguous characterization of **Ethyl (5-ethyl-2-pyridinyl)acetate**. The protocols and predicted data presented in this application note serve as a valuable guide for researchers to verify the structure and purity of this compound, ensuring the reliability of subsequent synthetic applications. The systematic approach detailed herein is broadly applicable to the structural elucidation of other small organic molecules.

References

- Gottlieb, H. E., Kotlyar, V., & Nudelman, A. (1997). NMR Chemical Shifts of Common Laboratory Solvents as Trace Impurities. *The Journal of Organic Chemistry*, 62(21), 7512–7515. [[Link](#)]
- Pharmaffiliates. (n.d.). **Ethyl (5-Ethyl-2-pyridinyl)acetate**. Retrieved January 25, 2026, from [[Link](#)]
- PubChem. (n.d.). Ethyl 2-pyridylacetate. Retrieved January 25, 2026, from [[Link](#)]
- Pohanish, R. P. (Ed.). (2012). *Sittig's Handbook of Toxic and Hazardous Chemicals and Carcinogens*. William Andrew.
- Reich, H. J. (n.d.). *Structure Determination Using Spectroscopic Methods*. University of Wisconsin-Madison. Retrieved January 25, 2026, from [[Link](#)]
- NMRDB.org. (n.d.). Predict 1H proton NMR spectra. Retrieved January 25, 2026, from [[Link](#)]
- PubChem. (n.d.). Ethylbenzene. Retrieved January 25, 2026, from [[Link](#)]
- PubChem. (n.d.). Ethyl Acetate. Retrieved January 25, 2026, from [[Link](#)]
- SpectraBase. (n.d.). 5-Ethyl-2-methylpyridine. Retrieved January 25, 2026, from [[Link](#)]

Need Custom Synthesis?

BenchChem offers custom synthesis for rare earth carbides and specific isotopic labeling.

Email: info@benchchem.com or [Request Quote Online](#).

Sources

- [1. CASPRE \[caspre.ca\]](#)
- [2. Ethylbenzene\(100-41-4\) 1H NMR \[m.chemicalbook.com\]](#)
- [3. C8H10 ethylbenzene low high resolution H-1 proton nmr spectrum of analysis interpretation of chemical shifts ppm spin spin line splitting H1 ethylbenzene 1-H nmr doc brown's advanced organic chemistry revision notes \[docbrown.info\]](#)
- [4. Ethyl acetate\(141-78-6\) 1H NMR spectrum \[chemicalbook.com\]](#)
- [5. Visualizer loader \[nmrdb.org\]](#)
- [6. US5466800A - Process for the preparation of 2,5-disubstituted pyridines - Google Patents \[patents.google.com\]](#)
- [To cite this document: BenchChem. \[Application Note: Comprehensive NMR Characterization of Ethyl \(5-ethyl-2-pyridinyl\)acetate\]. BenchChem, \[2026\]. \[Online PDF\]. Available at: \[https://www.benchchem.com/product/b563064/docs#application-note-comprehensive-nmr-characterization-of-ethyl-5-ethyl-2-pyridinyl-acetate\]](#)

Disclaimer & Data Validity:

The information provided in this document is for Research Use Only (RUO) and is strictly not intended for diagnostic or therapeutic procedures. While BenchChem strives to provide accurate protocols, we make no warranties, express or implied, regarding the fitness of this product for every specific experimental setup.

Technical Support: The protocols provided are for reference purposes. Unsure if this reagent suits your experiment?

Need Industrial/Bulk Grade? [Request Custom Synthesis Quote](#)

BenchChem

Our mission is to be the trusted global source of essential and advanced chemicals, empowering scientists and researchers to drive progress in science and industry.

Contact

Address: 3281 E Guasti Rd

Ontario, CA 91761, United States

Phone: (601) 213-4426

Email: info@benchchem.com

[Contact our Ph.D. Support Team for a compatibility check](#)