

# Technical Support Center: Optimization of ESI Source Parameters for Imidapril-d3

**Author:** BenchChem Technical Support Team. **Date:** April 2026

## Compound of Interest

Compound Name: *Imidapril-d3 Hydrochloride*

CAS No.: *1356017-30-5*

Cat. No.: *B562934*

[Get Quote](#)

Welcome to the technical support center for the analysis of Imidapril-d3. This guide is designed for researchers, scientists, and drug development professionals to provide expert-driven insights and practical, step-by-step solutions for optimizing Electrospray Ionization (ESI) source parameters. As a deuterated internal standard, achieving a stable and robust signal for Imidapril-d3 is critical for the accurate quantification of Imidapril in complex matrices. This document will navigate you through common challenges, offering troubleshooting workflows and validated protocols to enhance the sensitivity, specificity, and reproducibility of your LC-MS/MS analysis.

## Fundamentals: Understanding Imidapril-d3 and the ESI Process

Before troubleshooting, it is essential to understand the analyte and the ionization process.

### Imidapril and Imidapril-d3: Key Chemical Properties

Imidapril is an angiotensin-converting enzyme (ACE) inhibitor and a prodrug that is hydrolyzed in the liver to its active metabolite, imidaprilat.[1] Imidapril-d3 is its stable isotope-labeled

counterpart, making it an ideal internal standard for quantitative bioanalysis.[\[2\]](#)[\[3\]](#)

Property	Imidapril	Imidapril-d3 Hydrochloride
Molecular Formula	C <sub>20</sub> H <sub>27</sub> N <sub>3</sub> O <sub>6</sub>	C <sub>20</sub> H <sub>25</sub> D <sub>3</sub> ClN <sub>3</sub> O <sub>6</sub>
Molecular Weight	405.4 g/mol <a href="#">[1]</a>	444.92 g/mol <a href="#">[4]</a>
Ionization Mode	Primarily Positive ESI ([M+H] <sup>+</sup> )	Primarily Positive ESI ([M+H] <sup>+</sup> )
Key Precursor Ion (m/z)	406	409
Stability Concerns	Susceptible to hydrolysis (forming imidaprilat) and intramolecular cyclization (forming a diketopiperazine derivative), especially at elevated temperatures and humidity. <a href="#">[5]</a> <a href="#">[6]</a> <a href="#">[7]</a> <a href="#">[8]</a> <a href="#">[9]</a>	Similar to Imidapril.

This susceptibility to degradation underscores the importance of carefully optimizing ESI source parameters, particularly temperature, to prevent in-source degradation.

### The Role of Key ESI Source Parameters

The goal of ESI is to efficiently transfer analyte ions from the liquid phase to the gas phase for mass analysis. This is governed by several interdependent parameters:

- **Capillary Voltage:** Applies a high voltage to the incoming liquid, creating a charged spray of droplets. An optimal voltage is needed to maintain a stable spray without causing electrical discharge (corona), which increases noise and reduces signal.[\[10\]](#)
- **Nebulizer Gas:** A high-velocity gas (usually nitrogen) that flows coaxially around the capillary, helping to shear the liquid into fine droplets. Its pressure is critical for efficient droplet formation and desolvation.[\[11\]](#)
- **Drying Gas and Temperature:** A heated gas (also typically nitrogen) that flows through the source to evaporate solvent from the droplets, shrinking them until gas-phase ions are released. These are crucial for the desolvation process.[\[12\]](#)[\[13\]](#)[\[14\]](#)

- Cone (Orifice) Voltage / Declustering Potential: A potential difference between the skimmer and the orifice that helps to prevent solvent clusters from entering the mass analyzer. It can also be used to induce in-source fragmentation for structural confirmation, but excessive voltage will fragment the precursor ion, reducing quantitative signal.[\[10\]](#)

## Troubleshooting Guide: Common Issues and Solutions

This section addresses specific problems in a question-and-answer format, providing systematic workflows to diagnose and resolve them.

### Q1: I am observing a very low or no signal for my Imidapril-d3 standard. Where do I start?

A complete or significant loss of signal is a common but frustrating issue. The cause can range from a simple setup error to a more complex instrument problem. This workflow provides a logical path to identify the root cause.

Potential Causes:

- Incorrect MS tune and method parameters.
- Problems with the LC-MS fluidic path (clogs, leaks).
- Suboptimal ESI source parameters leading to poor ionization efficiency.[\[15\]](#)
- Degradation of the Imidapril-d3 standard.
- Issues with the MS detector or electronics.

Systematic Troubleshooting Workflow

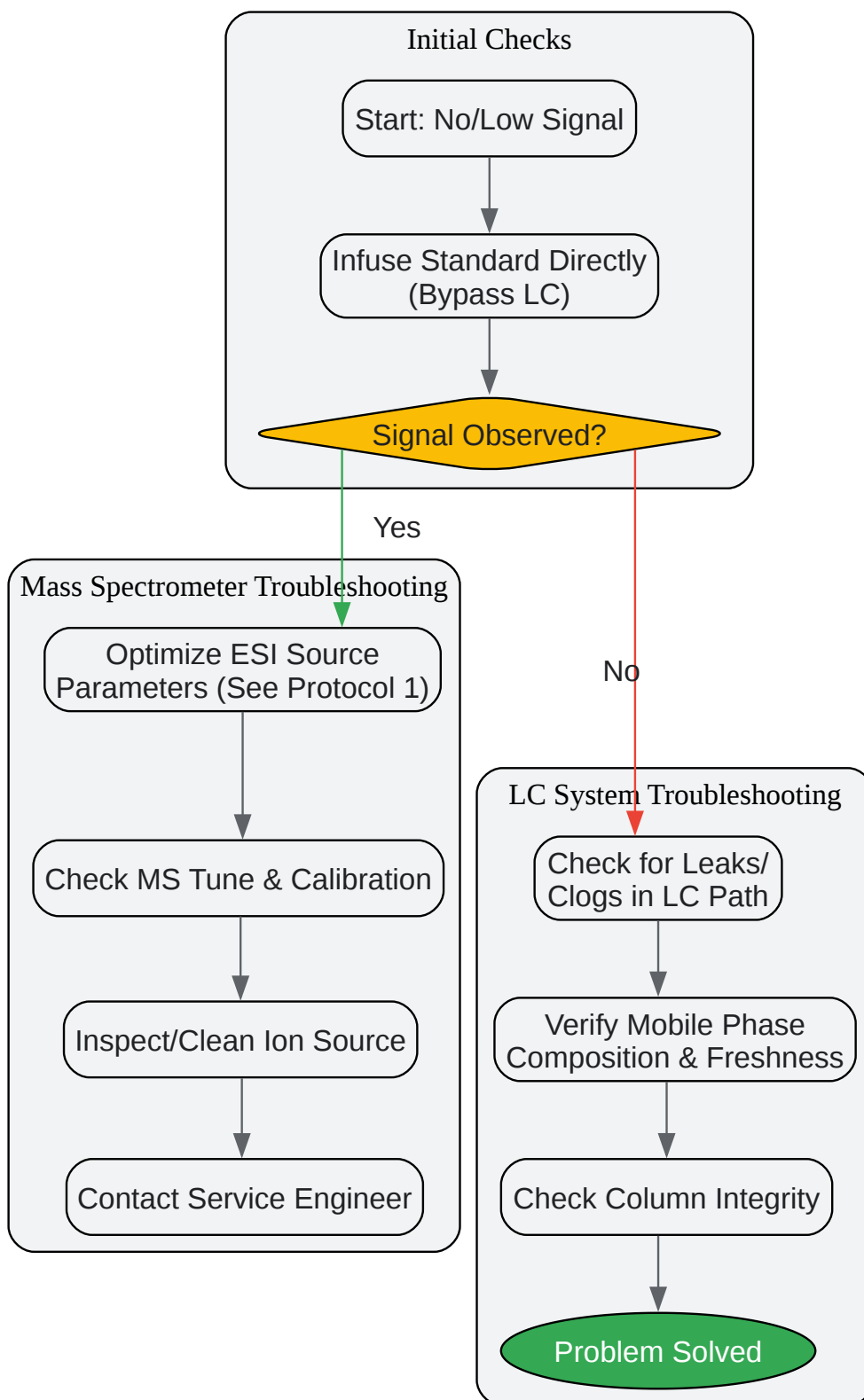

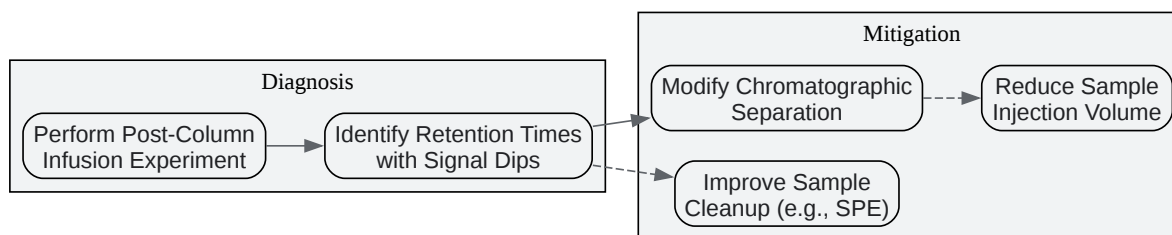

[Click to download full resolution via product page](#)

### Need Custom Synthesis?

BenchChem offers custom synthesis for rare earth carbides and specific isotopic labeling.

Email: [info@benchchem.com](mailto:info@benchchem.com) or [Request Quote Online](#).

## Sources

- [1. Imidapril | C<sub>20</sub>H<sub>27</sub>N<sub>3</sub>O<sub>6</sub> | CID 5464343 - PubChem \[pubchem.ncbi.nlm.nih.gov\]](#)
- [2. medchemexpress.com \[medchemexpress.com\]](#)
- [3. medchemexpress.com \[medchemexpress.com\]](#)
- [4. Imidapril-d<sub>3</sub> Hydrochloride | LGC Standards \[lgcstandards.com\]](#)
- [5. pdf.benchchem.com \[pdf.benchchem.com\]](#)
- [6. Optimization of Storage and Manufacture Conditions for Imidapril Hydrochloride in Solid State as a Way to Reduce Costs of Antihypertensive Therapy - PMC \[pmc.ncbi.nlm.nih.gov\]](#)
- [7. ptfarm.pl \[ptfarm.pl\]](#)
- [8. Is there any association between imidapril hydrochloride stability profile under dry air conditions and cancer initiation? - PubMed \[pubmed.ncbi.nlm.nih.gov\]](#)
- [9. researchgate.net \[researchgate.net\]](#)
- [10. elementlabsolutions.com \[elementlabsolutions.com\]](#)
- [11. Effects of nebulizing and drying gas flow on capillary electrophoresis/mass spectrometry - PubMed \[pubmed.ncbi.nlm.nih.gov\]](#)

- [12. chromatographyonline.com \[chromatographyonline.com\]](#)
- [13. spectroscopyonline.com \[spectroscopyonline.com\]](#)
- [14. chromatographyonline.com \[chromatographyonline.com\]](#)
- [15. gmi-inc.com \[gmi-inc.com\]](#)
- To cite this document: BenchChem. [Technical Support Center: Optimization of ESI Source Parameters for Imidapril-d3]. BenchChem, [2026]. [Online PDF]. Available at: [\[https://www.benchchem.com/product/b562934/docs#technical-support-center-optimization-of-esi-source-parameters-for-imidapril-d3\]](https://www.benchchem.com/product/b562934/docs#technical-support-center-optimization-of-esi-source-parameters-for-imidapril-d3)

---

### Disclaimer & Data Validity:

The information provided in this document is for Research Use Only (RUO) and is strictly not intended for diagnostic or therapeutic procedures. While BenchChem strives to provide accurate protocols, we make no warranties, express or implied, regarding the fitness of this product for every specific experimental setup.

**Technical Support:** The protocols provided are for reference purposes. Unsure if this reagent suits your experiment?

**Need Industrial/Bulk Grade?** [Request Custom Synthesis Quote](#)

## BenchChem

Our mission is to be the trusted global source of essential and advanced chemicals, empowering scientists and researchers to drive progress in science and industry.

### Contact

Address: 3281 E Guasti Rd  
Ontario, CA 91761, United States  
Phone: (601) 213-4426  
Email: [info@benchchem.com](mailto:info@benchchem.com)

[Contact our Ph.D. Support Team for a compatibility check](#)

