

# Technical Monograph: 4-Propylsulfonylacetophenone Derivatives

**Author:** BenchChem Technical Support Team. **Date:** May 2026

## Compound of Interest

	4-
Compound Name:	PROPYLSULFONYLACETOPHE
	NONE
CAS No.:	110031-86-2
Cat. No.:	B562649

[Get Quote](#)

## Design, Synthesis, and Application as Steric Probes in COX-2 Inhibition[1]

### Executive Summary & Pharmacophore Rationale

**4-Propylsulfonylacetophenone** is a specialized chemical scaffold primarily utilized in medicinal chemistry as a steric probe for the cyclooxygenase-2 (COX-2) enzyme.[1] While its homolog, 4-methylsulfonylacetophenone, serves as the foundational pharmacophore for the "coxib" class of drugs (e.g., Rofecoxib, Etoricoxib), the propyl derivative represents a critical tool for mapping the volumetric limits of the COX-2 secondary hydrophilic pocket.[1]

This guide details the synthetic pathways, structural logic, and biological applications of **4-propylsulfonylacetophenone** derivatives, specifically focusing on their utility in Structure-Activity Relationship (SAR) studies and as precursors for bioactive chalcones and pyrazoles.[1]

### The "Side Pocket" Theory

The therapeutic selectivity of COX-2 inhibitors over COX-1 relies on a single amino acid difference in the active site: Ile523 in COX-1 is replaced by the smaller Val523 in COX-2.[1] This substitution creates a secondary "side pocket" accessible only in COX-2.[1]

- Methylsulfone ( ): Fits perfectly, anchoring the drug.[1]
- Propylsulfone ( ): Used to test the depth and plasticity of this pocket.[1] If a derivative retains potency with a propyl group, it suggests the scaffold induces a conformational change or accesses an auxiliary binding region.[1]

## Chemical Identity & Properties

Property	4-Methylsulfonylacetophenone (Reference)	4-Propylsulfonylacetophenone (Target)
CAS No.	10297-73-1	Not Commercially Standardized
Formula		
Mol.[1] Weight	198.24 g/mol	226.29 g/mol
Lipophilicity (cLogP)	-0.9	-1.9 (Predicted)
H-Bond Acceptors	3 (Ketone + Sulfone)	3
Primary Utility	Drug Intermediate (Etoricoxib)	SAR Steric Probe / Chalcone Precursor

## Validated Synthetic Protocols

The synthesis of **4-propylsulfonylacetophenone** requires a robust, two-stage workflow: Nucleophilic Aromatic Substitution (

) followed by Oxidation.[1] This route is preferred over Friedel-Crafts acylation due to the deactivating nature of the sulfonyl group.[1]

## Workflow Diagram (DOT Visualization)

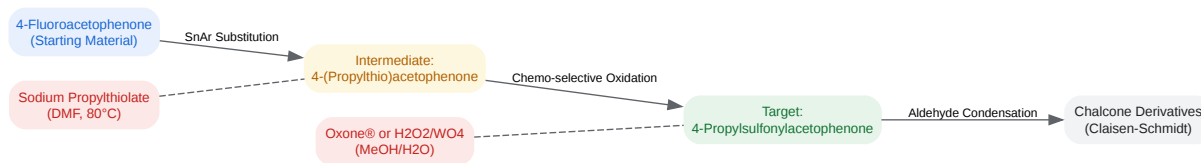

[Click to download full resolution via product page](#)

Caption: Two-step synthetic pathway transforming 4-fluoroacetophenone into the sulfonyl target via sulfide intermediate.

## Detailed Protocol

### Step 1: Thioether Formation (

)

Objective: Replace the fluorine atom with a propylthio group.[1]

- Reagents: 4-Fluoroacetophenone (1.0 eq), 1-Propanethiol (1.2 eq), (2.0 eq).[1]
- Solvent: DMF (Dimethylformamide) or DMSO.[1]
- Procedure:
  - Dissolve 4-fluoroacetophenone in dry DMF under atmosphere.
  - Add followed by dropwise addition of 1-propanethiol.[1]

- Heat to 80–90°C for 4–6 hours. Monitor by TLC (Mobile phase: Hexane/EtOAc 8:2). The starting fluoride (high Rf) will disappear, replaced by the sulfide (lower Rf).[1]
- Workup: Pour into ice water. The product, 4-(propylthio)acetophenone, usually precipitates as a solid or oil.[1] Extract with EtOAc if necessary.[1]

## Step 2: Oxidation to Sulfone

Objective: Oxidize the sulfide (

) to sulfone (

) without over-oxidizing the ketone or affecting the alkyl chain.[1]

- Reagents: Oxone® (Potassium peroxymonosulfate) (2.5 eq) OR (30%) with catalytic Sodium Tungstate ( ).[1]
- Solvent: Methanol/Water (1:1).[1]
- Procedure:
  - Dissolve the thioether from Step 1 in MeOH.[1]
  - Dissolve Oxone in water and add dropwise to the stirring MeOH solution at 0°C (exothermic reaction).
  - Allow to warm to room temperature and stir for 4 hours.
  - Causality: Oxone is preferred over mCPBA here because it is water-soluble and simplifies purification (the by-products are inorganic salts washed away with water).[1]
  - Validation: The sulfone product will be significantly more polar than the sulfide intermediate.[1]

## Derivatization: The Chalcone Pathway[1][2]

Once synthesized, **4-propylsulfonylacetophenone** acts as the "ketone" component in Claisen-Schmidt condensations.[1] This is the primary route to generating bioactive libraries.[1]

Reaction:

[1]

## Critical Experimental Considerations

- Solubility: The propylsulfonyl group increases lipophilicity compared to methylsulfonyl.[1] Use Ethanol/THF mixtures if the starting material crashes out of pure ethanol.[1]
- Electronic Effects: The sulfonyl group is strongly electron-withdrawing (EWG).[1] This increases the acidity of the -protons (methyl group), making the condensation reaction faster than with unsubstituted acetophenone.[1]

## Biological Relevance of Derivatives[1][2][3][4][5][6][7]

- COX-2 Inhibition: The chalcone mimics the diaryl structure of Coxibs.[1] The propylsulfonyl group probes the tolerance of the COX-2 active site.[1]
- MMP-2/9 Inhibition: Recent literature suggests sulfonyl-chalcones can inhibit Matrix Metalloproteinases (MMPs), key enzymes in cancer metastasis.[1] The propyl chain adds lipophilic bulk that may enhance binding to the MMP S1' pocket.[1]

## Structure-Activity Relationship (SAR) Logic[1]

The decision to use a propyl group is not arbitrary; it is a calculated "molecular ruler" experiment.

## COX-2 Selectivity Diagram (DOT Visualization)

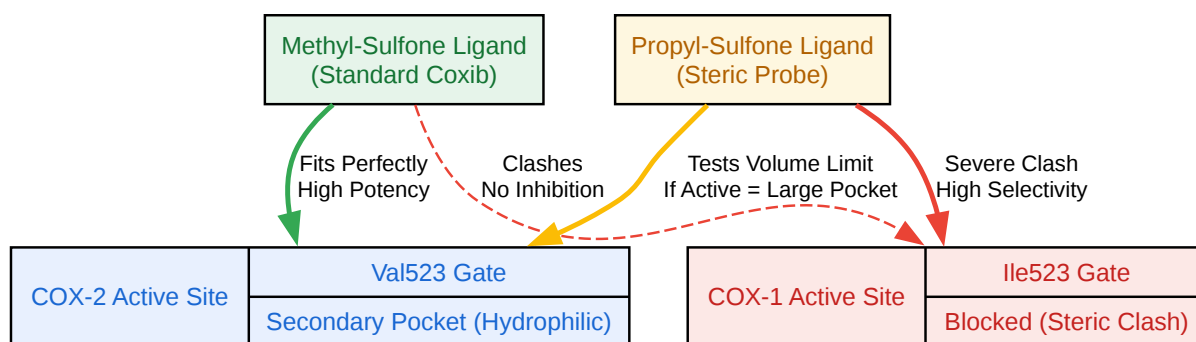

[Click to download full resolution via product page](#)

Caption: Schematic of how propyl-sulfonyl ligands probe the steric tolerance of the COX-2 Val523 "gate" vs. COX-1 Ile523.

## Interpretation of Results

- Retained Potency: If the propyl derivative retains high COX-2 inhibition, the enzyme pocket is flexible or larger than predicted.[1]
- Loss of Potency: If potency drops significantly compared to the methyl analog, the propyl group exceeds the steric volume of the side pocket (steric penalty).[1]

## References

- Zarghi, A., et al. (2011). Design and synthesis of new 1,3-diphenylprop-2-en-1-one derivatives as selective COX-2 inhibitors. *Bioorganic & Medicinal Chemistry Letters*. [Link](#)
- Kalgutkar, A. S., et al. (2000). Ester and Amide Derivatives of the Nonsteroidal Antiinflammatory Drug, Indomethacin, as Selective Cyclooxygenase-2 Inhibitors.[1] *Journal of Medicinal Chemistry*. [Link](#)[1]
- Hasan, A., et al. (2014). Synthesis, Characterization and Biological Evaluation of Some New Chalcone Derivatives. *Journal of Saudi Chemical Society*. [1] [Link](#)[1]
- Chowdhury, M. A., et al. (2010). COX-2 Inhibitors: A Review of Their Structure-Activity Relationships. *Journal of Pharmacy & Pharmaceutical Sciences*. [1] [Link](#)

- Li, J. J., et al. (2004). The Science and Rationale of COX-2 Inhibitors.[1]Neurochemical Research.[1] [Link](#)

### Need Custom Synthesis?

BenchChem offers custom synthesis for rare earth carbides and specific isotopic labeling.

Email: [info@benchchem.com](mailto:info@benchchem.com) or [Request Quote Online](#).

## Sources

- 1. CAS 403-42-9: 4'-Fluoroacetophenone | CymitQuimica [[cymitquimica.com](https://cymitquimica.com)]
- To cite this document: BenchChem. [Technical Monograph: 4-Propylsulfonylacetophenone Derivatives]. BenchChem, [2026]. [Online PDF]. Available at: [<https://www.benchchem.com/product/b562649/docs#technical-monograph-4-propylsulfonylacetophenone-derivatives>]

### Disclaimer & Data Validity:

The information provided in this document is for Research Use Only (RUO) and is strictly not intended for diagnostic or therapeutic procedures. While BenchChem strives to provide accurate protocols, we make no warranties, express or implied, regarding the fitness of this product for every specific experimental setup.

**Technical Support:** The protocols provided are for reference purposes. Unsure if this reagent suits your experiment?

**Need Industrial/Bulk Grade?** [Request Custom Synthesis Quote](#)

## BenchChem

Our mission is to be the trusted global source of essential and advanced chemicals, empowering scientists and researchers to drive progress in science and industry.

### Contact

Address: 3281 E Guasti Rd

Ontario, CA 91761, United States

Phone: (601) 213-4426

Email: [info@benchchem.com](mailto:info@benchchem.com)

Contact our Ph.D. Support Team for a compatibility check