

Validating the Selectivity of MKC9989 for IRE1 α : A Comparative Guide

Author: BenchChem Technical Support Team. **Date:** April 2026

Compound of Interest

Compound Name: MKC9989

Cat. No.: B560576

[Get Quote](#)

For Researchers, Scientists, and Drug Development Professionals

This guide provides an objective comparison of the IRE1 α inhibitor **MKC9989** with other known modulators of this critical endoplasmic reticulum (ER) stress sensor. The following sections present supporting experimental data, detailed methodologies for key validation assays, and visual representations of the relevant biological pathways and experimental workflows to aid in the comprehensive evaluation of **MKC9989**'s selectivity.

Introduction to IRE1 α and the Role of Inhibitors

Inositol-requiring enzyme 1 α (IRE1 α) is a key transducer of the Unfolded Protein Response (UPR), a cellular signaling network activated by ER stress. IRE1 α possesses both a kinase and a ribonuclease (RNase) domain. Upon activation, its RNase domain initiates the unconventional splicing of X-box binding protein 1 (XBP1) mRNA, leading to the production of the active transcription factor XBP1s. XBP1s, in turn, upregulates genes that enhance the cell's protein folding and degradation capacity. Given its central role in cell fate decisions under stress, IRE1 α has emerged as a significant therapeutic target in various diseases, including cancer and metabolic disorders. Small molecule inhibitors targeting either the kinase or RNase activity of IRE1 α are therefore valuable tools for research and potential therapeutic agents.

MKC9989 is a selective inhibitor of the RNase activity of IRE1 α .^[1] Its selectivity is attributed to the formation of a covalent Schiff base with the lysine residue K907 within the RNase catalytic site.^[1] This particular lysine residue exhibits a uniquely low pKa value compared to other lysines in IRE1 α , contributing to the high specificity of **MKC9989**.^[1] In silico molecular docking and dynamics simulations have further validated the selective binding of **MKC9989** to K907.

Comparative Analysis of IRE1 α Inhibitors

The following table summarizes the biochemical potency of **MKC9989** in comparison to other well-characterized IRE1 α inhibitors. The data is categorized by the targeted domain (RNase or kinase) to provide a clear overview of their mechanism of action. While **MKC9989** is reported to be highly selective, comprehensive off-target kinase panel data is not publicly available.

Inhibitor	Target Domain	Target	IC50	Off-Target Profile
MKC9989	RNase	IRE1 α	~0.33 μ M (EC50 for XBP1 splicing)	Not publicly available
4 μ 8C	RNase	IRE1 α	76 nM	Off-target effects reported
B-109	RNase	IRE1 α	1.23 μ M	-
STF-083010	RNase	IRE1 α	-	Specific for RNase, does not affect kinase activity
KIRA6	Kinase	IRE1 α	0.6 μ M	Low selectivity, multiple off-targets identified
KIRA8	Kinase	IRE1 α	5.9 nM (allosteric RNase inhibition)	Mono-selective
APY29	Kinase	IRE1 α	280 nM	-
Sunitinib	Kinase	Multi-kinase	80 nM (VEGFR2), also inhibits IRE1 α autophosphorylation	Broad (VEGFR2, PDGFR β , c-Kit, etc.)

Experimental Protocols for Validating Inhibitor Selectivity

Accurate determination of an inhibitor's selectivity and potency is paramount. The following are detailed methodologies for key experiments commonly employed in the characterization of IRE1 α inhibitors.

In Vitro IRE1 α RNase Activity Assay

This assay directly measures the ability of an inhibitor to block the endoribonuclease activity of IRE1 α using a fluorogenic substrate.

Materials:

- Recombinant human IRE1 α protein (cytoplasmic domain)
- Fluorescently labeled RNA oligonucleotide containing the XBP1 splice sites (e.g., with a fluorophore and a quencher)
- Assay buffer (e.g., 20 mM HEPES pH 7.5, 50 mM NaCl, 1 mM MgCl₂, 1 mM DTT)
- Test inhibitor (e.g., **MKC9989**) and vehicle control (e.g., DMSO)
- 384-well microplate
- Plate reader capable of fluorescence detection

Procedure:

- Prepare a serial dilution of the test inhibitor in assay buffer.
- In a 384-well plate, add the recombinant IRE1 α protein to each well.
- Add the diluted test inhibitor or vehicle control to the respective wells and incubate for a predetermined period (e.g., 30 minutes) at room temperature to allow for inhibitor binding.
- Initiate the reaction by adding the fluorescently labeled RNA substrate to all wells.
- Immediately begin monitoring the fluorescence intensity over time using a plate reader. Cleavage of the substrate by IRE1 α separates the fluorophore and quencher, resulting in an increase in fluorescence.
- Calculate the initial reaction rates for each inhibitor concentration.
- Plot the reaction rates against the inhibitor concentration and fit the data to a suitable dose-response curve to determine the IC₅₀ value.

XBP1 mRNA Splicing Assay in Cells

This cellular assay assesses the functional consequence of IRE1 α RNase inhibition by measuring the level of spliced XBP1 (XBP1s) mRNA.

Materials:

- Human cell line known to have a robust UPR (e.g., RPMI 8226, HEK293T)
- ER stress-inducing agent (e.g., thapsigargin, tunicamycin)
- Test inhibitor (e.g., **MKC9989**) and vehicle control
- Cell culture reagents
- RNA extraction kit
- Reverse transcription reagents
- PCR primers specific for total XBP1 and spliced XBP1
- qPCR instrument or standard PCR thermocycler and gel electrophoresis equipment

Procedure:

- Seed cells in a multi-well plate and allow them to adhere overnight.
- Pre-treat the cells with a serial dilution of the test inhibitor or vehicle for 1-2 hours.
- Induce ER stress by adding thapsigargin or tunicamycin to the media and incubate for a specified time (e.g., 4-6 hours).
- Harvest the cells and extract total RNA.
- Perform reverse transcription to generate cDNA.
- Quantify the levels of total XBP1 and spliced XBP1 mRNA using qPCR or semi-quantitative RT-PCR followed by gel electrophoresis.

- Normalize the amount of XBP1s to total XBP1 or a housekeeping gene.
- Plot the normalized XBP1s levels against the inhibitor concentration to determine the EC50 value.

In Vitro IRE1 α Kinase Activity Assay

This assay determines if an inhibitor affects the kinase activity of IRE1 α , which is responsible for its autophosphorylation and subsequent RNase activation.

Materials:

- Recombinant human IRE1 α protein (cytoplasmic domain)
- Kinase assay buffer (e.g., 25 mM Tris-HCl pH 7.5, 10 mM MgCl₂, 1 mM DTT)
- [γ -³²P]ATP or a non-radioactive ATP detection system (e.g., ADP-Glo™)
- Test inhibitor (e.g., **MKC9989**) and vehicle control
- SDS-PAGE equipment and autoradiography film or luminescence plate reader

Procedure:

- Prepare a serial dilution of the test inhibitor in kinase assay buffer.
- In a reaction tube, combine the recombinant IRE1 α protein with the diluted test inhibitor or vehicle and pre-incubate.
- Initiate the kinase reaction by adding ATP (e.g., [γ -³²P]ATP).
- Allow the reaction to proceed for a defined time at 30°C.
- Stop the reaction by adding SDS-PAGE loading buffer.
- Separate the proteins by SDS-PAGE.
- If using [γ -³²P]ATP, expose the gel to autoradiography film to visualize the phosphorylated IRE1 α . If using a luminescence-based assay, follow the manufacturer's protocol to measure

the remaining ATP.

- Quantify the band intensity or luminescent signal to determine the extent of kinase inhibition at each inhibitor concentration and calculate the IC50 value.

Cellular Thermal Shift Assay (CETSA)

CETSA is a powerful technique to verify direct target engagement of an inhibitor with its protein target in a cellular context. The principle is that ligand binding stabilizes the target protein against thermal denaturation.

Materials:

- Cells expressing IRE1 α
- Test inhibitor (e.g., **MKC9989**) and vehicle control
- Phosphate-buffered saline (PBS) with protease inhibitors
- PCR tubes
- Thermocycler or heating block
- Lysis buffer
- Centrifuge
- SDS-PAGE and Western blotting reagents
- Anti-IRE1 α antibody

Procedure:

- Treat cultured cells with the test inhibitor or vehicle for a specified time.
- Harvest the cells, wash with PBS, and resuspend in PBS with protease inhibitors.
- Aliquot the cell suspension into PCR tubes.

- Heat the tubes to a range of different temperatures for a short duration (e.g., 3 minutes).
- Lyse the cells by freeze-thaw cycles or with a suitable lysis buffer.
- Centrifuge the lysates at high speed to pellet the aggregated, denatured proteins.
- Collect the supernatant containing the soluble protein fraction.
- Analyze the amount of soluble IRE1 α in each sample by Western blotting using an anti-IRE1 α antibody.
- A positive thermal shift (i.e., more soluble IRE1 α at higher temperatures in the presence of the inhibitor) indicates target engagement.

Visualizing Pathways and Workflows

The following diagrams, generated using the DOT language, illustrate the IRE1 α signaling pathway and a typical experimental workflow for validating inhibitor selectivity.

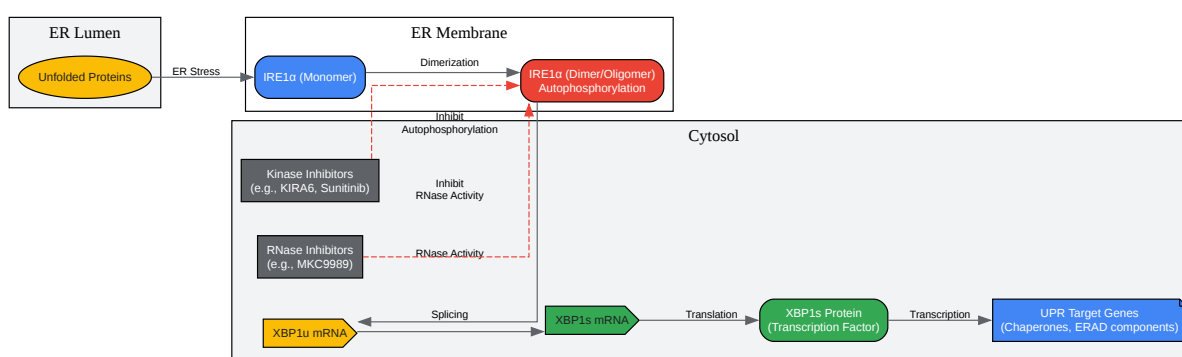

[Click to download full resolution via product page](#)

Caption: The IRE1 α signaling pathway in the Unfolded Protein Response.

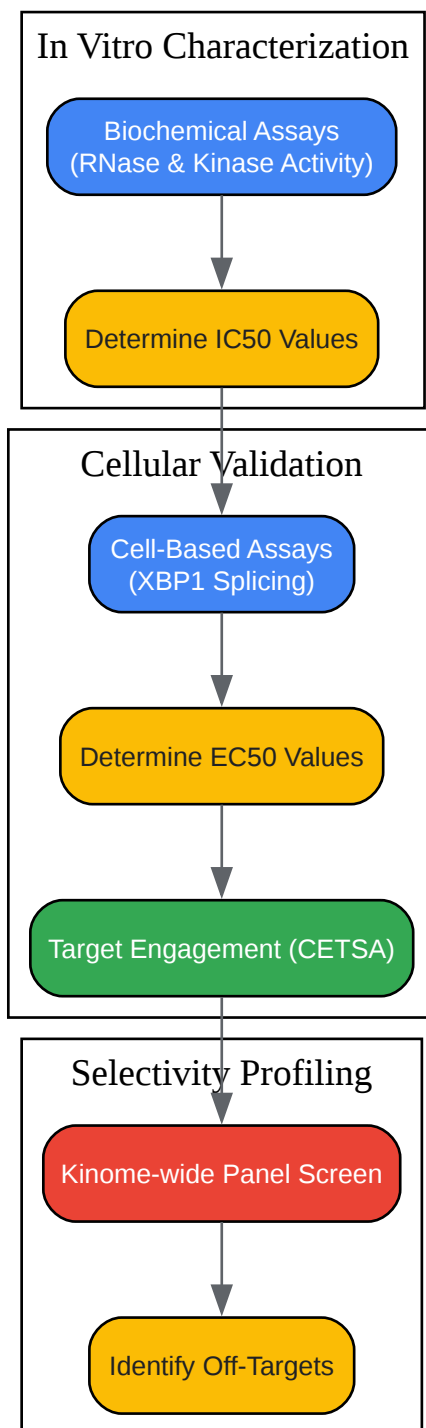

[Click to download full resolution via product page](#)

Need Custom Synthesis?

BenchChem offers custom synthesis for rare earth carbides and specific isotopic labeling.

Email: info@benchchem.com or [Request Quote Online](#).

References

- 1. Deciphering the selectivity of inhibitor MKC9989 towards residue K907 in IRE1 α ; a multiscale in silico approach - PMC [[pmc.ncbi.nlm.nih.gov](https://pubmed.ncbi.nlm.nih.gov/)]
- To cite this document: BenchChem. [Validating the Selectivity of MKC9989 for IRE1 α : A Comparative Guide]. BenchChem, [2026]. [Online PDF]. Available at: [<https://www.benchchem.com/product/b560576/docs#validating-the-selectivity-of-mkc9989-for-ire1-a-comparative-guide>]

Disclaimer & Data Validity:

The information provided in this document is for Research Use Only (RUO) and is strictly not intended for diagnostic or therapeutic procedures. While BenchChem strives to provide accurate protocols, we make no warranties, express or implied, regarding the fitness of this product for every specific experimental setup.

Technical Support: The protocols provided are for reference purposes. Unsure if this reagent suits your experiment?

Need Industrial/Bulk Grade? [Request Custom Synthesis Quote](#)

BenchChem

Our mission is to be the trusted global source of essential and advanced chemicals, empowering scientists and researchers to drive progress in science and industry.

Contact

Address: 3281 E Guasti Rd
Ontario, CA 91761, United States
Phone: (601) 213-4426
Email: info@benchchem.com

Contact our Ph.D. Support Team for a compatibility check