

# Technical Support Center: Ensuring Complete Dissolution of Research Compounds

**Author:** BenchChem Technical Support Team. **Date:** April 2026

## Compound of Interest

Compound Name: *RO2959 monohydrochloride*

Cat. No.: *B560445*

[Get Quote](#)

This technical support center provides troubleshooting guides and frequently asked questions (FAQs) to assist researchers, scientists, and drug development professionals in achieving complete dissolution of two distinct chemical compounds: the photoinitiator Irgacure 2959 and the CRAC channel inhibitor **RO2959 monohydrochloride**.

It has come to our attention that there may be some confusion between these two compounds. Please verify the identity of your compound before proceeding with any dissolution protocol.

- Irgacure 2959 is a photoinitiator used to initiate polymerization reactions upon exposure to UV light, commonly used in the formation of hydrogels.
- **RO2959 monohydrochloride** is a potent and selective CRAC (Ca<sup>2+</sup> release-activated Ca<sup>2+</sup>) channel inhibitor used in cell signaling research.<sup>[1][2]</sup>

This guide is divided into two sections to address the specific properties and handling requirements of each compound.

## Section 1: Irgacure 2959

Irgacure 2959 is a widely used photoinitiator in biomedical applications for creating hydrogels.

[3] However, its low water solubility can present challenges.[3]

## Troubleshooting Guide

Issue	Possible Cause	Solution
Powder is not dissolving in aqueous solution (e.g., PBS).	Low water solubility of Irgacure 2959.	<ol style="list-style-type: none"><li>1. Gently warm the solution in a water bath (40-60°C) for 20-30 minutes.</li><li>2. Vortex the solution intermittently to agitate any undissolved particles.</li><li>3. Consider dissolving in a small amount of a more soluble organic solvent like methanol, ethanol, or DMSO first, and then adding it to your aqueous solution. Be mindful of the final solvent concentration's potential effects on your experiment.</li></ol>
Solution is cloudy or contains visible particles.	Incomplete dissolution.	<ol style="list-style-type: none"><li>1. Increase the warming time and/or temperature (within the recommended range).</li><li>2. Increase the frequency of vortexing.</li><li>3. If using an organic solvent, ensure you are using a sufficient volume to fully dissolve the powder before adding it to the aqueous phase.</li></ol>
Precipitate forms after adding the Irgacure 2959 stock solution to the final hydrogel precursor solution.	The final concentration of Irgacure 2959 exceeds its solubility limit in the final solution.	<ol style="list-style-type: none"><li>1. Ensure the final concentration of Irgacure 2959 is within the recommended range for your application (typically 0.05% to 0.5% w/v).</li><li>2. Maintain a slightly elevated temperature (e.g., 37-40°C) while mixing the final solution before crosslinking.</li></ol>

## Frequently Asked Questions (FAQs)

Q1: What is the recommended solvent for Irgacure 2959?

A1: For applications where water is not a suitable solvent due to low solubility, methanol, ethanol, and DMSO are commonly used. For cell culture applications, it is crucial to keep the final concentration of these organic solvents low to avoid cytotoxicity.

Q2: Can I heat the Irgacure 2959 solution to aid dissolution?

A2: Yes, warming the solution in a water bath between 40-60°C can significantly improve the dissolution of Irgacure 2959 in aqueous buffers like PBS.[4]

Q3: What is a typical concentration range for Irgacure 2959 in hydrogel preparation?

A3: The concentration of Irgacure 2959 can be optimized for specific applications, but a common range is 0.05% to 0.5% (w/v).[3][5][6]

Q4: Is it necessary to protect the Irgacure 2959 solution from light?

A4: Yes, Irgacure 2959 is a photoinitiator and is sensitive to light. It is recommended to prepare and store the solution in a container protected from light, for example, by wrapping it in aluminum foil.[4]

## Quantitative Data: Solubility of Irgacure 2959

Solvent	Solubility	Notes
Water	Low	Warming can increase solubility.
Methanol	Soluble	A 10% (100 mg/ml) solution can be prepared.
Ethanol	Soluble	Often used to create stock solutions.
DMSO	Soluble	A good alternative for cell culture applications, but the final concentration must be carefully controlled.
PBS	Low	Requires heating and agitation for dissolution.[4]

## Experimental Protocol: Dissolving Irgacure 2959 in PBS

This protocol is adapted from a method for preparing an Irgacure 2959 solution for hydrogel formation.[4]

- Determine the required amount: Calculate the mass of Irgacure 2959 powder needed based on the desired final concentration and volume.
- Initial Mixing: Add the weighed Irgacure 2959 powder to the appropriate volume of PBS in a container that can be sealed and protected from light.
- Heating: Place the sealed container in a water bath set to 40-60°C for 20 minutes.
- Agitation: Remove the container from the water bath and vortex it to agitate any undissolved particles.
- Continued Heating: Return the container to the water bath for an additional 10 minutes.
- Final Check: Visually inspect the solution to ensure all particles have dissolved.

- Sterilization (if required): If sterility is required for cell culture applications, the solution can be filter-sterilized using a 0.22  $\mu\text{m}$  syringe filter.

## Experimental Workflow: Hydrogel Preparation

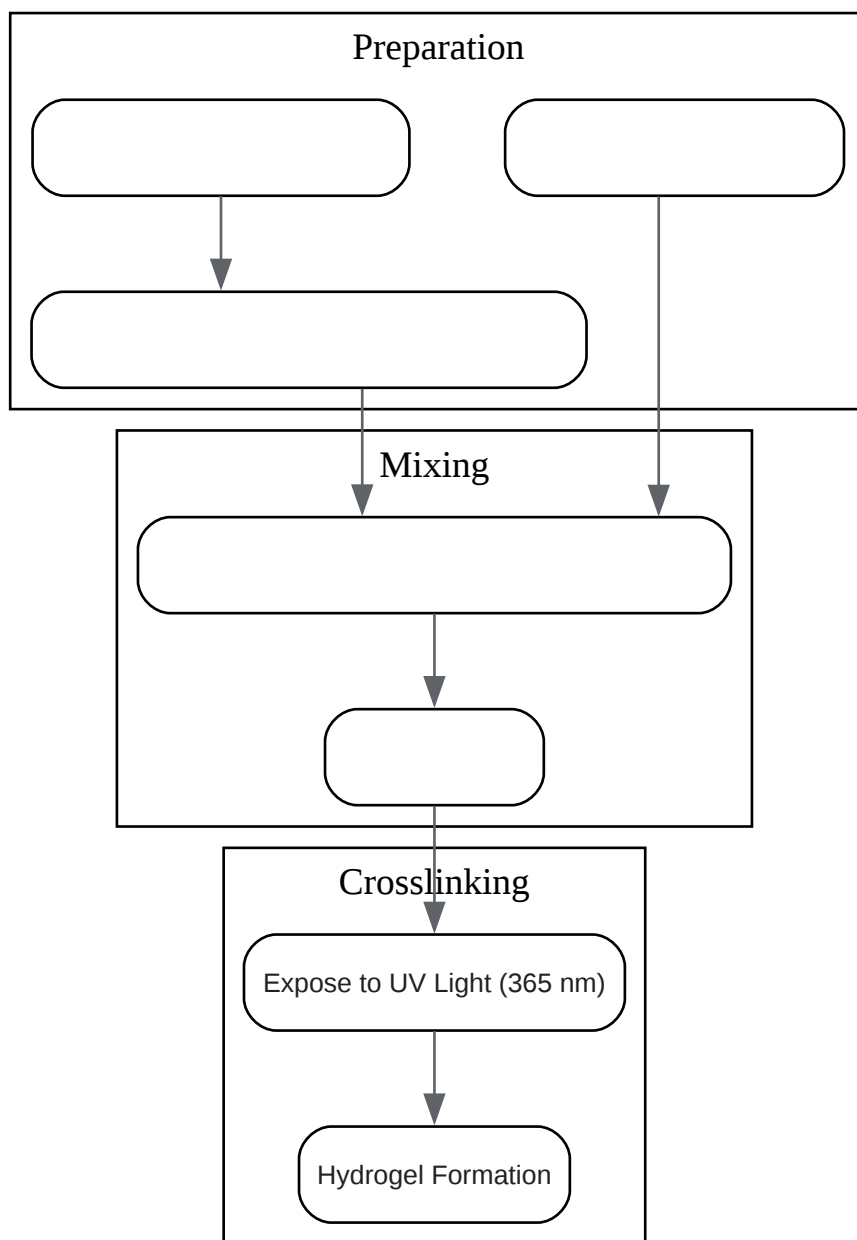

[Click to download full resolution via product page](#)

Workflow for photo-crosslinked hydrogel preparation.

## Section 2: RO2959 Monohydrochloride

**RO2959 monohydrochloride** is a potent and selective inhibitor of CRAC channels, which are involved in store-operated calcium entry (SOCE) in cells.[1][2] It is a valuable tool for studying T-cell activation and other calcium-dependent signaling pathways.[1][7]

## Troubleshooting Guide

Issue	Possible Cause	Solution
Powder is not dissolving in aqueous buffers.	RO2959 monohydrochloride has low aqueous solubility.	1. The recommended solvent for creating a stock solution is DMSO.[8][9][10] 2. For in vivo studies, specific co-solvent formulations are required to create a suspended solution. [1]
Precipitate forms when adding the DMSO stock solution to an aqueous medium.	The compound has precipitated out of the solution due to the change in solvent polarity.	1. It is recommended to first dilute the inhibitor with DMSO to form a gradient, and then add the diluted inhibitor to the buffer or cell culture medium. [9] 2. Ensure the final concentration of DMSO in the aqueous medium is low and compatible with your experimental system.
The solution appears as a suspension rather than a clear solution.	For certain applications, particularly in vivo, RO2959 monohydrochloride is formulated as a suspended solution.[1]	This is the expected outcome for the specified in vivo formulation protocol. Ensure the suspension is homogenous by mixing thoroughly before use.

## Frequently Asked questions (FAQs)

Q1: What is the best solvent for making a stock solution of **RO2959 monohydrochloride**?

A1: DMSO is the recommended solvent for preparing stock solutions of **RO2959 monohydrochloride**.[\[8\]](#)[\[9\]](#)[\[10\]](#)

Q2: Is **RO2959 monohydrochloride** soluble in water?

A2: No, **RO2959 monohydrochloride** is practically insoluble in water.[\[10\]](#)

Q3: How should I prepare **RO2959 monohydrochloride** for in vivo experiments?

A3: For in vivo use, **RO2959 monohydrochloride** is typically prepared as a suspended solution using a combination of solvents like DMSO, PEG300, Tween-80, and saline.[\[1\]](#)

## Quantitative Data: Solubility of RO2959 Monohydrochloride

Solvent	Solubility	Notes
DMSO	10 mM <a href="#">[8]</a> or 25 mg/mL (53.89 mM) <a href="#">[10]</a>	Sonication may be needed. <a href="#">[9]</a> <a href="#">[10]</a>
Water	< 0.1 mg/mL (insoluble) <a href="#">[10]</a>	
In vivo formulation (10% DMSO, 40% PEG300, 5% Tween-80, 45% Saline)	2.5 mg/mL (5.39 mM)	Forms a suspended solution; requires sonication. <a href="#">[1]</a>

## Experimental Protocol: Preparing a DMSO Stock Solution of RO2959 Monohydrochloride

- Calculate the required mass: Determine the amount of **RO2959 monohydrochloride** powder needed to achieve the desired stock solution concentration (e.g., 10 mM).
- Add Solvent: Add the appropriate volume of DMSO to the vial containing the powder.
- Aid Dissolution: If necessary, gently warm the vial and/or sonicate the solution to ensure complete dissolution.
- Storage: Store the stock solution at -20°C or -80°C for long-term stability.

## Signaling Pathway: CRAC Channel Activation

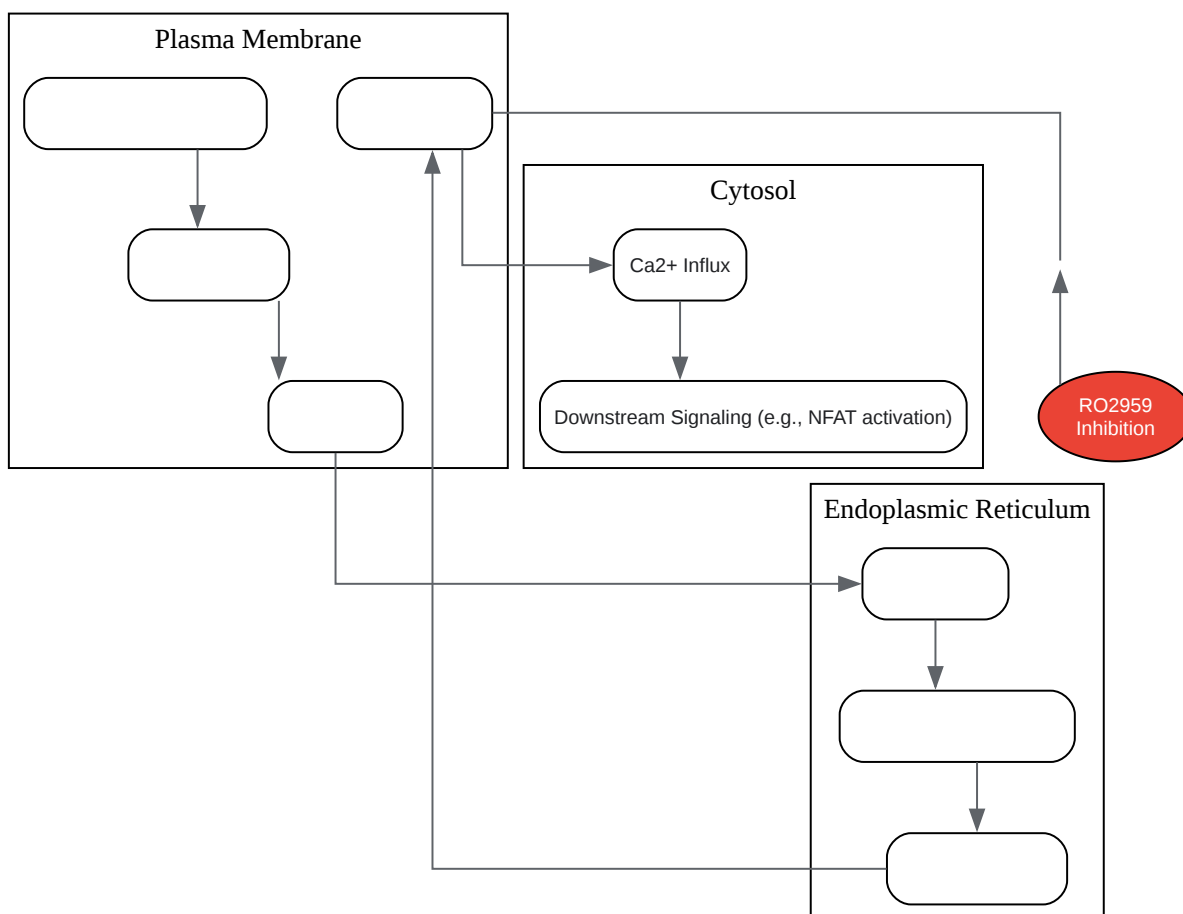

[Click to download full resolution via product page](#)

Simplified CRAC channel signaling pathway and the point of inhibition by RO2959.

### Need Custom Synthesis?

BenchChem offers custom synthesis for rare earth carbides and specific isotopic labeling.

Email: [info@benchchem.com](mailto:info@benchchem.com) or [Request Quote Online](#).

## References

- [1. medchemexpress.com \[medchemexpress.com\]](#)
- [2. file.medchemexpress.com \[file.medchemexpress.com\]](#)
- [3. bjhswm.com \[bjhswm.com\]](#)
- [4. okasciences.com \[okasciences.com\]](#)
- [5. Optimization of Irgacure® 2959 Concentration as Photo-Initiator on Chitosan-Alginate Based Hydrogel for Colon Tissue Sealant \[ijtech.eng.ui.ac.id\]](#)
- [6. researchgate.net \[researchgate.net\]](#)
- [7. medchemexpress.com \[medchemexpress.com\]](#)
- [8. RO2959 Hydrochloride | 1219927-22-6 | Calcium Channel | MOLNOVA \[molnova.com\]](#)
- [9. RO2959 Hydrochloride | Interleukin | IL Receptor | TargetMol \[targetmol.com\]](#)
- [10. arctomsci.com \[arctomsci.com\]](#)
- To cite this document: BenchChem. [Technical Support Center: Ensuring Complete Dissolution of Research Compounds]. BenchChem, [2026]. [Online PDF]. Available at: [<https://www.benchchem.com/product/b560445/docs#technical-support-center-ensuring-complete-dissolution-of-research-compounds>]

---

### Disclaimer & Data Validity:

The information provided in this document is for Research Use Only (RUO) and is strictly not intended for diagnostic or therapeutic procedures. While BenchChem strives to provide accurate protocols, we make no warranties, express or implied, regarding the fitness of this product for every specific experimental setup.

**Technical Support:** The protocols provided are for reference purposes. Unsure if this reagent suits your experiment?

**Need Industrial/Bulk Grade?** [Request Custom Synthesis Quote](#)

# BenchChem

Our mission is to be the trusted global source of essential and advanced chemicals, empowering scientists and researchers to drive progress in science and industry.

## Contact

Address: 3281 E Guasti Rd

Ontario, CA 91761, United States

Phone: (601) 213-4426

Email: [info@benchchem.com](mailto:info@benchchem.com)

[Contact our Ph.D. Support Team for a compatibility check](#)