

Fluo-3 AM: An In-depth Technical Guide for Cellular Calcium Imaging

Author: BenchChem Technical Support Team. **Date:** April 2026

Compound of Interest

Compound Name:	Fluo 3-AM
CAS No.:	121714-22-5
Cat. No.:	B056945

[Get Quote](#)

For Researchers, Scientists, and Drug Development Professionals

Introduction

Fluo-3 acetoxymethyl (AM) ester is a high-affinity, fluorescent dye widely utilized for the quantitative measurement of intracellular calcium ($[Ca^{2+}]_i$) concentrations.^{[1][2]} As a derivative of Fluo-3, its AM ester form renders the molecule cell-permeant, allowing for passive loading into a wide variety of cell types.^{[1][2]} Once inside the cell, non-specific esterases cleave the AM ester groups, trapping the active, calcium-sensitive Fluo-3 molecule in the cytoplasm.^{[2][3]} Fluo-3 is particularly valued for its large dynamic range, exhibiting a fluorescence intensity increase of over 40-fold upon binding to Ca^{2+} , making it an invaluable tool for studying cellular signaling pathways where calcium is a key second messenger.^{[1][4]} This guide provides a comprehensive overview of Fluo-3 AM, its mechanism of action, key quantitative data, detailed experimental protocols, and its application in studying cellular signaling.

Core Properties and Mechanism of Action

Fluo-3 AM is essentially non-fluorescent in its esterified form and in the absence of calcium.^[1] ^[4] The process of intracellular calcium measurement using Fluo-3 AM can be broken down into

three key steps:

- **Passive Loading:** The lipophilic AM ester groups facilitate the passage of Fluo-3 AM across the cell membrane into the cytosol.[\[2\]](#)
- **Intracellular Activation:** Cytosolic esterases hydrolyze the AM ester groups, yielding the membrane-impermeant, active form of Fluo-3. This process ensures that the indicator is trapped within the cell.[\[2\]](#)[\[3\]](#)
- **Calcium Binding and Fluorescence:** In its active form, Fluo-3 acts as a Ca^{2+} chelator. Upon binding to free intracellular calcium, its fluorescence quantum yield increases dramatically, resulting in a bright green fluorescence upon excitation.[\[3\]](#)[\[5\]](#)

The fluorescence intensity of Fluo-3 is directly proportional to the concentration of intracellular free calcium, allowing for the dynamic monitoring of calcium transients in real-time.

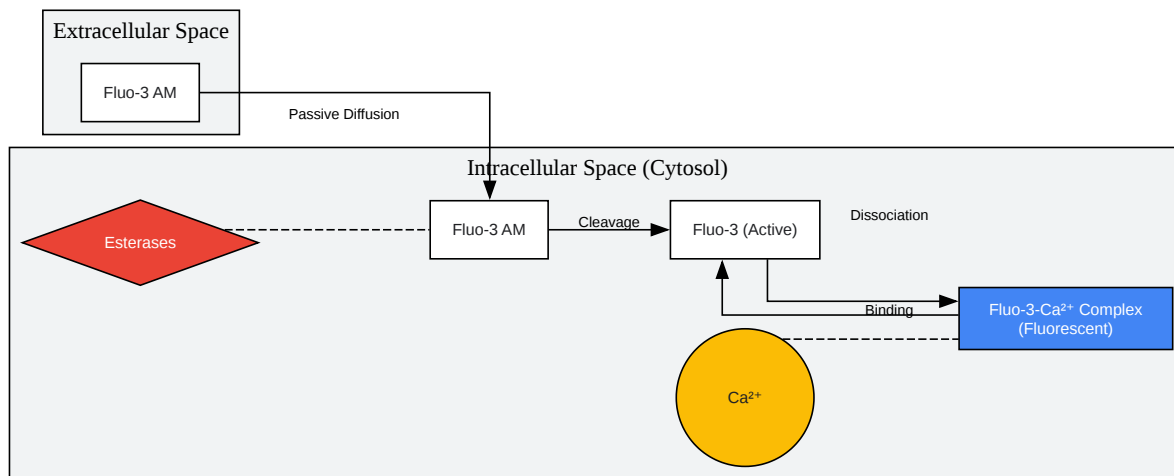

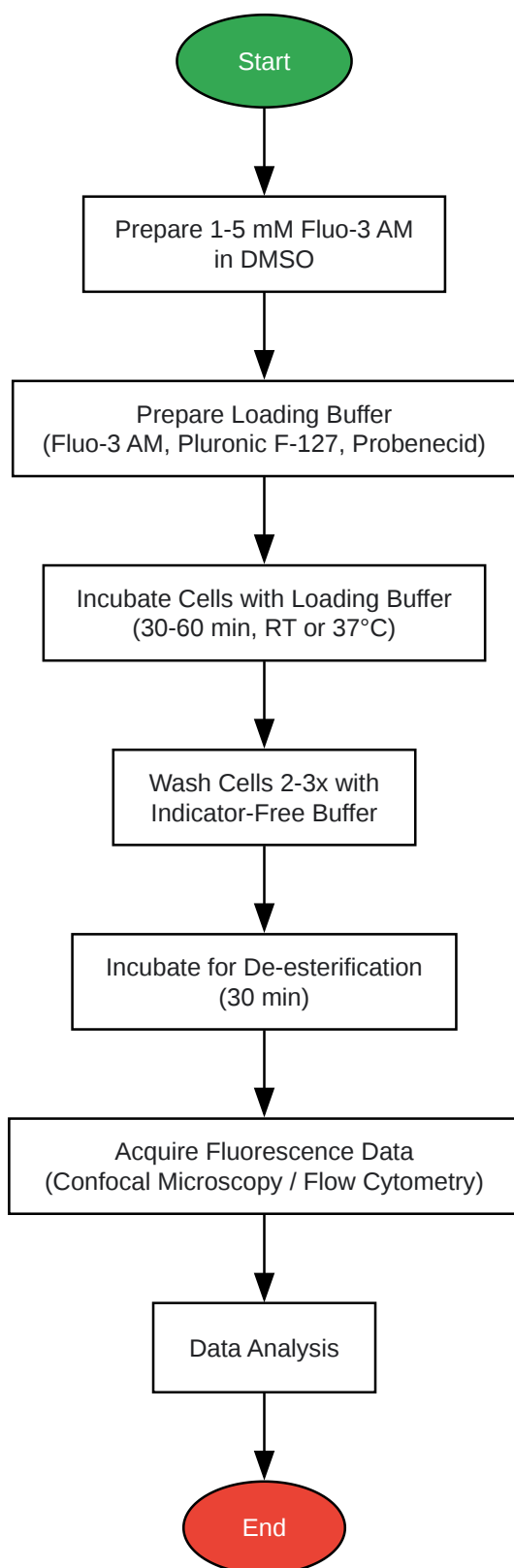

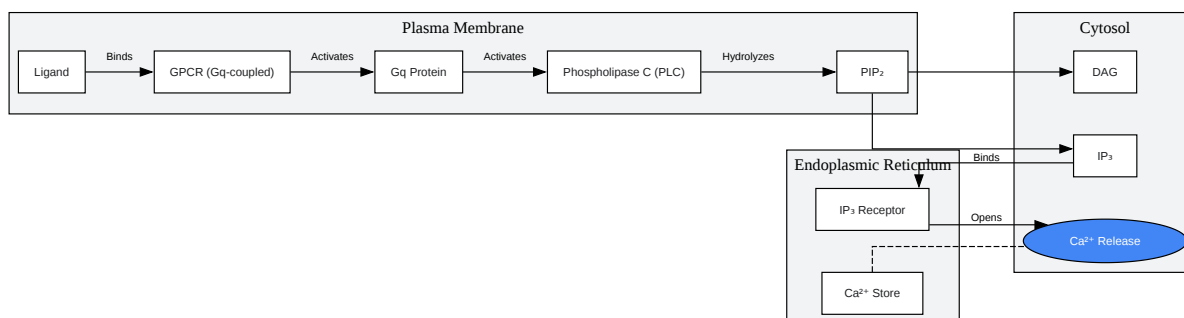

[Click to download full resolution via product page](#)

Need Custom Synthesis?

BenchChem offers custom synthesis for rare earth carbides and specific isotopic labeling.

Email: info@benchchem.com or [Request Quote Online](#).

References

- 1. [biotium.com](https://www.biotium.com) [biotium.com]
- 2. [Fluo-3 - Wikipedia](https://en.wikipedia.org/wiki/Fluo-3) [en.wikipedia.org]
- 3. [Fluo-3, AM *CAS 121714-22-5* | AAT Bioquest](https://www.aatbio.com) [aatbio.com]
- 4. [FLUO 3/AM Membrane-permeable version of FLUO 3. Unlike all other Ca²⁺ indicators, FLUO 3/AM is non-fluorescent until it is hydrolyzed in the cell by cellular esterases. It is insensitive to Mg²⁺. | Sigma-Aldrich](https://www.sigmaaldrich.com) [sigmaaldrich.com]
- 5. [Fluo-3 Calcium Indicator | Thermo Fisher Scientific - US](https://www.thermofisher.com) [thermofisher.com]
- To cite this document: BenchChem. [Fluo-3 AM: An In-depth Technical Guide for Cellular Calcium Imaging]. BenchChem, [2026]. [Online PDF]. Available at:

[\[https://www.benchchem.com/product/b056945/docs#fluo-3-am-an-in-depth-technical-guide-for-cellular-calcium-imaging\]](https://www.benchchem.com/product/b056945/docs#fluo-3-am-an-in-depth-technical-guide-for-cellular-calcium-imaging)

Disclaimer & Data Validity:

The information provided in this document is for Research Use Only (RUO) and is strictly not intended for diagnostic or therapeutic procedures. While BenchChem strives to provide accurate protocols, we make no warranties, express or implied, regarding the fitness of this product for every specific experimental setup.

Technical Support: The protocols provided are for reference purposes. Unsure if this reagent suits your experiment?

Need Industrial/Bulk Grade? [Request Custom Synthesis Quote](#)

BenchChem

Our mission is to be the trusted global source of essential and advanced chemicals, empowering scientists and researchers to drive progress in science and industry.

Contact

Address: 3281 E Guasti Rd
Ontario, CA 91761, United States
Phone: (601) 213-4426
Email: info@benchchem.com

[Contact our Ph.D. Support Team for a compatibility check](#)