

# Technical Support Center: Optimization of Boc-Phenylalanine Activation

**Author:** BenchChem Technical Support Team. **Date:** May 2026

## Compound of Interest

Compound Name: 2-(tert-butoxycarbonylamino)-3-phenylpropanoic acid

CAS No.: 4530-18-1

Cat. No.: B558496

[Get Quote](#)

This guide is designed for researchers, scientists, and professionals in drug development who are working with Boc-L-phenylalanine and need to optimize its activation for subsequent reactions, such as peptide synthesis or the formation of other amide bond-containing molecules. As a Senior Application Scientist, this document synthesizes technical expertise with practical, field-tested advice to help you troubleshoot common issues and answer frequently asked questions.

## Troubleshooting Guide: Overcoming Common Hurdles in Boc-Phenylalanine Activation

This section addresses specific problems you might encounter during the activation of Boc-phenylalanine (Boc-Phe-OH).

**Q1: My Boc-phenylalanine activation reaction is slow or incomplete. What are the likely causes and how can I resolve this?**

An incomplete or sluggish activation of Boc-Phe-OH is a frequent challenge. The root cause often lies in the reaction conditions or the integrity of the reagents.

#### Possible Causes and Solutions:

- **Inadequate Activation Reagents:** The choice and quality of your activating agents are paramount. For carbodiimide-mediated activations (e.g., DCC, EDC), ensure they are fresh and have been stored under anhydrous conditions. Carbodiimides are susceptible to hydration, which inactivates them.
- **Insufficient Reagent Stoichiometry:** Ensure you are using a sufficient excess of the coupling reagents. For a typical activation with DCC/HOBt, using 1.1-1.2 equivalents of both DCC and HOBt relative to Boc-Phe-OH is a good starting point.<sup>[1]</sup>
- **Poor Solubility:** Boc-Phe-OH and the activating agents must be fully dissolved for the reaction to proceed efficiently. If you observe poor solubility in your chosen solvent (e.g., Dichloromethane - DCM), consider switching to or adding a more polar aprotic solvent like Dimethylformamide (DMF) or Tetrahydrofuran (THF).<sup>[2][3]</sup>
- **Low Temperature:** While some activation reactions are initiated at 0°C to minimize side reactions, maintaining this low temperature for an extended period can significantly slow down the reaction rate. After the initial mixing at 0°C, consider allowing the reaction to gradually warm to room temperature.<sup>[1]</sup>
- **Presence of Moisture:** Water will react with the activated Boc-Phe-OH, hydrolyzing it back to the starting carboxylic acid. Ensure all glassware is oven-dried and that anhydrous solvents are used.

#### Experimental Protocol for Optimizing Activation:

- **Reagent Check:** Use fresh N,N'-Dicyclohexylcarbodiimide (DCC) and 1-Hydroxybenzotriazole (HOBt).
- **Solvent Selection:** Dissolve Boc-Phe-OH (1 eq) and HOBt (1.2 eq) in anhydrous DCM or a mixture of DCM/DMF.

- Activation: Cool the solution to 0°C in an ice bath. Add a solution of DCC (1.1 eq) in the same solvent.
- Reaction Monitoring: Stir the reaction at 0°C for 30 minutes, then allow it to warm to room temperature. Monitor the progress by Thin Layer Chromatography (TLC) by taking aliquots and quenching them with a primary amine (e.g., benzylamine) to form a stable amide that can be easily visualized.
- Troubleshooting Flow: If the reaction is still incomplete after 2-4 hours, consider the troubleshooting workflow illustrated below.

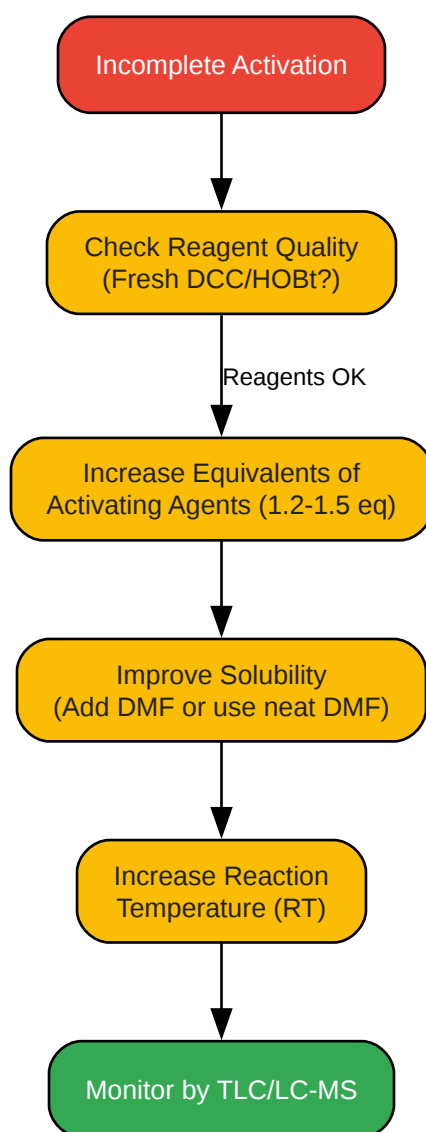

[Click to download full resolution via product page](#)

Caption: Troubleshooting workflow for incomplete Boc-Phe-OH activation.

## Q2: I'm observing significant byproduct formation during the activation of Boc-Phe-OH. What are these byproducts and how can I prevent them?

The formation of byproducts not only reduces the yield of your desired activated species but can also complicate the subsequent coupling reaction and purification.

Common Byproducts and Prevention Strategies:

- N-acylurea: This is a common byproduct when using carbodiimides like DCC. The activated O-acylisourea intermediate can rearrange to a more stable, unreactive N-acylurea.
  - Prevention: The addition of a nucleophilic additive like HOBt or 1-hydroxy-7-azabenzotriazole (HOAt) is crucial. These additives rapidly trap the O-acylisourea to form an active ester, which is less prone to rearrangement.[\[2\]](#)[\[3\]](#)
- Dicyclohexylurea (DCU): When using DCC, the hydrated form, DCU, is an unavoidable byproduct. While not a side reaction of the Boc-Phe-OH itself, its precipitation can sometimes trap the activated species.
  - Management: DCU is poorly soluble in many organic solvents and can be removed by filtration.
- Oxazolone Formation: The activated Boc-amino acid can cyclize to form a 2-tert-butoxyoxazol-5(4H)-one. This can lead to racemization, especially if a base is present.
  - Prevention: Perform the activation at low temperatures (0°C) and in the absence of a strong base. The use of HOBt can also help to suppress this side reaction.[\[4\]](#)

Byproduct	Cause	Prevention Strategy
N-acylurea	Rearrangement of O-acylisourea intermediate	Use of additives like HOBt or HOAt.
Oxazolone	Intramolecular cyclization of the activated amino acid	Maintain low reaction temperatures (0°C). Avoid excess base.
Racemization	Often proceeds through an oxazolone intermediate	Use of racemization-suppressing additives (HOBt, HOAt).

## Frequently Asked Questions (FAQs)

This section provides answers to more general questions regarding the activation of Boc-phenylalanine.

### Q1: What are the most common and effective methods for activating Boc-phenylalanine?

The choice of activation method depends on the subsequent application, but for general purposes like peptide synthesis, the formation of active esters is highly reliable.

- **Carbodiimide/Additive Method** (e.g., DCC/HOBt or EDC/HOBt): This is one of the most widely used methods. The carbodiimide (DCC or EDC) activates the carboxylic acid, and HOBt acts as an additive to form a more stable and reactive HOBt-ester, while also minimizing racemization.<sup>[2][3]</sup> EDC is often preferred for solution-phase synthesis as its urea byproduct is water-soluble, simplifying purification.
- **Pre-formed Active Esters**: One can also use pre-formed active esters of Boc-Phe-OH, such as the N-hydroxysuccinimide (NHS) ester or the pentafluorophenyl (Pfp) ester. These reagents are stable and can be stored, offering convenience.
- **Symmetrical Anhydrides**: Formation of a symmetrical anhydride using a carbodiimide (2 equivalents of Boc-Phe-OH to 1 equivalent of DCC) is a highly reactive option, often leading to faster reaction times.

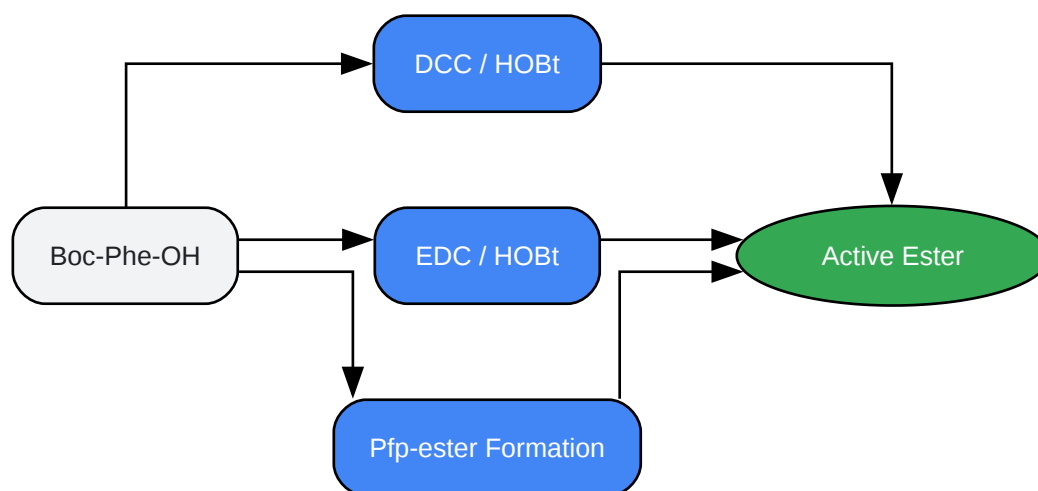

[Click to download full resolution via product page](#)

Caption: Common pathways for the activation of Boc-Phe-OH.

## Q2: How does reaction temperature influence the activation time of Boc-phenylalanine?

Temperature is a critical parameter that affects both the rate of activation and the prevalence of side reactions.

- **Increased Temperature, Increased Rate:** As with most chemical reactions, increasing the temperature will generally increase the rate of activation. The hydrophobic nature of the phenylalanine side chain also becomes more pronounced at higher temperatures, which can influence solvation and reactivity.[5]
- **Higher Temperature, More Side Reactions:** The trade-off for a faster reaction at elevated temperatures is an increased risk of side reactions, most notably racemization. For enantiopure starting materials, this is a significant concern. Studies on amino acid metabolism in other contexts have shown that higher temperatures can alter metabolic pathways, and while not a direct analogy, it underscores the sensitivity of amino acid chemistry to temperature.[6][7]

Recommended Temperature Profile:

Temperature	Expected Outcome	Best For
0°C	Slower activation, minimal racemization.	Reactions where maintaining stereochemical integrity is paramount.
Room Temperature (~25°C)	Faster activation, slight increase in racemization risk.	Standard operating procedure for many coupling reactions.[8]
> 40°C	Rapid activation, significant risk of racemization and other side reactions.	Generally not recommended unless empirically determined to be safe for a specific, robust reaction.

### Q3: What is a standard protocol for a small-scale activation of Boc-Phe-OH using DCC/HOBt for subsequent coupling?

This protocol outlines a reliable method for the activation of Boc-Phe-OH in solution, suitable for coupling to a free amine.

Materials:

- Boc-L-phenylalanine (Boc-Phe-OH)
- N,N'-Dicyclohexylcarbodiimide (DCC)
- 1-Hydroxybenzotriazole (HOBt)
- Anhydrous Dichloromethane (DCM)
- Anhydrous N,N-Diisopropylethylamine (DIPEA)
- Amine hydrochloride salt (e.g., H-Gly-OMe.HCl)
- Magnetic stirrer and stir bar
- Ice bath

- Round-bottom flasks

#### Experimental Protocol:

- **Amine Neutralization:** In a round-bottom flask, dissolve the amine hydrochloride salt (1.0 eq) in anhydrous DCM. Add DIPEA (1.1 eq) and stir at room temperature for 15-20 minutes.
- **Acid Activation:** In a separate flask, dissolve Boc-Phe-OH (1.0 eq) and HOBt (1.2 eq) in anhydrous DCM.
- **Cooling:** Cool the solution from step 2 to 0°C in an ice bath.
- **Carbodiimide Addition:** Add a solution of DCC (1.1 eq) in DCM to the cooled reaction mixture from step 2.
- **Pre-activation:** Stir this mixture at 0°C for 30 minutes. A white precipitate of dicyclohexylurea (DCU) may begin to form.<sup>[1]</sup>
- **Coupling:** To the activated Boc-Phe-OH solution, add the neutralized amine solution from step 1.
- **Reaction:** Allow the reaction to stir at 0°C for 2 hours and then at room temperature overnight.
- **Work-up:** Filter the reaction mixture to remove the precipitated DCU. Wash the filtrate sequentially with 1 M HCl, saturated NaHCO<sub>3</sub> solution, and brine. Dry the organic layer over anhydrous Na<sub>2</sub>SO<sub>4</sub>, filter, and concentrate under reduced pressure to obtain the crude product.
- **Purification:** Purify the crude dipeptide by flash column chromatography on silica gel.

#### **Need Custom Synthesis?**

BenchChem offers custom synthesis for rare earth carbides and specific isotopic labeling.

Email: [info@benchchem.com](mailto:info@benchchem.com) or [Request Quote Online](#).

## References

- [1. benchchem.com \[benchchem.com\]](#)
- [2. A practical method for the synthesis of small peptides using DCC and HOBt as activators in H<sub>2</sub>O–THF while avoiding the use of protecting groups - RSC Advances \(RSC Publishing\) DOI:10.1039/D4RA07847K \[pubs.rsc.org\]](#)
- [3. pubs.rsc.org \[pubs.rsc.org\]](#)
- [4. Thieme E-Books & E-Journals \[thieme-connect.de\]](#)
- [5. Temperature dependence of amino acid hydrophobicities - PMC \[pmc.ncbi.nlm.nih.gov\]](#)
- [6. Physiological high temperatures alter the amino acid metabolism of bovine early antral follicles - PMC \[pmc.ncbi.nlm.nih.gov\]](#)
- [7. researchgate.net \[researchgate.net\]](#)
- [8. Structural Optimization of Carboxy-Terminal Phenylalanine-Modified Dendrimers for T-Cell Association and Model Drug Loading - PMC \[pmc.ncbi.nlm.nih.gov\]](#)
- To cite this document: BenchChem. [Technical Support Center: Optimization of Boc-Phenylalanine Activation]. BenchChem, [2026]. [Online PDF]. Available at: [\[https://www.benchchem.com/product/b558496/docs#technical-support-center-optimization-of-boc-phenylalanine-activation\]](https://www.benchchem.com/product/b558496/docs#technical-support-center-optimization-of-boc-phenylalanine-activation)

---

### Disclaimer & Data Validity:

The information provided in this document is for Research Use Only (RUO) and is strictly not intended for diagnostic or therapeutic procedures. While BenchChem strives to provide accurate protocols, we make no warranties, express or implied, regarding the fitness of this product for every specific experimental setup.

**Technical Support:** The protocols provided are for reference purposes. Unsure if this reagent suits your experiment?

**Need Industrial/Bulk Grade?** [Request Custom Synthesis Quote](#)

# BenchChem

Our mission is to be the trusted global source of essential and advanced chemicals, empowering scientists and researchers to drive progress in science and industry.

## Contact

Address: 3281 E Guasti Rd

Ontario, CA 91761, United States

Phone: (601) 213-4426

Email: [info@benchchem.com](mailto:info@benchchem.com)

[Contact our Ph.D. Support Team for a compatibility check](#)