

Technical Support Center: Boc-Phe-OH Solubility & Reaction Setup

Author: BenchChem Technical Support Team. **Date:** May 2026

Compound of Interest

Compound Name: 2-(tert-butoxycarbonylamino)-3-phenylpropanoic acid

CAS No.: 4530-18-1

Cat. No.: B558496

[Get Quote](#)

A Guide for Researchers, Scientists, and Drug Development Professionals

Frequently Asked Questions (FAQs)

Q1: What are the general solubility characteristics of Boc-Phe-OH?

A1: Boc-Phe-OH is a hydrophobic, protected amino acid. Due to the presence of the bulky, nonpolar tert-butoxycarbonyl (Boc) group and the phenyl side chain, it is generally insoluble in water. However, it is soluble in a range of common organic solvents used in peptide synthesis and organic chemistry.^{[1][2]}

Q2: Which organic solvents are recommended for dissolving Boc-Phe-OH?

A2: Boc-Phe-OH is widely reported to be soluble in polar aprotic solvents such as N,N-Dimethylformamide (DMF), Dichloromethane (DCM), and N-Methyl-2-pyrrolidone (NMP).^[1] It also shows solubility in other solvents like methanol.^[2] The choice of solvent often depends on the specific requirements of the subsequent reaction, such as a peptide coupling or deprotection step.

Q3: I'm using a recommended solvent, but my Boc-Phe-OH is not dissolving. What are the common causes?

A3: Several factors can lead to poor solubility even in appropriate solvents:

- **Solvent Quality:** The presence of even small amounts of water or other impurities in your solvent can significantly reduce the solubility of hydrophobic compounds like Boc-Phe-OH.^[3]
- **Temperature:** Lower ambient temperatures can decrease the solubility of most solids.
- **Concentration:** You may be attempting to create a solution that exceeds the saturation point of Boc-Phe-OH in that specific solvent.
- **Compound Purity:** Impurities within the Boc-Phe-OH reagent itself can sometimes affect its dissolution characteristics.

Troubleshooting Guide: Improving Boc-Phe-OH Solubility

If you are encountering difficulties dissolving Boc-Phe-OH for your reaction, the following troubleshooting steps and advanced techniques can be employed.

Initial Troubleshooting Workflow

This workflow provides a systematic approach to addressing common solubility issues.

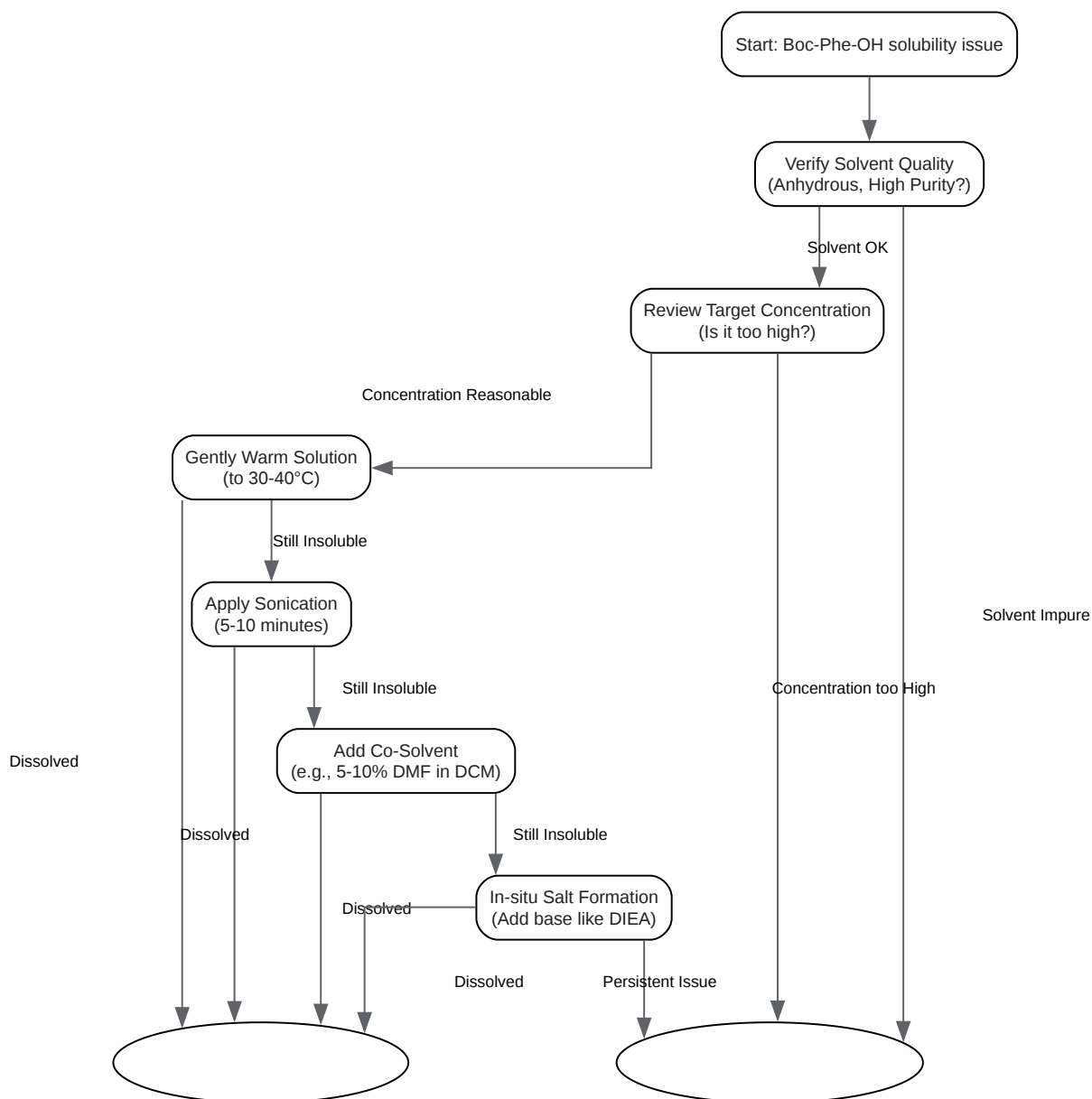

[Click to download full resolution via product page](#)

Caption: Decision workflow for troubleshooting Boc-Phe-OH solubility.

Solubility Data Summary

While comprehensive quantitative data is not widely published, the following table summarizes known solubility information for Boc-Phe-OH.

Solvent/System	Solubility	Source(s)	Notes
Dichloromethane (DCM)	Soluble	[1][2]	A common solvent for Boc-chemistry; good for swelling polystyrene resins.[4]
N,N-Dimethylformamide (DMF)	Soluble	[1][2]	Excellent solvating properties for most peptide synthesis reagents.[5]
N-Methyl-2-pyrrolidone (NMP)	Soluble	[1]	A strong polar aprotic solvent, often used as an alternative to DMF.
Methanol	Soluble	[2]	A polar protic solvent.
DMSO/PEG300/Tween-80/Saline	≥ 2.5 mg/mL	[6]	Data from a formulation for in-vivo studies.

Advanced Solubility Enhancement Techniques

Technique 1: In-situ Salt Formation for Coupling Reactions

Causality: The carboxylic acid moiety of Boc-Phe-OH (pKa ~3-4) can be deprotonated by a non-nucleophilic organic base, such as Diisopropylethylamine (DIEA) or Triethylamine (TEA), to form an ammonium salt.[7] This salt is significantly more polar than the free acid, leading to a substantial increase in solubility in polar organic solvents like DMF and DCM.[8] This is the most common and effective method used during peptide coupling reactions.

Experimental Protocol: Dissolving Boc-Phe-OH for a Standard Peptide Coupling

This protocol describes the pre-activation and dissolution of Boc-Phe-OH for coupling onto a resin-bound amine.

- **Preparation:** In a clean, dry reaction vessel, weigh the required amount of Boc-Phe-OH (typically 2-5 equivalents relative to the resin loading).
- **Solvent Addition:** Add the primary anhydrous reaction solvent (e.g., DMF or DCM) to the Boc-Phe-OH. Stir the suspension.
- **Coupling Reagent Addition:** If not already dissolved, add your coupling reagent (e.g., HBTU, HATU) to the suspension.
- **Base Addition (Key Step):** Add the non-nucleophilic base (e.g., DIEA, 2-4 equivalents). Stir the mixture. You should observe the Boc-Phe-OH dissolving rapidly as the highly soluble triethylammonium or diisopropylethylammonium salt is formed in situ.
- **Activation:** Allow the activation to proceed for a few minutes at room temperature before adding the solution to your deprotected resin.

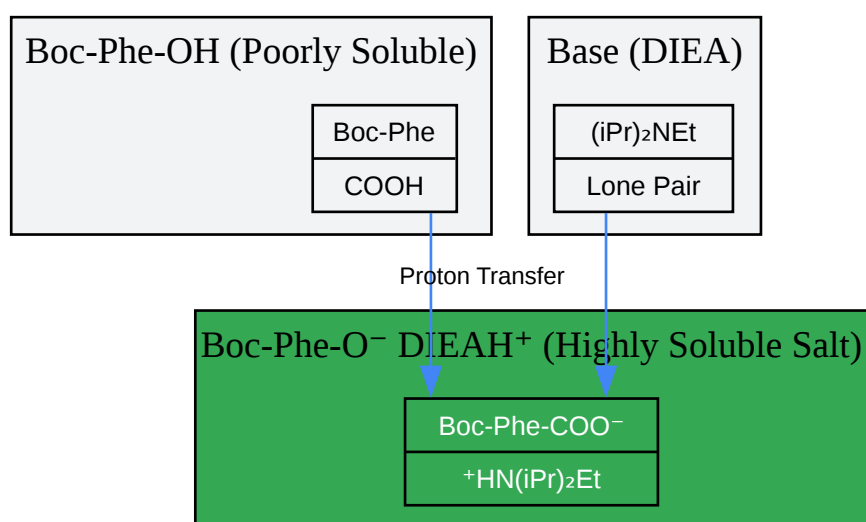

[Click to download full resolution via product page](#)

Caption: In-situ salt formation enhances Boc-Phe-OH solubility.

Technique 2: Utilizing Co-Solvent Systems

Causality: If a reaction must be performed in a less-polar solvent where Boc-Phe-OH has limited solubility (e.g., DCM), adding a small percentage of a stronger, more polar aprotic solvent can disrupt crystal lattice energy and improve solvation.

Experimental Protocol: Using a Co-Solvent

- Suspend the Boc-Phe-OH in the primary solvent (e.g., 10 mL of DCM).
- While stirring, add a small volume of a co-solvent, such as DMF or NMP, dropwise. Typically, 5-10% (v/v) is sufficient (e.g., 0.5-1.0 mL).
- Continue stirring until the solid is fully dissolved before proceeding with the reaction.

Technique 3: Physical Dissolution Aids

Causality: Mechanical energy can help break down aggregates and overcome the activation energy required for dissolution.

- Gentle Warming: Increasing the kinetic energy of the solvent molecules can enhance the dissolution rate. Warm the mixture gently to 30-40°C. Avoid excessive heat, which could potentially lead to the degradation of the acid-labile Boc group.
- Sonication: Applying ultrasonic frequencies can effectively break apart solid aggregates, increasing the surface area available for solvation. Place the sealed vial containing the suspension in an ultrasonic bath for 5-10 minute intervals.

References

- Aapptec. (n.d.). Standard Coupling Procedures; DIC/HOBt; PyBOP; HBTU; PyBrOP.
- MedChemExpress. (n.d.). Boc-L-phenylalanine.
- Aapptec. (n.d.). Boc-Phe-OH [13734-34-4].
- Aapptec. (n.d.). Practical Synthesis Guide to Solid Phase Peptide Chemistry.
- University of California, Irvine Department of Chemistry. (n.d.). Standard practices for Fmoc-based solid-phase peptide synthesis in the Nowick laboratory (Version 1.7.2).
- Fields, G. B., & Noble, R. L. (1990). Solid phase peptide synthesis utilizing 9-fluorenylmethoxycarbonyl amino acids. *International journal of peptide and protein research*, 35(3), 161–214.
- Fisher Scientific. (n.d.). N-Boc-L-phenylalanine, 99%.

- BenchChem. (2025). Application Notes and Protocols for Boc-Phe-Phe-OH in Peptide-Based Drug Development.
- BenchChem. (2025). An In-depth Technical Guide to Boc-Phe-Phe-OH for Researchers and Drug Development Professionals.
- BenchChem. (2025). Solubility issues of Boc-DL-Phg-OH in peptide synthesis solvents.
- BenchChem. (2025). Solubility of Fmoc-Phe(4-Br)-OH in DMF: A Technical Guide.
- BenchChem. (2025). Solubility of Triethylmethylammonium chloride in organic solvents.
- Sigma-Aldrich. (n.d.). Boc-Phe-OH $\geq 99.0\%$ (T).
- ResearchGate. (2017). What happens when amino acids are added to triethylamine?.
- Albericio, F., & Carpino, L. A. (2014). Methods and protocols of modern solid phase peptide synthesis. *Methods in molecular biology* (Clifton, N.J.), 1184, 1-27.
- Aapptec. (n.d.). Boc-Phe-OH, N-Boc-L-phenylalanine; CAS 13734-34-4.
- Benoiton, N. L. (2005). *Chemistry of peptide synthesis*. CRC press.
- Organic Chemistry Portal. (n.d.). Boc-Protected Amino Groups.
- Sigma-Aldrich. (n.d.). Boc-Phe-OH Novabiochem®.
- BenchChem. (2025). A Comparative Guide to Boc-Phe(4-Br)-OH and Other Modified Phenylalanine Derivatives in Peptide-Based Drug Discovery.
- Grzonka, Z., & Gzella, A. K. (2014). The case of triethylammonium cation loss during purification of certain nucleotide analogues: a cautionary note. *Analytical and bioanalytical chemistry*, 407(5), 1367-1378.
- ScienceMadness Discussion Board. (2011). Triethylamine complexes.

Need Custom Synthesis?

BenchChem offers custom synthesis for rare earth carbides and specific isotopic labeling.

Email: info@benchchem.com or [Request Quote Online](#).

Sources

- 1. [peptide.com](https://www.peptide.com) [peptide.com]
- 2. [N-Boc-L-phenylalanine, 99% | Fisher Scientific](https://www.fishersci.ca) [fishersci.ca]
- 3. [benchchem.com](https://www.benchchem.com) [benchchem.com]
- 4. [peptide.com](https://www.peptide.com) [peptide.com]
- 5. [benchchem.com](https://www.benchchem.com) [benchchem.com]
- 6. [medchemexpress.com](https://www.medchemexpress.com) [medchemexpress.com]

- [7. researchgate.net \[researchgate.net\]](https://www.researchgate.net)
- [8. The case of triethylammonium cation loss during purification of certain nucleotide analogues: a cautionary note - PMC \[pmc.ncbi.nlm.nih.gov\]](https://pubmed.ncbi.nlm.nih.gov/)
- To cite this document: BenchChem. [Technical Support Center: Boc-Phe-OH Solubility & Reaction Setup]. BenchChem, [2026]. [Online PDF]. Available at: [\[https://www.benchchem.com/product/b558496/docs#technical-support-center-boc-phe-oh-solubility-reaction-setup\]](https://www.benchchem.com/product/b558496/docs#technical-support-center-boc-phe-oh-solubility-reaction-setup)

Disclaimer & Data Validity:

The information provided in this document is for Research Use Only (RUO) and is strictly not intended for diagnostic or therapeutic procedures. While BenchChem strives to provide accurate protocols, we make no warranties, express or implied, regarding the fitness of this product for every specific experimental setup.

Technical Support: The protocols provided are for reference purposes. Unsure if this reagent suits your experiment?

Need Industrial/Bulk Grade? [Request Custom Synthesis Quote](#)

BenchChem

Our mission is to be the trusted global source of essential and advanced chemicals, empowering scientists and researchers to drive progress in science and industry.

Contact

Address: 3281 E Guasti Rd
Ontario, CA 91761, United States
Phone: (601) 213-4426
Email: info@benchchem.com

[Contact our Ph.D. Support Team for a compatibility check](#)

