

# Effect of base on Boc-Phe-OSu coupling efficiency

**Author:** BenchChem Technical Support Team. **Date:** May 2026

## Compound of Interest

Compound Name: *Boc-Phe-OSu*

CAS No.: 3674-06-4

Cat. No.: B558231

[Get Quote](#)

## Technical Support Center: Boc-Phe-OSu Coupling

Prepared by the Office of the Senior Application Scientist

Welcome to the technical support center for peptide synthesis. This guide provides in-depth troubleshooting and practical advice on the critical role of organic bases in optimizing the coupling efficiency of N- $\alpha$ -Boc-L-phenylalanine N-hydroxysuccinimide ester (**Boc-Phe-OSu**). Designed for researchers, chemists, and drug development professionals, this document moves beyond simple protocols to explain the chemical principles governing success, helping you diagnose issues and enhance your synthetic outcomes.

### Core Principles: The Mechanism and the Pivotal Role of the Base

In peptide synthesis, the formation of an amide bond is the fundamental step.<sup>[1]</sup> Using an activated ester like **Boc-Phe-OSu** is a common strategy where the N-hydroxysuccinimide

(OSu) moiety acts as an excellent leaving group, facilitating nucleophilic attack by a free amino group.<sup>[2][3]</sup>

The reaction's success, however, is not guaranteed by the activated ester alone. The nucleophile—the N-terminal amine of an amino acid or peptide—is often stored as a salt (e.g., hydrochloride or trifluoroacetate salt) to improve stability and handling. In this protonated form (R-NH<sub>3</sub><sup>+</sup>), the amine is not nucleophilic. The primary role of an organic base is to deprotonate this ammonium salt, liberating the free amine (R-NH<sub>2</sub>) to initiate the coupling reaction.<sup>[4][5]</sup>

The choice and application of the base are therefore critical, as it directly influences a delicate equilibrium:

- **Maximizing Nucleophilicity:** The base must be strong enough to efficiently deprotonate the amine, ensuring a sufficient concentration of the reactive nucleophile.<sup>[5]</sup>
- **Minimizing Side Reactions:** The base itself should be non-nucleophilic to avoid competing with the desired reaction. Furthermore, it must not promote unwanted side reactions, the most significant of which are hydrolysis of the active ester and racemization of the chiral amino acid center.<sup>[1][6][7]</sup>

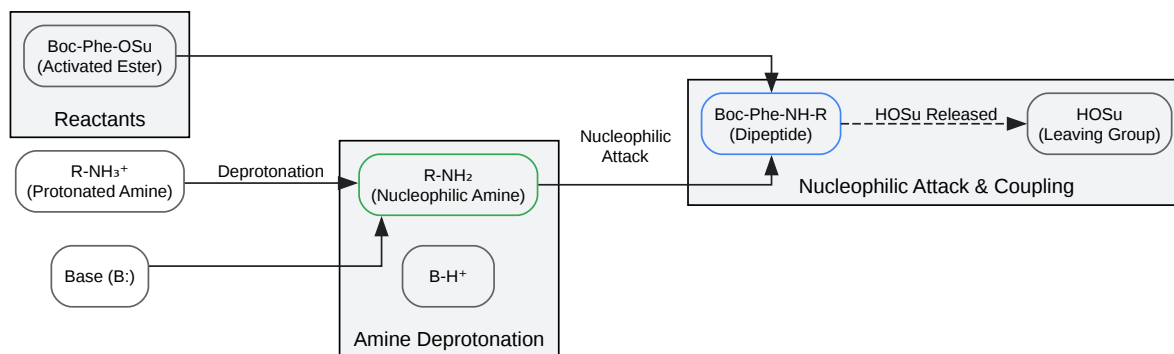

Figure 1: Role of Base in Boc-Phe-OSu Coupling

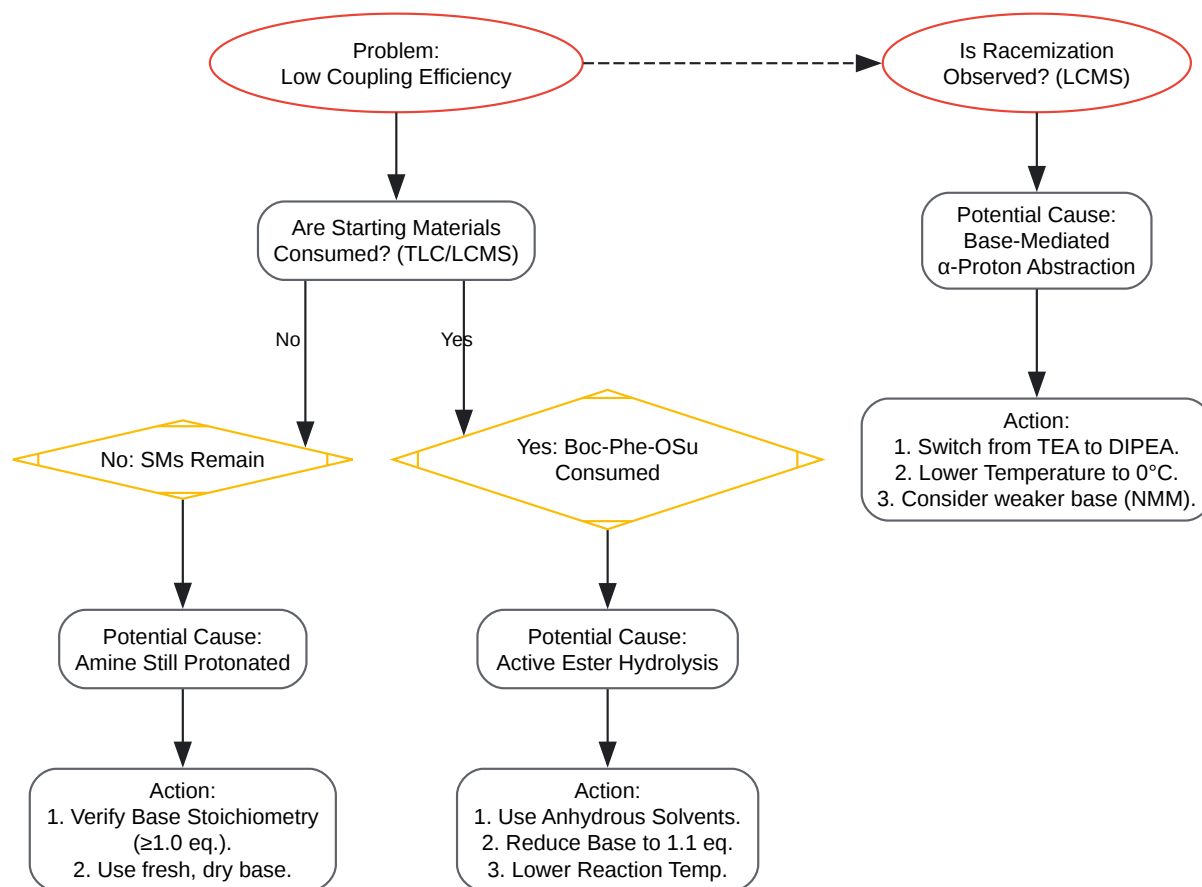

Figure 2: Troubleshooting Workflow for Low Coupling Efficiency

[Click to download full resolution via product page](#)

Figure 2: Troubleshooting Workflow for Low Coupling Efficiency

## Experimental Protocols

### Protocol 1: Standard Solution-Phase Coupling of **Boc-Phe-OSu**

This protocol describes a standard procedure for coupling **Boc-Phe-OSu** to an amino acid methyl ester hydrochloride salt (e.g., H-Gly-OMe·HCl).

Materials:

- **Boc-Phe-OSu** (1.0 eq.)

- Amino acid ester hydrochloride (e.g., H-Gly-OMe·HCl, 1.0 eq.)
- N,N-Diisopropylethylamine (DIPEA, 1.1 eq.)
- Anhydrous Dichloromethane (DCM) or Dimethylformamide (DMF)
- Standard glassware for organic synthesis (round-bottom flask, magnetic stirrer, etc.)

#### Procedure:

- Preparation of Amine Solution:
  - To a clean, dry round-bottom flask under an inert atmosphere (N<sub>2</sub> or Argon), add the amino acid ester hydrochloride salt (1.0 eq.).
  - Dissolve the salt in anhydrous DCM (or DMF) to a concentration of approximately 0.1 M.
  - Cool the solution to 0 °C in an ice-water bath.
- Amine Deprotonation:
  - While stirring the cooled amine solution, add DIPEA (1.1 eq.) dropwise via syringe.
  - Allow the solution to stir at 0 °C for 2 minutes. Do not wait longer than 5 minutes.
- Coupling Reaction:
  - In a separate flask, dissolve **Boc-Phe-OSu** (1.0 eq.) in a minimal amount of anhydrous DCM.
  - Add the **Boc-Phe-OSu** solution dropwise to the stirring amine solution at 0 °C.
  - Allow the reaction to slowly warm to room temperature and stir for 4-12 hours. The reaction progress should be monitored by TLC or LC-MS.
- Work-up and Purification:
  - Once the reaction is complete, dilute the mixture with additional DCM.

- Wash the organic layer sequentially with 5% aqueous citric acid (to remove excess base), saturated aqueous sodium bicarbonate (to remove unreacted starting acid and HOSu), and finally with brine.
- Dry the organic layer over anhydrous sodium sulfate ( $\text{Na}_2\text{SO}_4$ ), filter, and concentrate under reduced pressure.
- The crude product can then be purified by flash column chromatography on silica gel to yield the pure dipeptide.

## References

- Reddit User Discussion. (2022). Low yield in peptide coupling reaction using N-hydroxysuccinimide ester. r/Chempros. [\[Link\]](#)
- Jankolovits, J. (2006). Studying pH Dependence of a Peptide Modification with an N-hydroxysuccinimide Ester Using Mass Spectrometry. Journal of Young Investigators. [\[Link\]](#)
- Xinggao Chemical. (2025). What Is The Difference between Triethylamine And DIPEA?. Xinggao Chemical. [\[Link\]](#)
- ResearchGate Discussion. (2018). Can I use triethylamine instead of N,N-Diisopropylethylamine for acylation of a secondary amine? ResearchGate. [\[Link\]](#)
- Reddit User Discussion. (2023). Does using DIPEA in a peptide coupling reaction that different from TEA? r/chemistry. [\[Link\]](#)
- Bocom. (n.d.). A Brief Introduction to the Racemization of Amino Acids in Polypeptide Synthesis. Bocom. [\[Link\]](#)
- Ibsen, S., et al. (2018). pH Dependence of Succinimide-Ester-Based Protein Cross-Linking for Structural Mass Spectrometry Applications. Journal of the American Society for Mass Spectrometry. [\[Link\]](#)
- Royal Society of Chemistry. (2015). Quantification of N-hydroxysuccinimide and N-hydroxysulfosuccinimide by hydrophilic interaction chromatography (HILIC). Analytical Methods. [\[Link\]](#)

- Thieme. (n.d.). 7.4 Racemization Assays. Thieme Chemistry. [\[Link\]](#)
- Askenasy, G. (2019). Introduction to Peptide Synthesis. Master Organic Chemistry. [\[Link\]](#)

### Need Custom Synthesis?

BenchChem offers custom synthesis for rare earth carbides and specific isotopic labeling.

Email: [info@benchchem.com](mailto:info@benchchem.com) or [Request Quote Online](#).

## Sources

- [1. bachem.com](https://www.bachem.com) [[bachem.com](https://www.bachem.com)]
- [2. pdf.benchchem.com](https://pdf.benchchem.com) [[pdf.benchchem.com](https://pdf.benchchem.com)]
- [3. Buy Boc-Phe-OSu | 3674-06-4](https://smolecule.com) [[smolecule.com](https://smolecule.com)]
- [4. Studying pH Dependence of a Peptide Modification with an N-hydroxysuccinimide Ester Using Mass Spectrometry — Journal of Young Investigators](#) [[jyi.org](https://www.jyi.org)]
- [5. pdf.benchchem.com](https://pdf.benchchem.com) [[pdf.benchchem.com](https://pdf.benchchem.com)]
- [6. reddit.com](https://www.reddit.com) [[reddit.com](https://www.reddit.com)]
- [7. reddit.com](https://www.reddit.com) [[reddit.com](https://www.reddit.com)]
- To cite this document: BenchChem. [Effect of base on Boc-Phe-OSu coupling efficiency]. BenchChem, [2026]. [Online PDF]. Available at: [\[https://www.benchchem.com/product/b558231/docs#effect-of-base-on-boc-phe-osu-coupling-efficiency\]](https://www.benchchem.com/product/b558231/docs#effect-of-base-on-boc-phe-osu-coupling-efficiency)

---

### Disclaimer & Data Validity:

The information provided in this document is for Research Use Only (RUO) and is strictly not intended for diagnostic or therapeutic procedures. While BenchChem strives to provide accurate protocols, we make no warranties, express or implied, regarding the fitness of this product for every specific experimental setup.

**Technical Support:** The protocols provided are for reference purposes. Unsure if this reagent suits your experiment?

**Need Industrial/Bulk Grade?** [Request Custom Synthesis Quote](#)

## BenchChem

Our mission is to be the trusted global source of essential and advanced chemicals, empowering scientists and researchers to drive progress in science and industry.

### Contact

Address: 3281 E Guasti Rd  
Ontario, CA 91761, United States  
Phone: (601) 213-4426  
Email: [info@benchchem.com](mailto:info@benchchem.com)

[Contact our Ph.D. Support Team for a compatibility check](#)