

Technical Support Center: Optimizing Fmoc Deprotection for Sterically Hindered β -Homoproline

Author: BenchChem Technical Support Team. **Date:** May 2026

Compound of Interest

Compound Name: *Fmoc-L-beta-homoproline*

CAS No.: 193693-60-6

Cat. No.: B557515

[Get Quote](#)

Welcome to the technical support center for optimizing the $N\alpha$ -Fmoc deprotection of sterically hindered β -homoproline residues in solid-phase peptide synthesis (SPPS). This guide is designed for researchers, scientists, and drug development professionals, providing in-depth troubleshooting advice, answers to frequently asked questions, and detailed experimental protocols to overcome challenges associated with this demanding synthetic step.

Troubleshooting Guide

This section addresses specific issues you may encounter during the Fmoc deprotection of β -homoproline and offers targeted solutions.

Problem 1: Incomplete Fmoc Deprotection

Symptom: After the deprotection step, analytical HPLC/MS of a cleaved resin sample shows a significant peak corresponding to the Fmoc-protected peptide, or a positive Kaiser test is not observed.

Potential Causes & Solutions:

- **Steric Hindrance:** The rigid, cyclic structure of β -homoproline, combined with the bulkiness of the Fmoc group, can physically block the approach of the deprotection base.[1] This is often the primary reason for incomplete deprotection.
 - **Solution 1: Extend Deprotection Time:** Increase the standard deprotection time. For example, instead of a single 10-minute treatment, try two treatments of 15-20 minutes each.[2]
 - **Solution 2: Use a Stronger, Less Hindered Base:** Standard piperidine may be too bulky. Consider using a stronger, non-nucleophilic base like 1,8-Diazabicyclo[5.4.0]undec-7-ene (DBU).[3][4] A common cocktail is 2% DBU in a 20% piperidine/DMF solution.[1][2] The piperidine is still necessary to scavenge the dibenzofulvene (DBF) byproduct.[3][4]
 - **Solution 3: Increase Temperature:** Gently heating the reaction can increase the kinetic energy and overcome the activation barrier. Microwave-assisted SPPS can be particularly effective, raising the temperature to around 90°C for a short period (e.g., 1 minute).[2] However, this must be carefully optimized to avoid side reactions.
- **Peptide Aggregation:** As the peptide chain elongates, it can form secondary structures on the resin, limiting solvent and reagent accessibility.[1][2]
 - **Solution 1: Change the Solvent:** Switch from DMF to N-methylpyrrolidone (NMP), which is known to be better at disrupting peptide aggregation.[2]
 - **Solution 2: Use Chaotropic Salts:** Adding chaotropic salts like LiCl to the deprotection solution can help break up secondary structures.

Problem 2: Side Reactions During Deprotection

Symptom: HPLC/MS analysis reveals unexpected peaks, indicating the formation of byproducts.

Potential Causes & Solutions:

- Diketopiperazine (DKP) Formation: This is a common side reaction, especially at the dipeptide stage, and can be promoted by strong bases.[5]
 - Solution: Use a Milder Base or Modified Conditions: If DKP formation is a significant issue, consider using a less aggressive deprotection cocktail. Lowering the piperidine concentration to 5-10% can be effective.[2] Alternatively, a combination of 5% piperazine with 2% DBU has been shown to reduce DKP formation in some cases.[5][6]
- Aspartimide Formation: If your sequence contains aspartic acid residues, strong bases like DBU can catalyze the formation of aspartimide, a common and problematic side reaction.[3][4][7]
 - Solution: Avoid DBU with Aspartic Acid: If your peptide contains Asp, it is best to avoid DBU. Stick with extended piperidine treatments or consider alternative bases like piperazine.[7]

Frequently Asked Questions (FAQs)

Q1: Why is Fmoc deprotection of β -homoproline so challenging?

The primary challenge lies in the steric hindrance imparted by the cyclic structure of β -homoproline. This five-membered ring restricts the conformational flexibility around the N-terminus, making it difficult for the base (typically piperidine) to access and abstract the acidic proton on the fluorenyl group of the Fmoc protecting group.[1][8] This steric hindrance slows down the deprotection reaction, often leading to incomplete removal of the Fmoc group under standard conditions.

Q2: What is the mechanism of Fmoc deprotection?

Fmoc deprotection proceeds via a two-step E1cB (Elimination, Unimolecular, conjugate Base) mechanism.[7] First, a base abstracts the acidic proton from the 9-position of the fluorene ring. This is the rate-determining step.[7] The resulting carbanion is unstable and undergoes β -elimination, releasing the free amine of the peptide, carbon dioxide, and a reactive intermediate called dibenzofulvene (DBF). The secondary amine in the deprotection solution (e.g., piperidine) then acts as a scavenger, trapping the DBF to form a stable adduct that is washed away.[8][9]

Q3: How can I monitor the completeness of the deprotection reaction?

There are several methods to monitor Fmoc deprotection:

- **UV-Vis Spectrophotometry:** The DBF-piperidine adduct has a characteristic UV absorbance at around 301-302 nm.[\[9\]](#) By monitoring the increase in absorbance of the deprotection solution over time, you can quantify the extent of Fmoc removal.
- **HPLC and Mass Spectrometry:** This is the most definitive method. A small sample of the resin can be cleaved and analyzed by HPLC-MS to check for the presence of any remaining Fmoc-protected peptide.[\[10\]](#)
- **Kaiser Test:** This colorimetric test detects the presence of free primary amines.[\[1\]](#) A positive result (blue color) indicates that the Fmoc group has been successfully removed. However, it is not quantitative and may not be reliable for N-terminal proline residues.

Q4: Are there alternatives to piperidine for Fmoc deprotection?

Yes, several alternatives to piperidine have been explored to address issues like slow deprotection, side reactions, and regulatory concerns.[\[11\]](#) Some common alternatives are summarized in the table below:

Deprotection Reagent	Recommended Concentration & Solvent	Key Advantages	Potential Disadvantages
Piperidine	20% (v/v) in DMF or NMP	Well-established and effective for most amino acids.[12][13]	Can be slow for hindered residues and may promote side reactions.[1][8]
1,8-Diazabicyclo[5.4.0]undec-7-ene (DBU)	2% (v/v) DBU + 20% (v/v) piperidine in DMF	Much faster deprotection than piperidine alone.[3][4]	Strong base that can catalyze side reactions like aspartimide formation. [3][4]
Piperazine	5% (w/v) Piperazine + 2% (v/v) DBU in DMF/NMP	A rapid and effective alternative to piperidine that may reduce certain side reactions.[1][7]	Requires the use of DBU for optimal speed.
Pyrrolidine	20% (v/v) in various solvents	Can be more effective than piperidine in less polar solvents.[14][15]	May require solvent optimization.
4-Methylpiperidine (4-MP)	20% (v/v) in DMF	Similar performance to piperidine.[16]	Offers no significant advantage over piperidine for hindered residues.

Q5: What is the role of the solvent in Fmoc deprotection?

The solvent plays a crucial role in swelling the resin, solvating the peptide chain, and facilitating the diffusion of the deprotection reagent.[11] DMF and NMP are the most common solvents due to their high polarity and ability to disrupt peptide aggregation.[13][16] The choice of solvent can significantly impact the efficiency of the deprotection reaction, especially for difficult sequences.[14]

Experimental Protocols

Protocol 1: Standard Fmoc Deprotection with Extended Treatment

This protocol is a good starting point for moderately hindered residues.

- Resin Swelling: Swell the peptide-resin in DMF for at least 30 minutes.
- First Deprotection: Drain the solvent and add a solution of 20% piperidine in DMF, ensuring the resin is fully submerged. Agitate for 15-30 minutes.[1]
- Drain and Wash: Drain the deprotection solution. Wash the resin with DMF (2 times).[1]
- Second Deprotection: Add a fresh solution of 20% piperidine in DMF and agitate for another 15-30 minutes.[1]
- Final Wash: Drain the solution and wash the resin thoroughly with DMF (at least 5-7 times) to remove all residual piperidine and the dibenzofulvene adduct.[1]

Protocol 2: DBU-Catalyzed Fmoc Deprotection

This protocol is recommended for highly hindered residues where standard conditions fail.

Caution: Do not use this protocol if your peptide contains aspartic acid.[3][4]

- Resin Swelling and Wash: Follow steps 1 and 2 from the standard protocol.
- Deprotection: Treat the resin with a solution of 2% (v/v) DBU and 20% (v/v) piperidine in DMF for 5-10 minutes.[2]
- Drain and Repeat: Drain the solution and repeat the treatment for another 5-10 minutes.[2]
- Washing: Wash the resin thoroughly with DMF (7-10 times) to ensure all traces of the strong base are removed before the next coupling step.[1]

Visualizations

Fmoc Deprotection Mechanism

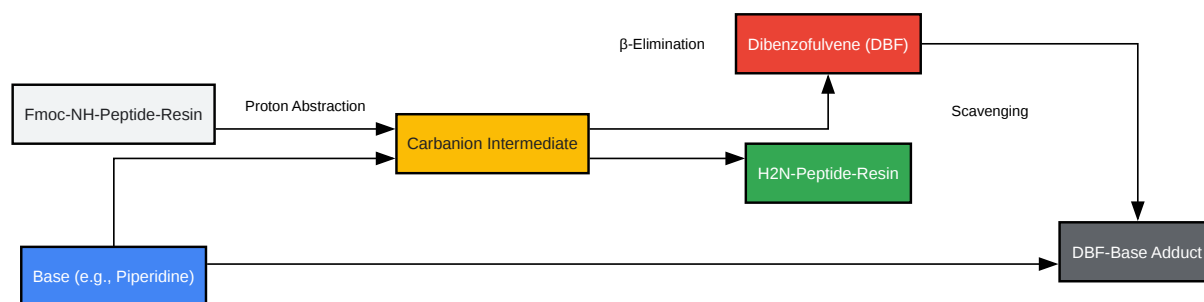

[Click to download full resolution via product page](#)

Caption: Mechanism of Fmoc deprotection by a basic reagent.

Troubleshooting Workflow

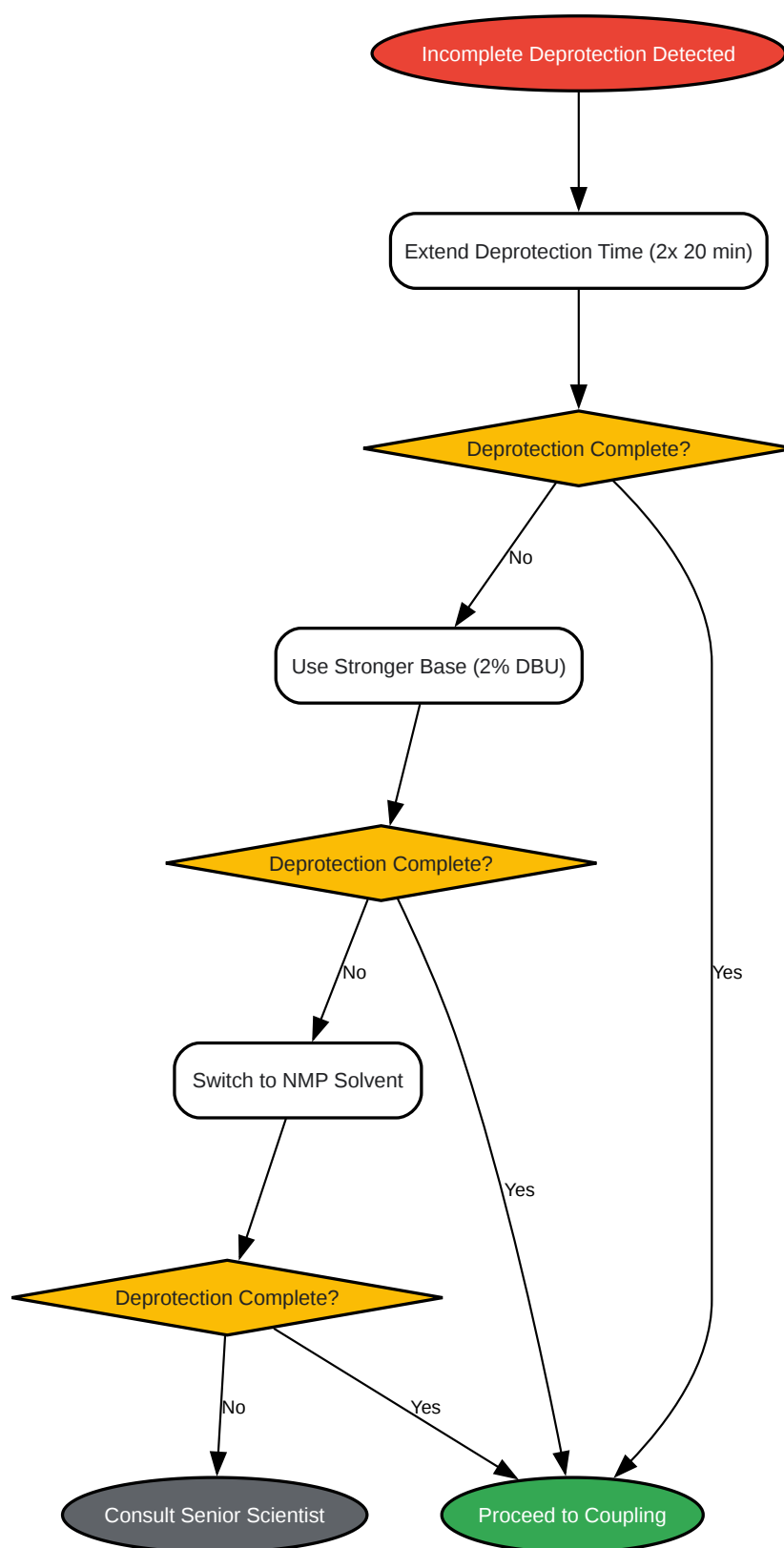

[Click to download full resolution via product page](#)

Caption: Decision tree for troubleshooting incomplete Fmoc deprotection.

References

- Aapptec Peptides. (n.d.). Technical Support Information Bulletin 1173 - Fmoc Removal with DBU.
- Aapptec Peptides. (n.d.). Technical Support Information Bulletin 1173.
- Benchchem. (2025). Application Notes and Protocols: Standard Conditions for Fmoc Group Removal with Piperidine in Solid-Phase Peptide Synthesis.
- UCI Chemistry. (n.d.). Standard practices for Fmoc-based solid-phase peptide synthesis in the Nowick laboratory (Version 1.7.2).
- National Institutes of Health. (n.d.). Deprotection Reagents in Fmoc Solid Phase Peptide Synthesis: Moving Away from Piperidine? - PMC.
- Sigma-Aldrich. (n.d.). Fmoc Resin Cleavage and Deprotection.
- SciELO México. (n.d.). Efficient Synthesis of Peptides with 4-Methylpiperidine as Fmoc Removal Reagent by Solid Phase Synthesis.
- Royal Society of Chemistry. (n.d.). . Retrieved from
- Benchchem. (2025). Troubleshooting incomplete Fmoc deprotection of His(Boc) residues.
- Benchchem. (2025). Technical Support Center: Optimizing Fmoc-Deprotection of Fmoc- β -HoAla(styryl)-OH.
- ResearchGate. (2025). Improved Preparation of Amyloid-?? Peptides Using DBU as N??-Fmoc Deprotection Reagent | Request PDF.
- American Chemical Society. (2024). Catalytic Cleavage of the 9-Fluorenylmethoxycarbonyl (Fmoc) Protecting Group under Neat Conditions.
- Royal Society of Chemistry. (n.d.). Green Chemistry - In situ Fmoc removal.
- ACS Sustainable Chemistry & Engineering. (2021). Fmoc-Removal with Pyrrolidine Expands the Available Solvent Space in Green Solid-Phase Peptide Synthesis.
- MDPI. (n.d.). Deprotection Reagents in Fmoc Solid Phase Peptide Synthesis: Moving Away from Piperidine?.
- ACS GCI Pharmaceutical Roundtable Reagent Guides. (2025). Deprotection - Wordpress.
- ResearchGate. (2021). Fmoc-Removal with Pyrrolidine Expands the Available Solvent Space in Green Solid-Phase Peptide Synthesis.
- CHIMIA. (n.d.). Thermal Cleavage of the Fmoc Protection Group.
- ResearchGate. (2025). (PDF) Methods for Removing the Fmoc Group.
- National Institutes of Health. (2022). Optimized Fmoc-Removal Strategy to Suppress the Traceless and Conventional Diketopiperazine Formation in Solid-Phase Peptide Synthesis - PMC.
- ScholarWorks@GVSU. (n.d.). Studies on the Effect of Lewis Acids on Fmoc Deprotection in Solution and Solid-Phase.

- ACS Publications. (2023). Dipropylamine for 9-Fluorenylmethyloxycarbonyl (Fmoc) Deprotection with Reduced Aspartimide Formation in Solid-Phase Peptide Synthesis | ACS Omega.
- Benchchem. (n.d.). Unveiling the Superior Deprotection Kinetics of Fmoc-Arg(MIS)-OH over Fmoc-Arg(Pbf)-OH in Peptide Synthesis.
- ResearchGate. (n.d.). Fmoc cleavage in different solvents after 15 min at 120 °C.
- ACS Publications. (2022). Optimized Fmoc-Removal Strategy to Suppress the Traceless and Conventional Diketopiperazine Formation in Solid-Phase Peptide Synthesis | ACS Omega.
- Sigma-Aldrich. (n.d.). Fmoc Resin Cleavage and Deprotection.
- Benchchem. (n.d.). Technical Support Center: Troubleshooting Incomplete Fmoc Deprotection of Sterically Hindered Residues.
- Aapptec Peptides. (n.d.). Amino Acid Sidechain Deprotection.
- Springer Nature Experiments. (n.d.). Methods for Removing the Fmoc Group.
- Benchchem. (2025). Protocol for Fmoc Deprotection of Pseudoproline Dipeptides in Solid-Phase Peptide Synthesis.
- Springer Protocols. (1995). Acid Cleavage/Deprotection in Fmoc/tBiu Solid-Phase Peptide Synthesis.
- Sigma-Aldrich. (n.d.). Protocols for the Fmoc SPPS of Cysteine-Containing Peptides.

Need Custom Synthesis?

BenchChem offers custom synthesis for rare earth carbides and specific isotopic labeling.

Email: info@benchchem.com or [Request Quote Online](#).

Sources

- [1. pdf.benchchem.com \[pdf.benchchem.com\]](https://pdf.benchchem.com)
- [2. pdf.benchchem.com \[pdf.benchchem.com\]](https://pdf.benchchem.com)
- [3. peptide.com \[peptide.com\]](https://peptide.com)
- [4. peptide.com \[peptide.com\]](https://peptide.com)
- [5. Optimized Fmoc-Removal Strategy to Suppress the Traceless and Conventional Diketopiperazine Formation in Solid-Phase Peptide Synthesis - PMC \[pmc.ncbi.nlm.nih.gov\]](https://pubs.ncbi.nlm.nih.gov)
- [6. pubs.acs.org \[pubs.acs.org\]](https://pubs.acs.org)
- [7. pubs.rsc.org \[pubs.rsc.org\]](https://pubs.rsc.org)

- [8. Efficient Synthesis of Peptides with 4-Methylpiperidine as Fmoc Removal Reagent by Solid Phase Synthesis \[scielo.org.mx\]](#)
- [9. pdf.benchchem.com \[pdf.benchchem.com\]](#)
- [10. chem.uci.edu \[chem.uci.edu\]](#)
- [11. Deprotection Reagents in Fmoc Solid Phase Peptide Synthesis: Moving Away from Piperidine? - PMC \[pmc.ncbi.nlm.nih.gov\]](#)
- [12. pdf.benchchem.com \[pdf.benchchem.com\]](#)
- [13. Methods for Removing the Fmoc Group | Springer Nature Experiments \[experiments.springernature.com\]](#)
- [14. pubs.acs.org \[pubs.acs.org\]](#)
- [15. researchgate.net \[researchgate.net\]](#)
- [16. Deprotection Reagents in Fmoc Solid Phase Peptide Synthesis: Moving Away from Piperidine? \[mdpi.com\]](#)
- To cite this document: BenchChem. [Technical Support Center: Optimizing Fmoc Deprotection for Sterically Hindered β -Homoproline]. BenchChem, [2026]. [Online PDF]. Available at: [<https://www.benchchem.com/product/b557515/docs#technical-support-center-optimizing-fmoc-deprotection-for-sterically-hindered-homoproline>]

Disclaimer & Data Validity:

The information provided in this document is for Research Use Only (RUO) and is strictly not intended for diagnostic or therapeutic procedures. While BenchChem strives to provide accurate protocols, we make no warranties, express or implied, regarding the fitness of this product for every specific experimental setup.

Technical Support: The protocols provided are for reference purposes. Unsure if this reagent suits your experiment?

Need Industrial/Bulk Grade? [Request Custom Synthesis Quote](#)

BenchChem

Our mission is to be the trusted global source of essential and advanced chemicals, empowering scientists and researchers to drive progress in science and industry.

Contact

Address: 3281 E Guasti Rd
Ontario, CA 91761, United States
Phone: (601) 213-4426
Email: info@benchchem.com

[Contact our Ph.D. Support Team for a compatibility check](#)