

# Technical Support Center: Optimizing FRET with 7-Methoxycoumarin-4-acetic acid

**Author:** BenchChem Technical Support Team. **Date:** May 2026

## Compound of Interest

Compound Name: 7-Methoxycoumarin-4-acetic acid

CAS No.: 62935-72-2

Cat. No.: B556899

[Get Quote](#)

This technical support center provides researchers, scientists, and drug development professionals with troubleshooting guides and frequently asked questions (FAQs) to enhance Förster Resonance Energy Transfer (FRET) efficiency when using **7-Methoxycoumarin-4-acetic acid** (M-4-A) as a donor fluorophore.

## Frequently Asked Questions (FAQs)

Q1: What is **7-Methoxycoumarin-4-acetic acid** (M-4-A) and why is it used as a FRET donor?

**7-Methoxycoumarin-4-acetic acid** (M-4-A), also known as MCA, is a blue-emitting fluorophore commonly used as a donor in FRET-based assays.<sup>[1][2]</sup> Its popularity stems from its relatively small size, which minimizes potential steric hindrance and perturbation of biomolecular function.<sup>[3][4]</sup> It has favorable photophysical properties for a FRET donor, including a good fluorescence quantum yield. M-4-A is typically excited in the UV or near-UV range (around 320-325 nm) and emits in the blue region of the spectrum (~380-400 nm).<sup>[5][6]</sup>

Q2: What are the ideal acceptor pairs for **7-Methoxycoumarin-4-acetic acid**?

The selection of an acceptor is critical and depends on significant spectral overlap between the M-4-A emission and the acceptor's absorption.<sup>[7][8]</sup> Commonly used and effective acceptor partners include:

- Dinitrophenyl (DNP) group: M-4-A is widely used in FRET pairs with DNP, which acts as a quencher.<sup>[2][5]</sup> This pair is often incorporated into peptide substrates for protease activity assays.
- Acridonylalanine (Acd): This unnatural amino acid is an excellent FRET acceptor for methoxycoumarin (Mcm), a derivative of M-4-A. The Mcm/Acd pair is well-suited for measuring intramolecular distances in the 15-40 Å range and offers the advantage of being minimally perturbing to protein structure.<sup>[3][4][9]</sup>
- Rhodamine and Fluorescein derivatives: Dyes like rhodamine and fluorescein can also serve as acceptors, though their larger size can sometimes be a disadvantage.<sup>[10][11]</sup> The choice depends on the required Förster distance and the specific experimental context.

Q3: What are the key factors that influence FRET efficiency?

FRET efficiency (E) is highly dependent on several factors:<sup>[7][12]</sup>

- Distance between Donor and Acceptor: The efficiency is inversely proportional to the sixth power of the distance between the donor and acceptor, making it a sensitive molecular ruler for distances typically in the 1-10 nm range.<sup>[7][8][12][13]</sup>
- Spectral Overlap: There must be significant overlap between the emission spectrum of the donor (M-4-A) and the absorption spectrum of the acceptor.<sup>[7][8]</sup>
- Dipole Orientation: The relative orientation of the donor's emission dipole and the acceptor's absorption dipole affects the energy transfer. Random or parallel orientations are more favorable than perpendicular ones.<sup>[7]</sup>
- Donor Quantum Yield and Acceptor Extinction Coefficient: A high quantum yield donor and a high extinction coefficient acceptor will generally result in better FRET efficiency.<sup>[8][14]</sup>

Below is a diagram illustrating the key factors influencing FRET efficiency.

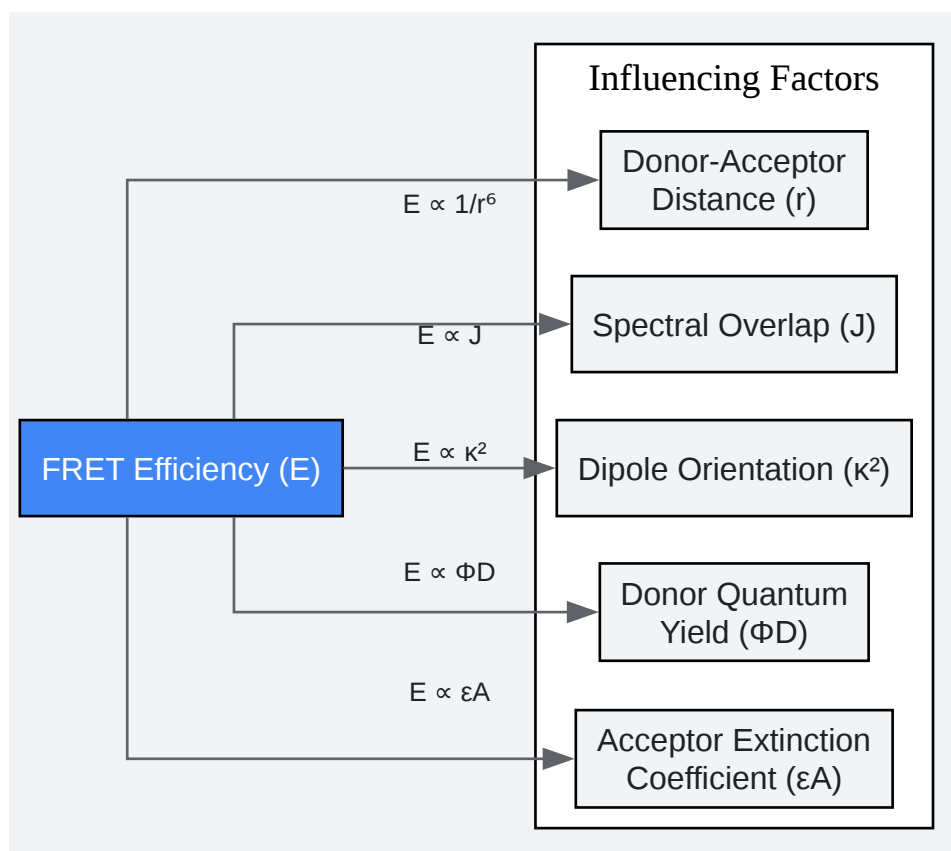

[Click to download full resolution via product page](#)

Caption: Key factors determining FRET efficiency.

## Troubleshooting Guide

Problem: Low or No FRET Efficiency Observed

This is a common issue that can arise from several sources. Follow this step-by-step guide to diagnose and resolve the problem.

Step 1: Verify Labeling and Stoichiometry

- Question: Is your molecule of interest (e.g., protein, peptide) correctly labeled with both the donor (M-4-A) and acceptor?
- Action:

- Confirm Labeling: Use mass spectrometry (e.g., MALDI-MS) to confirm the covalent attachment of both fluorophores.[9] An increase in mass corresponding to the fluorophores should be observed.
- Determine Stoichiometry: Use UV-Vis spectroscopy to determine the concentration of the molecule and the incorporated dyes. An ideal donor-to-acceptor stoichiometry is close to 1:1. A large excess of either donor or acceptor can mask the FRET signal.[15]

### Step 2: Check Spectroscopic Properties and Instrument Settings

- Question: Are your instrument settings and buffer conditions optimal for the M-4-A FRET pair?
- Action:
  - Measure Individual Spectra: Record the absorption and emission spectra of the donor-only and acceptor-only labeled molecules. Confirm that the emission spectrum of M-4-A overlaps with the absorption spectrum of your chosen acceptor.[8]
  - Optimize Instrument Settings: Ensure the excitation wavelength is set to the absorbance maximum of M-4-A (~320-325 nm).[5] Set the emission detection window to capture both the donor and acceptor fluorescence.
  - Control for Background: Subtract the fluorescence of an unlabeled sample and buffer from your measurements.

### Step 3: Evaluate Structural and Environmental Factors

- Question: Could the distance or orientation between the donor and acceptor be unfavorable for FRET?
- Action:
  - Re-evaluate Labeling Sites: The distance between the labeling sites might be too large (>10 nm). If possible, model the structure of your biomolecule to estimate the distance. Consider alternative labeling sites to bring the fluorophores closer.

- Consider Linker Length: The linkers used to attach the fluorophores can affect their distance and mobility. A linker that is too long or too rigid might prevent the dyes from coming into close proximity.[\[10\]](#)
- Assess Environmental Effects: Changes in pH, temperature, or solvent polarity can alter the photophysical properties of the fluorophores and the conformation of the biomolecule, thereby affecting FRET. Ensure your experimental conditions are consistent.

The following workflow can guide your troubleshooting process.

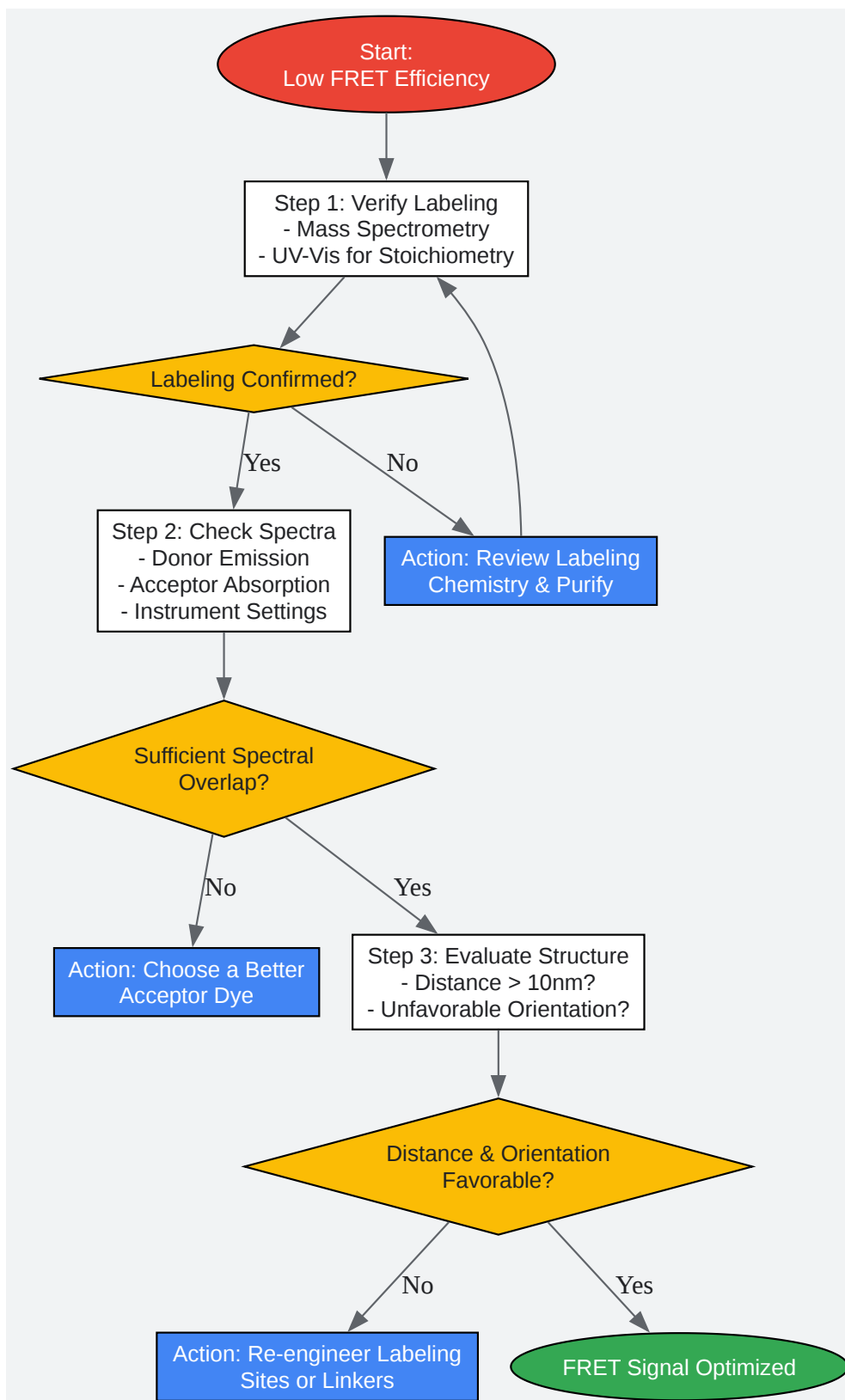

[Click to download full resolution via product page](#)

Caption: Troubleshooting workflow for low FRET efficiency.

## Quantitative Data for M-4-A FRET Pairs

The following tables summarize the key photophysical properties of **7-Methoxycoumarin-4-acetic acid** and potential acceptor dyes. The Förster Distance ( $R_0$ ) is the distance at which FRET efficiency is 50% and is a critical parameter for designing FRET experiments.

Table 1: Photophysical Properties of Donor (**7-Methoxycoumarin-4-acetic acid**)

Property	Value	Reference
Absorption Max ( $\lambda_{abs}$ )	~320 nm	[5]
Emission Max ( $\lambda_{em}$ )	~380 nm	[5]
Molar Extinction Coeff. ( $\epsilon$ )	~18,000 M <sup>-1</sup> cm <sup>-1</sup>	Estimated value
Fluorescence Quantum Yield ( $\Phi_D$ )	~0.4 - 0.7	Estimated value

Table 2: Potential Acceptor Pairs and Calculated Förster Distances ( $R_0$ )

Acceptor Dye	Absorption Max ( $\lambda_{abs}$ )	Förster Distance ( $R_0$ )	Notes
Dinitrophenyl (DNP)	~360 nm	~20 - 30 Å	Acts as a dark quencher. $R_0$ depends on the specific DNP derivative.
Acridonylalanine (Acd)	~385 nm	~15 - 40 Å	Minimally perturbing unnatural amino acid. [3][9]
Fluorescein (FITC)	~494 nm	~30 - 45 Å	Significant spectral overlap, but larger size.
Rhodamine B	~555 nm	Not a suitable pair	Poor spectral overlap with M-4-A emission.

Note:  $R_0$  values are estimates and can vary based on the specific molecular environment, linker, and dipole orientation ( $\kappa^2$ ).

## Experimental Protocols

### Protocol 1: Covalent Labeling of a Protein with M-4-A Succinimidyl Ester

This protocol describes the labeling of a protein's primary amines (N-terminus and lysine side chains) with an amine-reactive derivative of M-4-A.

#### Materials:

- Protein of interest in an amine-free buffer (e.g., PBS, pH 7.2-8.0)
- **7-Methoxycoumarin-4-acetic acid**, succinimidyl ester (M-4-A, SE)
- Anhydrous Dimethylformamide (DMF) or Dimethyl sulfoxide (DMSO)
- Size-exclusion chromatography column (e.g., Sephadex G-25)

#### Procedure:

- **Prepare Protein Solution:** Dissolve the protein in the reaction buffer at a concentration of 1-10 mg/mL.
- **Prepare Dye Stock Solution:** Immediately before use, dissolve the M-4-A, SE in DMF or DMSO to a concentration of 10 mg/mL.
- **Labeling Reaction:** While gently vortexing the protein solution, add a 5- to 20-fold molar excess of the reactive dye stock solution.
- **Incubation:** Incubate the reaction mixture for 1-2 hours at room temperature, protected from light.
- **Purification:** Separate the labeled protein from the unreacted dye using a size-exclusion chromatography column pre-equilibrated with a suitable storage buffer. The labeled protein will elute first.

- Characterization: Determine the degree of labeling by measuring the absorbance of the purified protein at 280 nm and M-4-A at ~320 nm.

#### Protocol 2: Measuring FRET Efficiency via Steady-State Fluorescence

This protocol outlines the measurement of FRET efficiency by comparing the donor's fluorescence in the presence and absence of the acceptor.

#### Materials:

- Donor-only labeled sample (D-only)
- Acceptor-only labeled sample (A-only)
- Donor-Acceptor labeled sample (FRET sample)
- Spectrofluorometer

#### Procedure:

- Sample Preparation: Prepare solutions of the D-only, A-only, and FRET samples at the same molar concentration in the assay buffer. The absorbance at the donor excitation wavelength should be kept below 0.1 to minimize inner-filter effects.
- Acquire Donor Emission Spectrum:
  - Place the D-only sample in the spectrofluorometer.
  - Excite the sample at the M-4-A absorption maximum (~320 nm).
  - Record the emission spectrum from ~340 nm to 600 nm. The peak intensity is  $F_D$ .
- Acquire FRET Sample Emission Spectrum:
  - Place the FRET sample in the spectrofluorometer.
  - Using the same instrument settings, excite the sample at ~320 nm.

- Record the emission spectrum over the same range. The donor's peak intensity in the presence of the acceptor is  $F_{DA}$ .
- Calculate FRET Efficiency (E):
  - Use the following formula:  $E = 1 - (F_{DA} / F_D)$ <sup>[16]</sup>
  - Where  $F_{DA}$  is the fluorescence intensity of the donor in the FRET sample, and  $F_D$  is the fluorescence intensity of the donor in the D-only sample.

The workflow for a typical FRET experiment is visualized below.

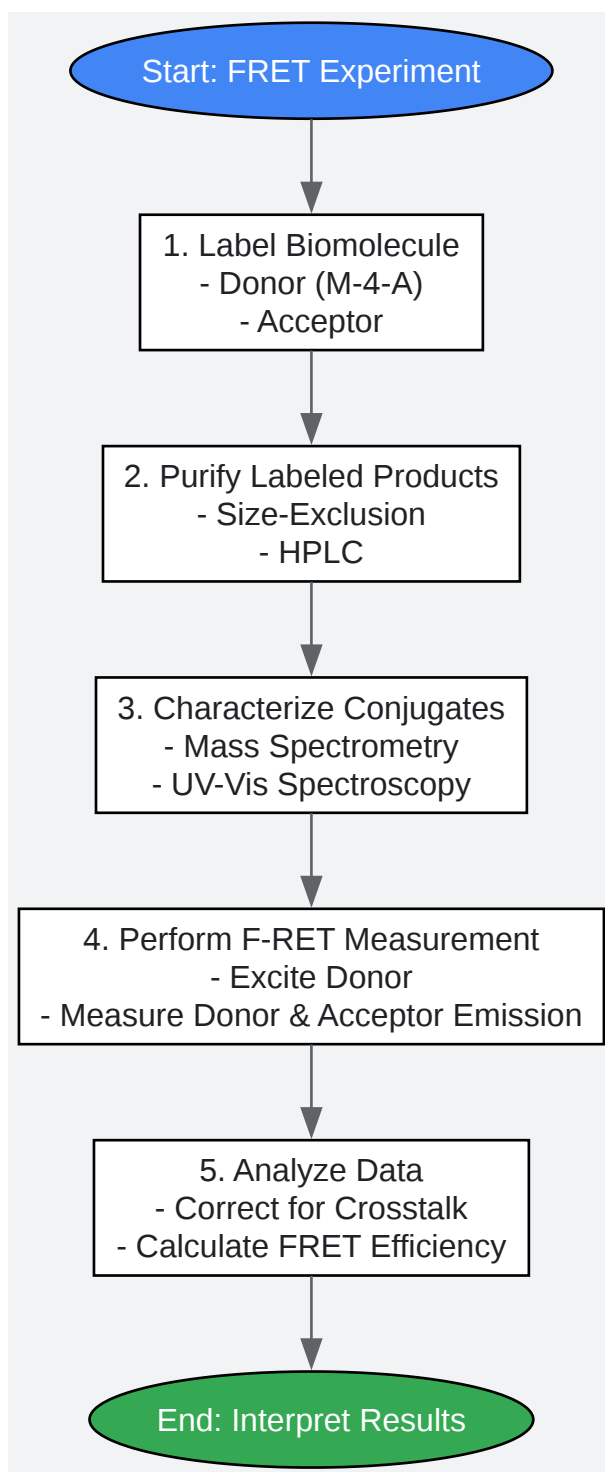

[Click to download full resolution via product page](#)

Caption: General experimental workflow for FRET.

### Need Custom Synthesis?

BenchChem offers custom synthesis for rare earth carbides and specific isotopic labeling.

Email: [info@benchchem.com](mailto:info@benchchem.com) or [Request Quote Online](#).

## References

- [1. medchemexpress.com \[medchemexpress.com\]](https://www.medchemexpress.com)
- [2. MCA \[7-Methoxycoumarin-4-acetic acid\] \\*CAS 62935-72-2\\* | AAT Bioquest \[aatbio.com\]](#)
- [3. Protein Labeling for FRET with Methoxycoumarin and Acridonylalanine - PMC \[pmc.ncbi.nlm.nih.gov\]](#)
- [4. Protein labeling for FRET with methoxycoumarin and acridonylalanine - PubMed \[pubmed.ncbi.nlm.nih.gov\]](#)
- [5. Mca \(7-Methoxycoumarin-4-acetic acid\) - 1 g \[anaspec.com\]](#)
- [6. benchchem.com \[benchchem.com\]](https://www.benchchem.com)
- [7. What factors can influence FRET efficiency? | AAT Bioquest \[aatbio.com\]](#)
- [8. FRET Building Blocks | AAT Bioquest \[aatbio.com\]](#)
- [9. Multicolor Protein FRET with Tryptophan, Selective Coumarin-Cysteine Labeling, and Genetic Acridonylalanine Encoding - PMC \[pmc.ncbi.nlm.nih.gov\]](#)
- [10. researchgate.net \[researchgate.net\]](https://www.researchgate.net)
- [11. Förster resonance energy transfer \(FRET\)-based small-molecule sensors and imaging agents - PMC \[pmc.ncbi.nlm.nih.gov\]](#)
- [12. Förster resonance energy transfer - Wikipedia \[en.wikipedia.org\]](#)
- [13. dash.harvard.edu \[dash.harvard.edu\]](https://dash.harvard.edu)
- [14. Basics of FRET Microscopy | Nikon's MicroscopyU \[microscopyu.com\]](#)
- [15. What are the factors that affect FRET measurements? | AAT Bioquest \[aatbio.com\]](#)
- [16. benchchem.com \[benchchem.com\]](https://www.benchchem.com)
- To cite this document: BenchChem. [Technical Support Center: Optimizing FRET with 7-Methoxycoumarin-4-acetic acid]. BenchChem, [2026]. [Online PDF]. Available at: [\[https://www.benchchem.com/product/b556899/docs#technical-support-center-optimizing-fret-with-7-methoxycoumarin-4-acetic-acid\]](https://www.benchchem.com/product/b556899/docs#technical-support-center-optimizing-fret-with-7-methoxycoumarin-4-acetic-acid)

**Disclaimer & Data Validity:**

The information provided in this document is for Research Use Only (RUO) and is strictly not intended for diagnostic or therapeutic procedures. While BenchChem strives to provide accurate protocols, we make no warranties, express or implied, regarding the fitness of this product for every specific experimental setup.

**Technical Support:** The protocols provided are for reference purposes. Unsure if this reagent suits your experiment?

**Need Industrial/Bulk Grade?** [Request Custom Synthesis Quote](#)

## BenchChem

Our mission is to be the trusted global source of essential and advanced chemicals, empowering scientists and researchers to drive progress in science and industry.

### Contact

Address: 3281 E Guasti Rd  
Ontario, CA 91761, United States  
Phone: (601) 213-4426  
Email: [info@benchchem.com](mailto:info@benchchem.com)

[Contact our Ph.D. Support Team for a compatibility check](#)