

Best practices for handling and storing 4-fluoro-L-phenylalanine

Author: BenchChem Technical Support Team. **Date:** December 2025

Compound of Interest

Compound Name: 4-fluoro-L-phenylalanine

Cat. No.: B556548

[Get Quote](#)

Technical Support Center: 4-Fluoro-L-phenylalanine

This technical support center provides best practices, troubleshooting guides, and frequently asked questions for handling and storing **4-fluoro-L-phenylalanine**. It is intended for researchers, scientists, and drug development professionals.

Summary of Quantitative Data

For quick reference, the following table summarizes the key quantitative data for **4-fluoro-L-phenylalanine**.

Property	Value	Citations
Molecular Formula	C ₉ H ₁₀ FNO ₂	[1]
Molecular Weight	183.18 g/mol	[1]
Appearance	White to off-white powder or crystals.	[1][2]
Melting Point	~240-255 °C (decomposes)	[1][3]
Storage Temperature	Room temperature, 0-8°C, or -20°C. Keep in a dark, dry, and well-ventilated place.	[2][3][4]
Stability	Stable under recommended storage conditions for at least 4 years. May be light-sensitive.	[4][5]
Solubility	Soluble in water, 0.5M HCl (50 mg/ml), PBS (pH 7.2) (5 mg/ml), and DMSO (55 mg/mL). Also soluble in chloroform, dichloromethane, ethyl acetate, and acetone.	[3][4][6][7]
Purity	≥ 99% (HPLC, Chiral HPLC)	[2]

Frequently Asked Questions (FAQs)

Handling and Storage

Q1: What are the recommended storage conditions for **4-fluoro-L-phenylalanine**?

A1: **4-fluoro-L-phenylalanine** should be stored in a tightly sealed container in a dry, cool, and well-ventilated place.[1] For long-term storage, temperatures of -20°C are recommended, and the compound is stable for at least four years under these conditions.[4] Some suppliers recommend storage at 0-8°C or even room temperature for shorter periods.[2][3] It is also advised to protect it from light.[5][8]

Q2: What personal protective equipment (PPE) should be worn when handling **4-fluoro-L-phenylalanine**?

A2: Standard laboratory PPE should be worn, including safety glasses or goggles, a lab coat, and chemical-resistant gloves.[1] Handle in a well-ventilated area and avoid creating dust.[1]

Q3: Is **4-fluoro-L-phenylalanine** sensitive to light?

A3: Yes, it may be sensitive to light exposure.[5] It is best practice to store it in a light-protected container.

Solution Preparation

Q4: What solvents can be used to dissolve **4-fluoro-L-phenylalanine**?

A4: **4-fluoro-L-phenylalanine** is soluble in water and 0.5M HCl at a concentration of 50 mg/ml.[3][6] It is also soluble in PBS (pH 7.2) at 5 mg/ml and in DMSO at 55 mg/mL.[4][7] For stock solutions, using water or a buffer appropriate for your experiment is recommended. If using water, it may be necessary to warm the solution and sonicate to fully dissolve the compound.[9]

Q5: How should I prepare a sterile stock solution for cell culture experiments?

A5: To prepare a sterile stock solution, dissolve the **4-fluoro-L-phenylalanine** in your desired solvent (e.g., water or PBS) and then sterilize it by passing it through a 0.22 µm filter.[9]

Experimental Use

Q6: What is the primary application of **4-fluoro-L-phenylalanine** in research?

A6: **4-fluoro-L-phenylalanine** is widely used as a non-canonical amino acid for incorporation into proteins.[2] The fluorine atom serves as a sensitive probe for ¹⁹F Nuclear Magnetic Resonance (NMR) spectroscopy, which can be used to study protein structure, dynamics, and interactions.[10][11] It is also used in drug design and protein engineering to enhance protein stability and binding affinities.[2]

Q7: Can **4-fluoro-L-phenylalanine** be incorporated into proteins in both bacterial and mammalian cells?

A7: Yes, there are established protocols for the successful incorporation of **4-fluoro-L-phenylalanine** into proteins in both E. coli and mammalian cell lines like HEK293T.[10]

Troubleshooting Guides

Low Incorporation Efficiency

Q1: I am observing low or no incorporation of **4-fluoro-L-phenylalanine** into my protein of interest. What are the possible causes and solutions?

A1: Low incorporation efficiency is a common issue. Here are several factors to consider:

- **Cell Health:** Ensure your cells are healthy and in the logarithmic growth phase, as protein synthesis is linked to cell viability.[12]
- **Suboptimal Labeling Conditions:** The concentration of the labeled amino acid and the duration of labeling are critical. It is essential to use a medium deficient in natural phenylalanine to maximize the uptake of **4-fluoro-L-phenylalanine**. [10][12]
- **Toxicity:** High concentrations of **4-fluoro-L-phenylalanine** can be toxic to cells, leading to decreased protein expression. It is important to determine the optimal concentration for your specific cell line and protein.
- **Incomplete Phenylalanine Depletion:** If using a medium-switch protocol, ensure that the standard, phenylalanine-containing medium is completely removed before adding the labeling medium.

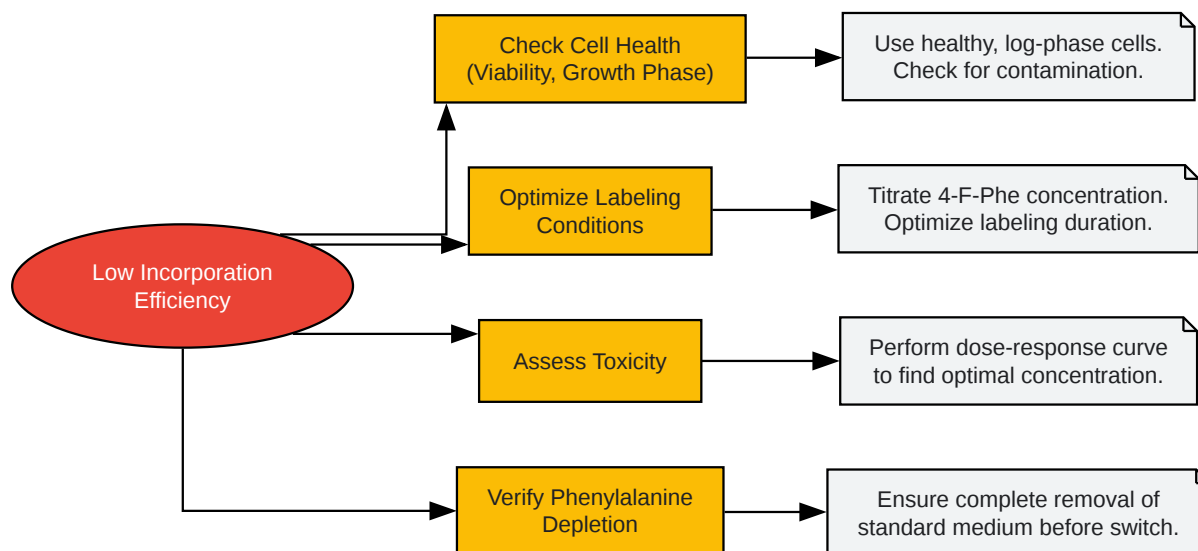

[Click to download full resolution via product page](#)

Troubleshooting low incorporation efficiency.

Protein Expression and Purity Issues

Q2: My protein yield is significantly lower when I incorporate **4-fluoro-L-phenylalanine**. What can I do?

A2: The introduction of a non-canonical amino acid can sometimes impact protein yield.[10] Consider reducing the expression temperature (e.g., 18-25°C) and extending the expression time.[10] Also, ensure that the concentration of **4-fluoro-L-phenylalanine** is not excessively high, as this can inhibit protein synthesis.[4]

Q3: I am seeing signs of protein misfolding or aggregation. Could this be related to the incorporation of **4-fluoro-L-phenylalanine**?

A3: While **4-fluoro-L-phenylalanine** is structurally similar to phenylalanine, its incorporation can sometimes perturb protein structure and stability.[11] If you suspect misfolding, consider co-expressing chaperones or using a different expression host. Analyzing the protein's thermal stability (e.g., via differential scanning fluorimetry) can help quantify the impact of the incorporation.

Analytical Issues

Q4: My ^{19}F NMR spectrum shows multiple peaks or broad signals. What could be the cause?

A4: Multiple or broad peaks in the ^{19}F NMR spectrum can indicate conformational heterogeneity in the protein.^[13] This means that the local environment around the incorporated **4-fluoro-L-phenylalanine** residues may exist in multiple states. Temperature studies can help determine if these states are in slow or fast exchange.^[13] It is also crucial to ensure the protein sample is pure and properly folded.

Experimental Protocols

Protocol 1: Incorporation of 4-fluoro-L-phenylalanine in *E. coli*

This protocol is adapted from established methods for labeling proteins with fluorinated amino acids.^{[10][14]}

- Transform the expression plasmid into a suitable *E. coli* strain (e.g., BL21(DE3)).
- Inoculate a single colony into a starter culture of LB medium with the appropriate antibiotic and grow overnight at 37°C.
- Inoculate a larger volume of M9 minimal medium with the starter culture and grow at 37°C to an OD₆₀₀ of 0.6-0.8.
- Pellet the cells by centrifugation and wash with M9 medium lacking phenylalanine.
- Resuspend the cells in M9 medium supplemented with **4-fluoro-L-phenylalanine** (e.g., 50-100 mg/L) and all other essential amino acids.
- Induce protein expression with an appropriate concentration of IPTG (e.g., 0.1-1 mM).
- Reduce the temperature to 18-25°C and continue to express the protein overnight.
- Harvest the cells by centrifugation and store the pellet at -80°C until purification.

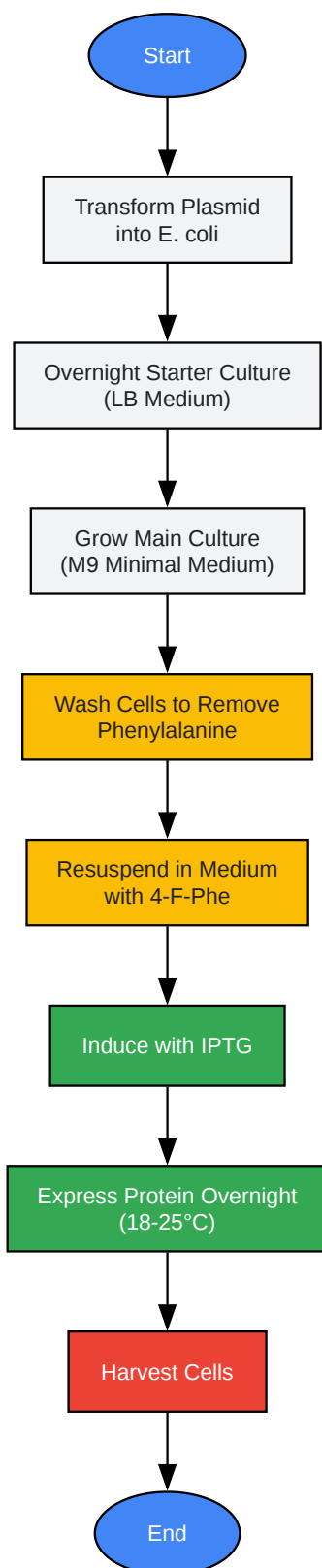

[Click to download full resolution via product page](#)

Workflow for incorporating 4-F-Phe in E. coli.

Protocol 2: Incorporation of 4-fluoro-L-phenylalanine in Mammalian Cells (HEK293T)

This protocol is based on a medium-switch strategy.^{[10][15]}

- Culture HEK293T cells in standard DMEM.
- Transfect the cells with the expression plasmid using a suitable transfection reagent.
- After 24 hours of initial expression, replace the standard medium with a custom medium that lacks phenylalanine but is supplemented with **4-fluoro-L-phenylalanine**.
- Incubate the cells for an additional 24-48 hours to allow for expression and incorporation of the fluorinated analog.
- Harvest the cells for analysis or protein purification.

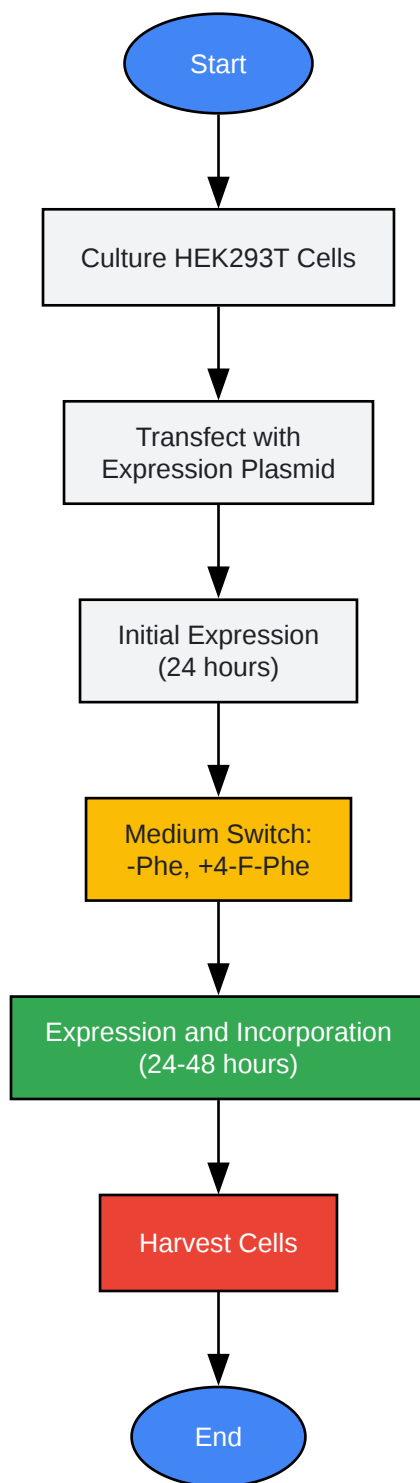

[Click to download full resolution via product page](#)

Workflow for incorporating 4-F-Phe in mammalian cells.

Need Custom Synthesis?

BenchChem offers custom synthesis for rare earth carbides and specific isotopic labeling.

Email: info@benchchem.com or [Request Quote Online](#).

References

- 1. fishersci.com [fishersci.com]
- 2. chemimpex.com [chemimpex.com]
- 3. L-4-Fluorophenylalanine | 1132-68-9 [chemicalbook.com]
- 4. caymanchem.com [caymanchem.com]
- 5. 4-FLUORO-D,L-PHENYLALANINE | CAMEO Chemicals | NOAA [cameochemicals.noaa.gov]
- 6. 4-Fluoro-L-phenylalanine, 98+% 250 mg | Buy Online | Thermo Scientific Chemicals | Fisher Scientific [fishersci.com]
- 7. 4-Fluoro-D-phenylalanine HCl | TargetMol [targetmol.com]
- 8. 4-Fluoro-L-phenylalanine- HCl (ring-4- C^{13} , 98%; 3,5- D_2 , 98%) CP 95% | Cambridge Isotope Laboratories, Inc. [isotope.com]
- 9. medchemexpress.com [medchemexpress.com]
- 10. benchchem.com [benchchem.com]
- 11. Fluorinated phenylalanines: synthesis and pharmaceutical applications - PMC [pmc.ncbi.nlm.nih.gov]
- 12. benchchem.com [benchchem.com]
- 13. pubs.acs.org [pubs.acs.org]
- 14. benchchem.com [benchchem.com]
- 15. Controlling the incorporation of fluorinated amino acids in human cells and its structural impact - PMC [pmc.ncbi.nlm.nih.gov]
- To cite this document: BenchChem. [Best practices for handling and storing 4-fluoro-L-phenylalanine]. BenchChem, [2025]. [Online PDF]. Available at: [https://www.benchchem.com/product/b556548#best-practices-for-handling-and-storing-4-fluoro-l-phenylalanine]

Disclaimer & Data Validity:

The information provided in this document is for Research Use Only (RUO) and is strictly not intended for diagnostic or therapeutic procedures. While BenchChem strives to provide accurate protocols, we make no warranties, express or implied, regarding the fitness of this product for every specific experimental setup.

Technical Support: The protocols provided are for reference purposes. Unsure if this reagent suits your experiment? [[Contact our Ph.D. Support Team for a compatibility check](#)]

Need Industrial/Bulk Grade? [Request Custom Synthesis Quote](#)

BenchChem

Our mission is to be the trusted global source of essential and advanced chemicals, empowering scientists and researchers to drive progress in science and industry.

Contact

Address: 3281 E Guasti Rd
Ontario, CA 91761, United States
Phone: (601) 213-4426
Email: info@benchchem.com