

Application Note: Structural Elucidation of N-Acetyl-L-prolinamide using NMR Spectroscopy

Author: BenchChem Technical Support Team. **Date:** May 2026

Compound of Interest

Compound Name: *N-Acetyl-L-prolinamide*

CAS No.: 16395-58-7

Cat. No.: B556383

[Get Quote](#)

Audience: Researchers, scientists, and drug development professionals.

Introduction: **N-Acetyl-L-prolinamide** is a derivative of the amino acid L-proline, featuring an acetyl group on the nitrogen atom and a primary amide at the carboxyl end. Its structural confirmation is critical in synthetic chemistry and drug discovery processes where proline scaffolds are common. Nuclear Magnetic Resonance (NMR) spectroscopy is the most powerful technique for the unambiguous structural elucidation of such molecules in solution. This document provides a detailed protocol for the analysis of **N-Acetyl-L-prolinamide** using one-dimensional (^1H , ^{13}C) and two-dimensional (COSY, HSQC) NMR experiments.

Molecular Structure and Atom Numbering

The structure of **N-Acetyl-L-prolinamide** with standardized atom numbering for NMR assignment is presented below. The presence of the acetyl group introduces cis-trans isomerism about the acetyl-proline amide bond, which results in two distinct sets of signals in the NMR spectra.[1][2]

Caption: Molecular structure of **N-Acetyl-L-prolinamide** with atom numbering.

Experimental Protocols

Sample Preparation

A well-prepared sample is crucial for acquiring high-quality NMR spectra. The sample should be free of particulate matter and paramagnetic impurities.

- Weighing: Accurately weigh 5-25 mg of **N-Acetyl-L-prolinamide** for ^1H NMR and 50-100 mg for ^{13}C NMR into a clean, dry vial.[3]
- Solvent Selection: Choose a suitable deuterated solvent in which the compound is soluble (e.g., D_2O , CDCl_3 , DMSO-d_6). Deuterated solvents are essential to avoid large solvent signals in the ^1H spectrum and for the instrument's lock system.[1]
- Dissolution: Add approximately 0.6-0.7 mL of the chosen deuterated solvent to the vial.[3] Vortex or gently warm the mixture if necessary to ensure complete dissolution.
- Filtration and Transfer: To remove any insoluble impurities, filter the solution through a small plug of cotton or glass wool packed into a Pasteur pipette directly into a clean, dry 5 mm NMR tube.[4]
- Capping and Labeling: Securely cap the NMR tube and label it clearly with the sample identification.

NMR Data Acquisition Workflow

The structural elucidation follows a logical workflow from simple 1D experiments to more complex 2D correlation experiments.

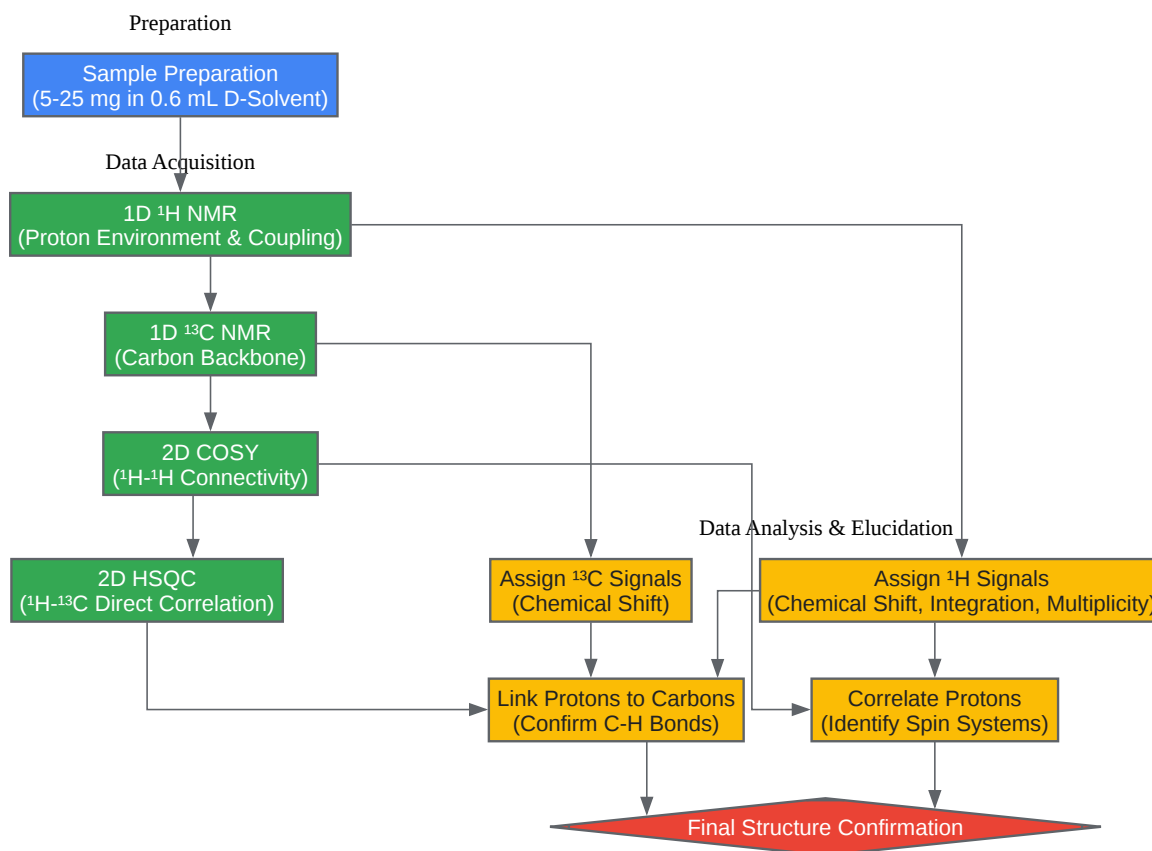

[Click to download full resolution via product page](#)

Caption: Experimental workflow for NMR-based structural elucidation.

Data Analysis and Interpretation

¹H NMR Spectroscopy

The ¹H NMR spectrum provides information about the number of different types of protons, their electronic environment, and their connectivity to neighboring protons. Due to restricted rotation around the N-acetyl bond, **N-Acetyl-L-prolinamide** exists as a mixture of cis and trans isomers, leading to a duplication of proton signals.[1][2] The following table summarizes the reported ¹H NMR data in D₂O.

Table 1: ¹H NMR Data for **N-Acetyl-L-prolinamide** in D₂O[1][2]

Atom	Chemical Shift δ (ppm) - trans	Chemical Shift δ (ppm) - cis	Multiplicity
H α (2)	4.49	4.67	dd
H β , H β' (3)	2.00 - 2.40	2.00 - 2.40	m
H γ , H γ' (4)	1.85 - 2.10	1.85 - 2.10	m
H δ , H δ' (5)	3.60 - 3.80	3.60 - 3.80	m
CH ₃ (8)	2.12	2.07	s
NH ₂ (9)	~7.0 - 7.5	~7.0 - 7.5	br s (each)

Note: The signals for the pyrrolidine ring protons (β , γ , δ) are complex multiplets and often overlap. The amide (NH₂) protons are visible as two broad singlets and their chemical shift is highly dependent on solvent and concentration.

¹³C NMR Spectroscopy

The ¹³C NMR spectrum reveals the carbon framework of the molecule. Each unique carbon atom gives a distinct signal. The data below is predicted based on typical chemical shifts for amides and related proline derivatives.[5][6][7]

Table 2: Predicted ¹³C NMR Data for **N-Acetyl-L-prolinamide**

Atom	Predicted Chemical Shift δ (ppm)
Cα (2)	59 - 62
C β (3)	29 - 32
C γ (4)	24 - 27
C δ (5)	46 - 49
C' (6)	172 - 175
CH ₃ (8)	21 - 24
C(O)NH ₂ (9)	175 - 178

Note: Two distinct signals for each carbon may be observed due to the presence of cis and trans isomers.

2D NMR: COSY and HSQC

Two-dimensional NMR experiments are essential for unambiguously assigning the complex signals of the pyrrolidine ring.

- COSY (Correlation Spectroscopy): This experiment identifies protons that are coupled to each other (typically through 2-3 bonds). Cross-peaks in the COSY spectrum connect coupled protons. This is invaluable for tracing the connectivity from H α through H β , H γ , and H δ protons within the ring.



[Click to download full resolution via product page](#)

Caption: Expected ¹H-¹H COSY correlations in the pyrrolidine ring.

- HSQC (Heteronuclear Single Quantum Coherence): The HSQC experiment correlates protons directly to their attached carbons. Each cross-peak in the HSQC spectrum

represents a C-H bond, providing a direct link between the ^1H and ^{13}C assignments. This allows for the definitive assignment of each carbon in the pyrrolidine ring ($\text{C}\alpha$, $\text{C}\beta$, $\text{C}\gamma$, $\text{C}\delta$) and the acetyl methyl group ($\text{C}\delta$).

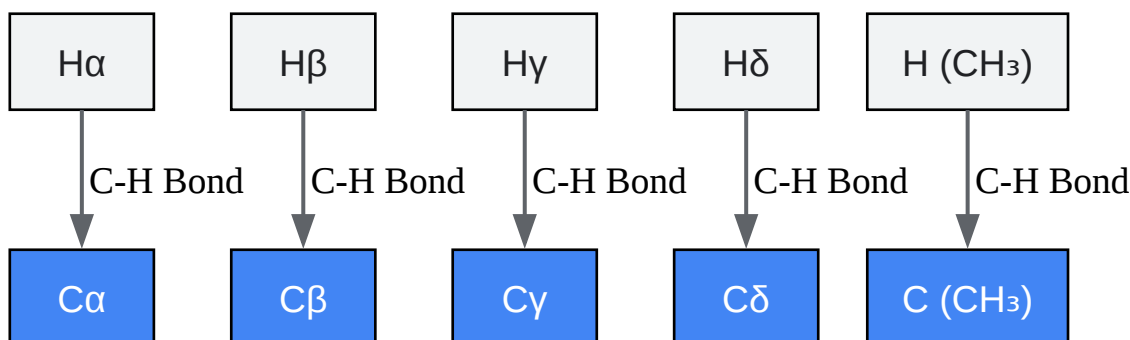

[Click to download full resolution via product page](#)

Caption: Expected ^1H - ^{13}C HSQC correlations for **N-Acetyl-L-prolinamide**.

Summary

The combination of 1D and 2D NMR techniques provides a comprehensive method for the structural elucidation of **N-Acetyl-L-prolinamide**. ^1H NMR identifies all proton environments and reveals the presence of cis/trans isomers.[1][2] ^{13}C NMR details the carbon skeleton. Finally, 2D COSY and HSQC experiments establish the critical H-H and C-H connectivities, respectively, allowing for the complete and unambiguous assignment of the molecular structure. This protocol serves as a standard workflow for the analysis of proline derivatives and other small molecules in a research and development setting.

Need Custom Synthesis?

BenchChem offers custom synthesis for rare earth carbides and specific isotopic labeling.

Email: info@benchchem.com or [Request Quote Online](#).

References

- 1. NMR investigations of proline and its derivatives. 4-Proton magnetic resonance parameters and structure of acetyl-proline amide - PubMed [pubmed.ncbi.nlm.nih.gov]

- [2. NMR investigations of proline and its derivatives. 4-Proton magnetic resonance parameters and structure of acetyl-proline amide. | Semantic Scholar \[semanticscholar.org\]](#)
- [3. mr.copernicus.org \[mr.copernicus.org\]](#)
- [4. scs.illinois.edu \[scs.illinois.edu\]](#)
- [5. pure.kfupm.edu.sa \[pure.kfupm.edu.sa\]](#)
- [6. Human Metabolome Database: Showing metabocard for N-Acetylproline \(HMDB0094701\) \[hmdb.ca\]](#)
- [7. ucl.ac.uk \[ucl.ac.uk\]](#)
- [To cite this document: BenchChem. \[Application Note: Structural Elucidation of N-Acetyl-L-prolinamide using NMR Spectroscopy\]. BenchChem, \[2026\]. \[Online PDF\]. Available at: \[https://www.benchchem.com/product/b556383/docs#application-note-structural-elucidation-of-n-acetyl-l-prolinamide-using-nmr-spectroscopy\]](#)

Disclaimer & Data Validity:

The information provided in this document is for Research Use Only (RUO) and is strictly not intended for diagnostic or therapeutic procedures. While BenchChem strives to provide accurate protocols, we make no warranties, express or implied, regarding the fitness of this product for every specific experimental setup.

Technical Support: The protocols provided are for reference purposes. Unsure if this reagent suits your experiment?

Need Industrial/Bulk Grade? [Request Custom Synthesis Quote](#)

BenchChem

Our mission is to be the trusted global source of essential and advanced chemicals, empowering scientists and researchers to drive progress in science and industry.

Contact

Address: 3281 E Guasti Rd
Ontario, CA 91761, United States
Phone: (601) 213-4426
Email: info@benchchem.com

Contact our Ph.D. Support Team for a compatibility check